

Chapter-2

SETS

In Mathematics, Set theory was developed by **George Cantor** (1845 – 1918).

Set: A well defined collections of objects is called a **Set**.

Well defined means that

- (i) All the objects in the Set should have a common feature or property and
- (ii) It should be possible to decide whether any given objects belongs to the set or not.

We usually denote a set by capital letters and the elements of a set are represented by small letters.

Ex: Set of vowels in English language $V = \{ a, e, i, o, u \}$

Set of even numbers $E = \{ 2, 4, 6, 8, \dots \}$

Set of odd numbers $O = \{ 1, 3, 5, 7, \dots \}$

Set of prime numbers $P = \{ 2, 3, 5, 7, 11, 13, \dots \}$

Any element or object belonging to a set, then we use symbol ' \in ' (belongs to), if it is not belonging to it is denoted by the Symbol ' \notin ' (does not belongs to)

Ex: In Natural numbers Set N , $1 \in N$ and $0 \notin N$

Roaster Form: All elements are written in order by separating commas and are enclosed with in curly brackets is called Roaster form. In the form elements should not repeated.

Ex: Set of prime numbers less than 13 is $p = \{ 2, 3, 5, 7, 11 \}$

Set Builder Form: In set builder form, we use a symbol x (or any other symbol y, z etc.) for the element of the set. This is following by a colon (or a vertical line), after which we write the characteristic property possessed within curly brackets.

Ex: $P = \{ 2, 3, 5, 7, 11 \}$. This is the set of all prime numbers less than 13. It can be represented in the set builders form as

$$P = \{ x: x \text{ is a prime numbers less than } 13 \}$$

(Or)

$$P = \{ x/x \text{ is a prime number less than } 13 \}$$

Null Set: A set which does not contain any element is called the empty set or the null get or a void set .It is denoted by ϕ or $\{ \}$

Ex: $A = \{ x/ 1 < x < 2, x \text{ is a natural numbers} \}$

$$B = \{ x/ x^2 - 2 = 0 \text{ and } x \text{ is a rational number} \}$$

Finite Set: A set is called a finite set if it is possible to count the numbers of elements in it.

Ex: $A = \{ x ; x \in \mathbb{N} \text{ and } (x-1)(x-2) = 0 \} = \{ 1, 2 \}$

$$B = \{ x; x \text{ is a day in a week} \} = \{ \text{SUN, MON, TUS, WED, THU, FRI, SAT} \}$$

Infinite Set: A Set is called an infinite set if the number of cannot count the number of elements in it.

Ex: $A = \{ x / x \in \mathbb{N} \text{ and } x \text{ is an odd number} \}$

$$= \{ 1, 3, 5, 7, 9, 11, \dots \}$$

$$B = \{ x/ x \text{ is a point on a straight line} \}$$

Cardinal Number: The number of elements in a Set is called the cardinal number of the set. If 'A' is a set then $n(A)$ represents cardinal number.

Ex: If $A = \{ a, e, i, o, u \}$ then $n(A) = 5$

If $B = \{x; x \text{ is alter in the word INDIA}\}$

Then $n(B) = 4$

$N(\phi) = 0$

Universal Set: Universal Set is denoted by ' μ ' or ' U ' generally, universal set represented by rectangle.

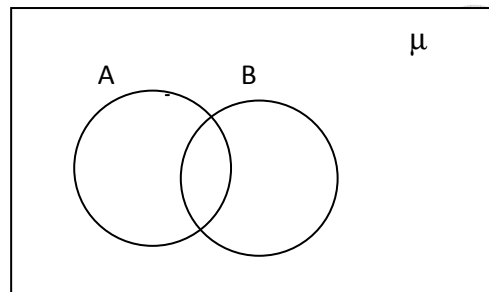

Subset: If every element of a set A is also an element of set B, then the set A is said to be a subset of set B. It is represented as $A \subset B$.

Ex: If $A = \{4, 8, 12\}$; $B = \{2, 4, 6, 8, 10, 12, 14\}$ then

A is a subset of B (i.e. $A \subset B$)

- Every Set is a subset of itself ($A \subset A$)
- Empty Set is a subset of every set ($\phi \subset A$)
- If $A \subset B$ and $B \subset C$ then $A \subset C$ (Transitive property)

Equal Sets: Two sets A and B are said to be 'equal' if every elements in A belongs to B and every elements in B belongs to A. If A and B are equal sets, then we write $A = B$.

Ex: The set of prime number less than 6, $A = \{2, 3, 5\}$

The prime factors of 30, $B = \{2, 3, 5\}$

Since the elements of A are the same as the elements of B, therefore, A and B are equal.

- $A \subset B$ and $B \subset A \Leftrightarrow A = B$ (Ant symmetric property)

Venn Diagrams: Venn-Euler diagram or Simply Venn diagram is a way of representing the relationships between sets. These diagrams consist of rectangles and closed curves usually circles.

Ex:

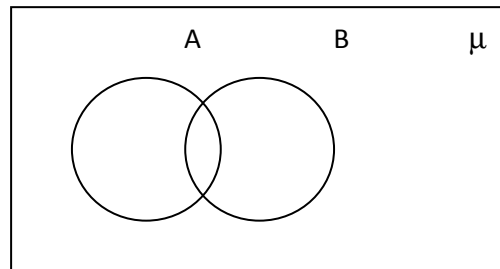

Basic operations on Sets: We know that arithmetic has operation of addition, subtraction and multiplication of numbers. Similarly in Sets, we define the operation of Union, Intersection and difference of Sets.

Union of Sets: The union of A and B is the Set which contains all the elements of A and also the elements of B and the common element being taken only once. The symbol 'U' is used to denote the union. Symbolically, we write $A \cup B$ and read as 'A' union 'B'.

$$A \cup B = \{x/x \in A \text{ or } x \in B\}$$

Ex: $A = \{1, 2, 3, 4, 5\}$: $B = \{2, 4, 6, 8, 10\}$

Then $A \cup B = \{1, 2, 3, 4, 5, 6, 8, 10\}$

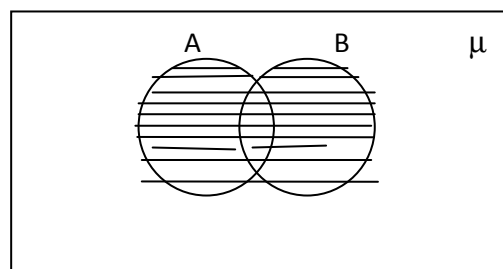

- $A \cup B = A$
- $A \cup \phi = A = \phi \cup A$ (identity property)
- $A \cup \mu = \mu = \mu \cup A$
- If $A \subset B$ then $A \cup B = B$
- $A \cup B = B \cup A$ (Commutative property)

Intersection of Sets: The intersection of A and B is the Set in which the elements that are common to both A and B. The Symbol ' \cap ' is used to denote the 'intersection'.

Symbolically we " $A \cap B$ " and read as "A intersection B".

$$A \cap B = \{ x / x \in A \text{ and } x \in B \}$$

Ex: $A = \{ 1, 2, 3, 4, 5 \}$ and $B = \{ 2, 4, 6, 8, 10 \}$

Then $A \cap B = \{ 2, 4 \}$

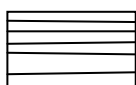
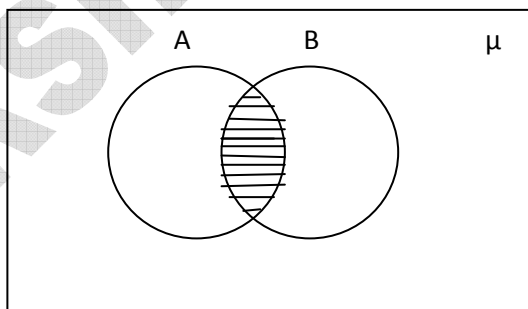

Represents $A \cap B$

- $A \cap B = A$
- $A \cap \phi = \phi = \phi \cap A$
- $A \cap \mu = A = \mu \cap A$ (identity property)
- If $A \subset B$ then $A \cap B = A$
- $A \cap B = B \cap A$ (Commutative property)

Disjoint Sets: If there are no common elements in A and B. Then the Sets are Known as disjoint sets.

If A, B are disjoint sets then $A \cap B = \phi$

If $A \cap B = \phi$ then $n(A \cap B) = 0$

Ex: $A = \{ 1, 3, 5, 7, \dots \}$: $B = \{ 2, 4, 6, 8, \dots \}$

Here A and B have no common elements

\therefore A and B are called disjoint Sets.

i.e. $A \cap B = \phi$

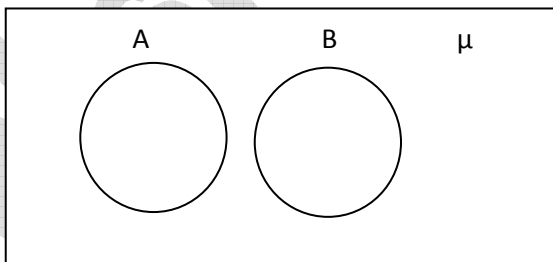

Difference of Sets: The difference of Sets A and B is the set of elements which belongs to A but do not belong to B. We denote the difference of A and B by $A - B$ or simply “A minus B”

$$A - B = \{ x / x \in A \text{ and } x \notin B \}$$

$$B - A = \{ x / x \in B \text{ and } x \notin A \}$$

Ex: If $A = \{ 1, 2, 3, 4, 5 \}$ and $B = \{ 4, 5, 6, 7 \}$ then

$$A - B = \{ 1, 2, 3 \}, \quad B - A = \{ 6, 7 \}$$

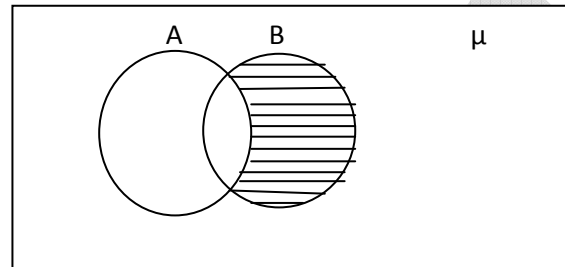
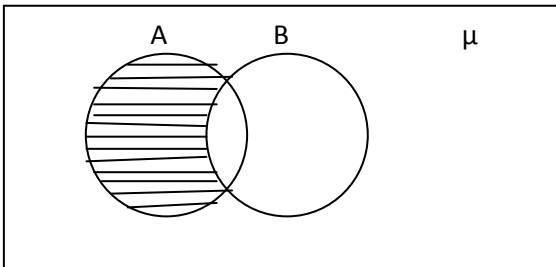

 represents 'A - B'

 represents B - A

- $A - B \neq B - A$
- $A - B$, $B - A$ and $A \cap B$ are disjoint Sets.
- $n(A \cup B) = n(A) + n(B) - n(A \cap B)$
- If A, B are disjoint sets then $n(A \cup B) = n(A) + n(B)$

Essay type Questions

(1) Write the following sets in roster form. (Communication)

- (i) $A = \{ x : x \text{ is a two digital natural number such that the sum of its digits is } 8 \}$
- (ii) $B = \{ x : x \text{ is a natural number and } x^2 < 40 \}$
- (iii) $C = \{ x : x \text{ is a prime number which is a divisor of } 60 \}$
- (iv) $D = \{ x : x \text{ is an integers , } x^2 = 4 \}$

Solution:

Set builder form:

- (i). $A = \{ x : x \text{ is a two digital natural number such that the sum of its digits is } 8 \}$

Roster form:

$$A = \{ 17, 26, 35, 44, 53, 62, 71, 80 \}$$

- (ii). Set builder form:

$$B = \{ x : x \text{ is a natural number and } x^2 < 40 \}$$

Roster form:

$$B = \{ 1, 2, 3, 4, 5, 6 \}$$

- (iii). Set builder form:

$$C = \{ x : x \text{ is a prime number which is a divisor of } 60 \}$$

Roster form:

$$C = \{ 2, 3, 5 \}$$

- (iv). Set builder form:

$$D = \{ x : x \text{ is an integers , } x^2 = 4 \}$$

Roster form:

$$D = \{ -2, 2 \}$$

(2). Write the following sets in the sets -builders form. (Communication)

(i) $A = \{1, 2, 3, 4, 5\}$

(ii) $B = \{5, 25, 125, 625\}$

(iii) $C = \{1, 2, 3, 6, 7, 14, 21, 42\}$

(iv) $D = \{1, 4, 9, \dots, 100\}$

Solution:

(i). Roster form:

$$A = \{1, 2, 3, 4, 5\}$$

Set builder form

$$A = \{x : x \text{ is a natural number } x < 6\}$$

(ii). Roster form:

$$B = \{5, 25, 125, 625\}$$

Set builder form:

$$B = \{x : x \text{ is a natural number and power of } 5, x < 5\}$$

(Or)

$$B = \{5^x : x \in \mathbb{N}, x \leq 4\}$$

(iii). Roster form:

$$C = \{1, 2, 3, 6, 7, 14, 21, 42\}$$

Set builder form:

$$C = \{x : x \text{ is a natural number which divides } 42\}$$

(iv). Roster form:

$$D = \{ 1, 4, 9, \dots, 100 \}$$

Set builder form:

$$D = \{ x : x \text{ in Square of natural number and not greater than } 10 \}$$

(or)

$$= \{ x^2 : x \in \mathbb{N}, x \leq 10 \}$$

(3). State which of the following Sets are finite or infinite. (Reasoning proof)

(i). $\{x: x \in \mathbb{N} \text{ and } (x-1)(x-2) = 0\}$

(ii). $\{x: x \in \mathbb{N} \text{ and } x < 100\}$

(iii). $\{x: x \text{ is a straight line which is parallel to X - Axis}\}$

(iv). **The Set of circles passing through the origin (0 ,0)**

Solution:

(i). $\{x: x \in \mathbb{N} \text{ and } (x-1)(x-2) = 0\}$

x can take the values 1 or 2 in the given case . The set is $\{ 1, 2 \}$, Hence it is finite.

(ii). $\{x: x \in \mathbb{N} \text{ and } x < 100\}$

$= \{ 1, 2, \dots, 100\}$, The number of elements in this Set are countable . Hence it is finite.

(iii). { x: x is a straight line which is parallel to X – Axis }

Infinite straight lines are parallel to X – axis

Hence, it is infinite Set

(iv). The Set of circles passing through the origin (0 ,0)

Infinite circles are passing through the origin (0, 0)

Hence it is infinite Set

(4) . Let $A = \{3, 4, 5, 6, 7\}$, and $B = \{1, 6, 7, 8, 9\}$ Find

(i) . $A \cup B$ (ii) $A \cap B$ (iii) $A - B$ (iv) $B - A$ (Problem Solving)

Solution: Given $A = \{3, 4, 5, 6, 7\}$, $B = \{1, 6, 7, 8, 9\}$

(i) $A \cup B = \{ 3, 4, 5, 6, 7, 8, 8 \}$

(ii) $A \cap B = \{ 6, 7 \}$

(iii) $A - B = \{ 3, 4, 5 \}$

(iv) $B - A = \{1, 8, 9 \}$

(5). (i) Illustrate $A \cup B$ in Venn – diagrams where

$$A = \{ 1, 2, 3, 4 \} \text{ and } B = \{ 2, 4, 6, 8 \}$$

(ii) Illustrate in the Venn –diagrams where

$$A = \{ 1, 2, 3 \} \text{ and } B = \{ 3, 4, 5 \} \quad (\text{visualization \& representation})$$

Solution: (i) $A = \{ 1, 2, 3, 4 \}$

$$B = \{ 2, 4, 6, 8 \}$$

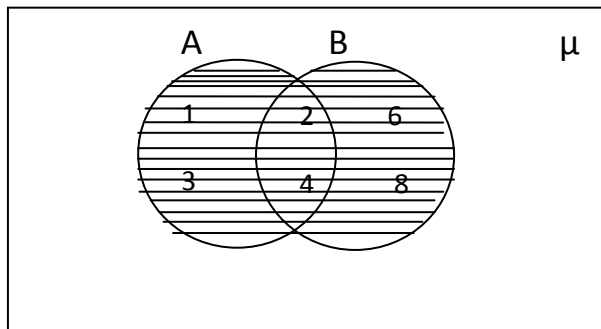

$$A \cup B = \{ 1, 2, 3, 4, 6, 8 \}$$

(iii) $A = \{ 1, 2, 3 \}$

$$B = \{ 3, 4, 5 \}$$

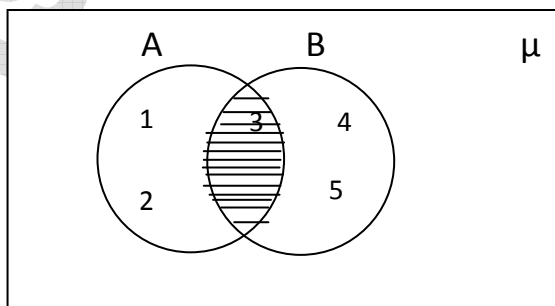

$$A \cap B = \{ 3 \}$$

(6). If $A = \{ 3, 4, 5, 6, 7 \}$, $B = \{ 1, 6, 7, 8, 9 \}$ then find $n(A)$, $n(B)$, $n(A \cap B)$ and $n(A \cup B)$. What do you observe ? (Reasoning Proof)

Solution:

$$A = \{ 3, 4, 5, 6, 7 \} , \quad n(A) = 5$$

$$B = \{ 1, 6, 7, 8, 9 \} \quad n(B) = 5$$

$$A \cup B = \{ 1, 3, 4, 5, 6, 7, 8, 9 \} \quad n(A \cup B) = 8$$

$$A \cap B = \{ 6, 7 \} \quad n(A \cap B) = 2$$

We observe that $n(A \cup B) = n(A) + n(B) - n(A \cap B)$

(Or)

$$n(A \cap B) = n(A) + n(B) - n(A \cup B)$$

(Or)

$$n(A \cup B) + n(A \cap B) = n(A) + n(B)$$

(7). If $A = \{ x: x \text{ is a natural number} \}$

$B = \{ x: x \text{ is an even natural number} \}$

$C = \{ x: x \text{ is an odd natural number} \}$

$D = \{ x: x \text{ is a prime number} \}$ Find $A \cap B$, $A \cap C$, $A \cap D$, $B \cap C$,

$B \cap D$, $C \cap D$ (Problem solving)

Solution: $A = \{ x: x \text{ is a natural number} \}$

$$= \{ 1, 2, 3, 4, \dots \}$$

$$B = \{ x: x \text{ is a even natural number } \}$$

$$= \{ 2, 4, 6, \dots \}$$

$$C = \{ x: x \text{ is a odd natural number } \}$$

$$= \{ 1, 3, 5, 7, \dots \}$$

$$D = \{ x: x \text{ is a prime number } \}$$

$$= \{ 2, 3, 5, 7, 11, 13, \dots \}$$

$$A \cap B = \{ 1, 2, 3, 4, \dots \} \cap \{ 2, 4, 6, \dots \} = \{ 2, 4, 6, \dots \} = B$$

$$A \cap C = \{ 1, 2, 3, 4, \dots \} \cap \{ 1, 3, 5, 7, \dots \} = \{ 1, 3, 5, 7, \dots \} = C$$

$$A \cap D = \{ 1, 2, 3, 4, \dots \} \cap \{ 2, 3, 5, 7, 11, 13, \dots \} = \{ 2, 3, 5, 7, \dots \} = D$$

$$B \cap C = \{ 2, 4, 6, \dots \} \cap \{ 1, 3, 5, 7, \dots \} = \{ \} = \phi$$

B and C are disjoint Sets

$$B \cap D = \{ 2, 4, 6, \dots \} \cap \{ 2, 3, 5, 7, 11, 13, \dots \} = \{ 2 \}$$

$$C \cap D = \{ 1, 3, 5, 7, \dots \} \cap \{ 2, 3, 5, 11, 13, \dots \} = \{ 3, 5, 7, 11, 13, \dots \}$$

(8) . Using examples to show that $A - B$, $B - A$ and $A \cap B$ are mutually disjoint Sets .

(Reasoning proof)

Solution:

$$\text{Let } A = \{ 1, 2, 3, 4, 5 \} , \quad B = \{ 4, 5, 6, 7 \}$$

$$A \cap B = \{ 4, 5 \}$$

$$A - B = \{ 1, 2, 3 \}$$

$$B - A = \{ 6, 7 \}$$

We observe that the Sets $A \cap B$, $A - B$, $B - A$ are mutually disjoint Sets.

Short Answer Questions

(1) Match roster forms with the Set builder form. (Connection)

- | | |
|---------------------------|---|
| (1) { 2, 3 } | (a) { x: x is a positive integer and is a divisor of 18 } |
| (2) { 0 } | (b) { x: x is an integer and $x^2 - 9 = 0$ } |
| (3) { 1, 2, 3, 6, 9, 18 } | (c) { x: x is an integer and $x+1 = 1$ } |
| (4) { 3, -3 } | (d) { x: x is prime number and advisor of 6 } |

Answers: (1) d (2) c (3) a (4) b

(2) State which of the following Sets are empty and which are not ? (Reasoning proof)

- (i) $A = \{ x: x^2 = 4 \text{ and } 3x = 9 \}$
- (ii) Sets of even prime numbers
- (iii) $B = \{ x: x^2 - 2 = 0 \text{ and } x \text{ is a rational number} \}$
- (iv) Set of odd numbers divisible by 2

Solution:

(i) $A = \{ x: x^2 = 4 \text{ and } 3x = 9 \}$

Solution of $x^2 = 4$ are $x = \pm 2$ and $3x = 9$ is $x = 3$

There is no real number satisfies both equation $x^2 = 4$ and $3x = 4$

$\therefore A = \{ x: x^2 = 4 \text{ and } 3x = 9 \}$ is an empty Set.

(ii) Sets of even prime numbers

2 is a only even prime number

\therefore Hence given Set is not empty set.

(iii). $B = \{ x: x^2 - 2 = 0 \text{ and } x \text{ is a rational number} \}$

The solution of $x^2 - 2 = 0$ is $x = \pm \sqrt{2}$, but

$-\sqrt{2}, \sqrt{2}$ are not rational numbers.

$\therefore B = \{ x: x^2 - 2 = 0 \text{ and } x \text{ is a rational number} \}$ is an empty set.

(iv). Set of odd numbers divisible by 2

Set of odd number = $\{ 1, 3, 5, 7, \dots \}$

Odd number are not divisible by 2

\therefore Given Set is an empty Set.

(3) Let A be the Set of prime numbers less than 6 and P the Set of prime factors of 30. Check if A and P are equal. (Reasoning Proof)

Solution: The Set of Prime number less than 6, $A = \{ 2, 3, 5 \}$

The Prime factors of 30, $P = \{ 2, 3, 5 \}$

Since the element of A are the same as the elements of P, \therefore A and P are equal.

(4) List all the subsets of the Set $A = \{ 1, 4, 9, 16 \}$ (Communication)

Solution: We know that empty set (ϕ) and itself (A) are the subsets of every set.

\therefore All the subsets of the set $A = \{ 1, 4, 9, 16 \}$

Are $\phi, \{ 1 \}, \{ 4 \}, \{ 9 \}, \{ 16 \}$

$\{ 1, 4 \}, \{ 1, 9 \}, \{ 1, 16 \}, \{ 4, 9 \}, \{ 4, 16 \}, \{ 9, 16 \}$

$\{1, 4, 9\}, \{1, 4, 16\}, \{1, 9, 16\}, \{4, 9, 16\}$ and $\{1, 4, 9, 16\}$

Total number of subsets of the set $A = \{1, 4, 9, 16\}$ are 16

Note: If $n(A) = n$ then the total number of Subsets are 2^n

Here for $A = \{1, 4, 9, 16\}$, $n(A) = 4$

\therefore Total number of subsets of $A = 2^4 = 16$

(5) If $A = \{1, 2, 3, 4\}$; $B = \{1, 2, 3, 4, 5, 6, 7, 8\}$ then find $A \cup B$, $A \cap B$.

What do you notice about the results? (Problem solving)

Solution: Given $A = \{1, 2, 3, 4\}$

$B = \{1, 2, 3, 4, 5, 6, 7, 8\}$

$A \cup B = \{1, 2, 3, 4\} \cup \{1, 2, 3, 4, 5, 6, 7, 8\} = \{1, 2, 3, 4, 5, 6, 7, 8\} = B$

$A \cap B = \{1, 2, 3, 4\} \cap \{1, 2, 3, 4, 5, 6, 7, 8\} = \{1, 2, 3, 4\} = A$

We observe that if $A \subset B$ then $A \cup B = B$, $A \cap B = A$

(6) If $A = \{2, 3, 5\}$, find $A \cup \phi$, $\phi \cup A$ and $A \cap \phi$, $\phi \cap A$ and compare.

(Problem Solving)

Solution: Given $A = \{2, 3, 5\}$, $\phi = \{ \}$

$A \cup \phi = \{2, 3, 5\} \cup \{ \} = \{2, 3, 5\} = A$

$\phi \cup A = \{ \} \cup \{2, 3, 5\} = \{2, 3, 5\} = A$

$\therefore A \cup \phi = \phi \cup A = A$

$A \cap \phi = \{2, 3, 5\} \cap \{ \} = \{ \} = \phi$

$$\phi \cap A = \{ \} \cap \{ 2, 3, 5 \} = \{ \} = \phi$$

$$\therefore A \cap \phi = \phi \cap A = A \cap B$$

- (7) If $A = \{ 2, 4, 6, 8, 10 \}$, $B = \{ 3, 6, 9, 12, 15 \}$ then find $A - B$ and $B - A$.
Are they equal? Are they disjoint Sets. (Problem solving)

Solution: Given $A = \{ 2, 4, 6, 8, 10 \}$, $B = \{ 3, 6, 9, 12, 15 \}$

$$A - B = \{ 2, 4, 8, 10 \},$$

$$B - A = \{ 3, 6, 9, 12, 15 \}$$

We observe that $A - B \neq B - A$ and $A - B, B - A$ are disjoint Sets.

- (8) Illustrate $A - B$ and $B - A$ in Venn - diagrams.
where $A = \{ 1, 2, 3, 4, 5, 6 \}$ and $B = \{ 2, 4, 6, 8, 10 \}$
(Visualization & Representation)

Solution: Given $A = \{ 1, 2, 3, 4, 5, 6 \}$; $B = \{ 2, 4, 6, 8, 10 \}$

$$A - B = \{ 1, 3, 5 \}, B - A = \{ 8, 10 \}$$

The Venn diagram of $A - B$

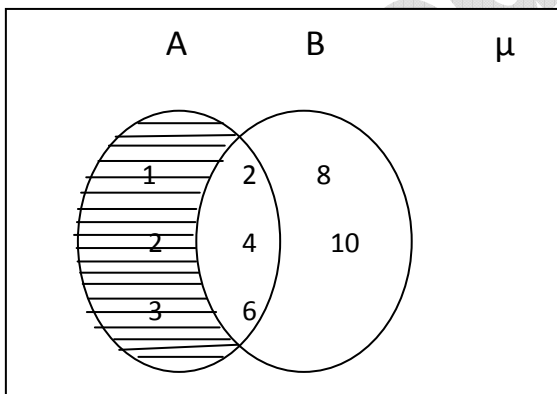

$$A - B = \{ 1, 3, 5 \}$$

The Venn diagram of $B - A$

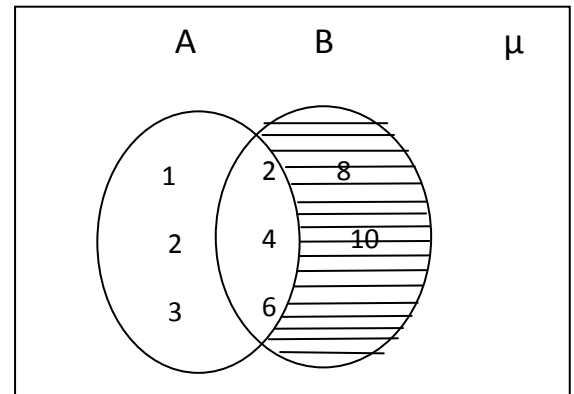

$$B - A = \{ 8, 10 \}$$

Very Short Answer Questions

(1) Give example for a set (communication)

Solution: $A = \{ 2, 3, 5, 7, 11 \} = \{ x: x \text{ is a prime number less than } 13 \}$

(2) Given example for an infinite and finite set (communication)

Solution: $A = \{ x: x \text{ is a multiple of } 7 \}$

$= \{ 7, 14, 21, 28, \dots \}$

$B = \{ x: x \text{ is a multiple of } 4 \text{ between } 17 \text{ and } 61 \text{ which are divisible by } 7 \}$

$= \{ 28, 56 \}$ is a finite set

(3) Given example for an empty set and a non – empty set

Solution: $A = \{ x: 1 < x < 2, x \text{ is a natural number} \} = \{ \}$ is an empty set .

$B = \{ x: x \in \mathbb{N}, x < 5 \text{ and } x > 7 \} = \{ 1, 2, 3, 4, 8, 9, \dots \}$

Is a non – empty set.

(4) Show that the sets A and B are equal.

$A = \{ x: x \text{ is a letter in the word "ASSASSINATION"} \}$

$B = \{ x: x \text{ is a letter in the word "STATION"} \}$ (Reasoning proof)

Solution: In roster form A and B can be written as

$A = \{ A, S, I, N, T, O \}$

$B = \{ A, S, I, N, T, O \}$

So , the elements of A and B are same

\therefore A, B are equal Sets.

(5) $A = \{ \text{quadrilaterals} \}$, $B = \{ \text{Square , rectangle, trapezium, rhombus} \}$

State whether $A \subset B$ or $B \subset A$. Justify your answer.

Solution: Given $A = \{ \text{quadrilaterals} \}$

$B = \{ \text{Square , rectangle, trapezium, rhombus} \}$

All quadrilaterals need not be square or rectangle or trapezium or rhombus.

Hence $A \not\subset B$

Square, rectangle ,trapezium and rhombus are quadrilaterals.

Hence $B \subset A$.

(6) If $A = \{ 5, 6, 7, 8 \}$ and $B = \{ 7, 8, 9, 10 \}$ then find $n(A \cap B)$ and $n(A \cup B)$
(Problem solving)

Solution : Given $A = \{ 5, 6, 7, 8 \}$
 $B = \{ 7, 8, 9, 10 \}$

$$A \cap B = \{ 7, 8 \}$$

$$A \cup B = \{ 5, 6, 7, 8, 9, 10 \}$$

$$n(A \cap B) = 2$$

$$n(A \cup B) = 6$$

(7) If $A = \{ 1, 2, 3, 4 \}$; $B = \{ 1, 2, 3, 5, 6 \}$ then find $A \cap B$ and $B \cap A$. Are they equal? (Problem Solving)

Solution: Given $A = \{ 1, 2, 3, 4 \}$

$B = \{ 1, 2, 3, 5, 6 \}$

$$A \cap B = \{ 1, 2, 3, 4 \} \cap \{ 1, 2, 3, 5, 6 \} = \{ 1, 2, 3 \}$$

$$B \cap A = \{ 1, 2, 3, 5, 6 \} \cap \{ 1, 2, 3, 4 \} = \{ 1, 2, 3 \}$$

We observe that $A \cap B = B \cap A$

(8). Write the set builder form of $A \cup B$, $A \cap B$ and $A - B$ (communication)

Solution:

$$A \cup B = \{ x: x \in A \text{ or } x \in B \}$$

$$A \cap B = \{ x: x \in A \text{ and } x \in B \}$$

$$A - B = \{ x: x \in A \text{ and } x \notin B \}$$

(9). Give example for disjoint sets. (Communication)

Solution:

The Set of even number and the Set of odd number are disjoint sets,

Note: If $A \cap B = \phi$ then A, B are disjoint sets.

Object Type Question

- (1) The symbol for a universal Set []
(A) μ (B) ϕ (C) \subset (D) \cap
- (2) If $A = \{a, b, c\}$, the number of subsets of A is []
(A) 3 (B) 6 (C) 8 (D) 12
- (3) Which of the following sets are equal []
(A) $A = \{1, -1\}$, $B = \{1^2, (-1)^2\}$ (B) $A = \{0, a\}$, $B = \{b, 0\}$
(C) $A = \{2, 4, 6\}$, $B = \{1, 3, 5\}$ (D) $A = \{1, 4, 9\}$, $B = \{1^1, 2^2, 3^2\}$
- (4) Which of the following Set is not null Set ? []
(A) $\{x: 1 < x < 2, x \text{ is a natural number}\}$
(B) $\{x: x^2 - 2 = 0 \text{ and } x \in \mathbb{Q}\}$
(C) $\{x: x^2 = 4, x \text{ is odd}\}$
(D) $\{x: x \text{ is a prime number divisible by } 2\}$
- (5) which of the following Set is not infinite ? []
(A) $\{1, 2, 3, \dots, 100\}$ (B) $\{x: x^2 \text{ is positive, } x \in \mathbb{Z}\}$
(C) $\{x: x \in \mathbb{N}, x \text{ is prime}\}$ (D) $\{3, 5, 7, 9, \dots\}$

(6) Which of the following set is not finite []

(A) $\{x : x \in \mathbb{N}, x < 5 \text{ and } x > 7\}$ (B) $\{x : x \text{ is even prime}\}$

(C) $\{x : x \text{ is a factor of } 42\}$ (D) $\{x : x \text{ is a multiple of } 3, x < 40\}$

(7) The set builder form of $A \cap B$ is []

(A) $\{x : x \in A \text{ and } x \notin B\}$ (B) $\{x : x \in A \text{ or } x \in B\}$

(C) $\{x : x \in A \text{ and } x \in B\}$ (D) $\{x : x \in B \text{ and } x \notin A\}$

(8) For ever set A , $A \cap \phi =$ []

(A) A (B) ϕ (C) μ (D) 0

(9). Two Sets A and B are said to be disjoint if []

(A) $A - B = \phi$ (B) $A \cup B = \phi$ (C) $A \cap B = B \cap A$ (D) $A \cap B = \phi$

(10) The Shaded region in the adjacent figure is []

(A) $A - B$ (B) $B - A$ (C) $A \cap B$ (D) $A \cup B$

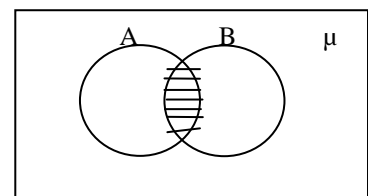

(11) $A = \{x : x \text{ is a circle in a give plane}\}$ is []

(A) Null Set (B) Finite Set (C) Infinite Set (D) Universal Set

(12) $n(A \cup B) = \dots\dots\dots$ []

(A) $n(A) + n(B)$ (B) $n(A) + n(B) - n(A \cap B)$

(C) $n(A) - n(B)$ (D) $n(A) + n(B) + n(A \cap B)$

(13) If A is subset of B, then $A - B = \dots\dots\dots$ []

(A) ϕ (B) A (C) B (D) $A \cap B$

(14) If $A = \{ 1, 2, 3, 4, 5 \}$ then the cardinal number of A is $\dots\dots\dots$ []

(A) 2^5 (B) 5 (C) 4 (D) 5^2

(15) $A = \{ 2, 4, 6, 8, 10 \}$, $B = \{ 1, 2, 3, 4, 5 \}$ then $B - A = \dots\dots\dots$ []

(A) $\{ 6, 8, 10 \}$ (B) $\{ 1, 3, 5 \}$ (C) $\{ 2, 4 \}$ (D) All the above

(16) Which Statement is true $\dots\dots\dots$ []

(A) $A - B$, $B - A$ are disjoint sets

(B) $A - B$, $A \cap B$ are disjoint sets

(C) $A \cap B$, $B - A$ are disjoint sets

(D) All the above

(17) $A \subset B$ then $A \cap B = \dots\dots\dots$ []

(A) A (B) B (C) ϕ (D) $A \cup B$

(18) $A \subset B$ then $A \cup B = \dots\dots\dots$ []

- (A) A (B) B (C) ϕ (D) $A \cap B$

(19) The shaded region in the adjacent figure represents []

- (A) $A - B$ (B) $B - A$ (C) $A \cap B$ (D) $A \cup B$

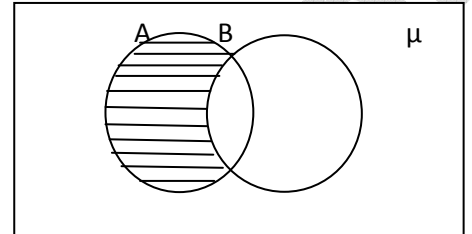

(20) From the figure []

- (A) $A - B = \{ 1, 2, \}$ (B) $A \cap B = \{ 3 \}$
(C) $B - A = \{ 4, 5 \}$ (D) All the above

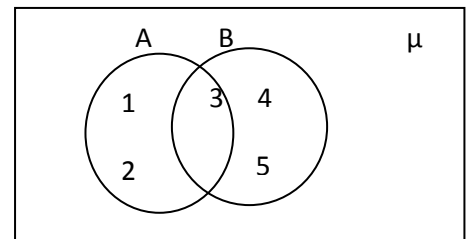

Key:

1. A 2. C 3. D 4. D 5. A 6. A 7. C 8. B 9. D 10. C
11. C 12. B 13. A 14. B 15. B 16. D 17. A 18. B 19. A 20. D

Fill in the Blanks

- (1) The Symbol for null set = ϕ
- (2) Roster form of $\{x: x \in \mathbb{N}, 9 \leq x \leq 16\}$ is = $\{9, 10, 11, 12, 13, 14, 15, 16\}$
- (3) If $A \subset B$ and $B \subset A$ then $A = B$
- (4) If $A \subset B$ and $B \subset C$ then = $A \subset C$
- (5) $A \cup \phi =$ A
- (6) The Set theory was developed by = George cantor
- (7) If $n(A) = 7$, $n(B) = 8$, $n(A \cap B) = 5$ then $n(A \cup B) =$ 10
- (8) A set is a Well defined collection of objects.
- (9) Every set is Subset of itself.
- (10) The number of elements in a set is called the cardinal number of the set.
- (11) $A = \{2, 4, 6, \dots\}$, $B = \{1, 3, 5, \dots\}$ then $n(A \cap B) =$ 0
- (12) A and B are disjoint sets then $A - B =$ A
- (13) If $A \cup B = A \cap B$ then $A = B$
- (14) $A = \{x: x^2 = 4 \text{ and } 3x = 9\}$ is a null set
- (15) $A = \{2, 5, 6, 8\}$ and $B = \{5, 7, 9, 1\}$ then $A \cup B =$ $\{1, 2, 5, 6, 7, 8, 9\}$.
- (16) If $A \subset B$, $n(A) = 3$, $n(B) = 5$, then $n(A \cap B) =$ 3
- (17) If $A \subset B$, $n(A) = 3$, $n(B) = 5$, then $n(A \cup B) =$ 5
- (18) A, B are disjoint sets then $(A - B) \cap (B - A) =$ ϕ
- (19) $A = \{1, 2, 3, 4\}$ and $B = \{2, 4, 6, 8\}$ then $B - A =$ $\{6, 8\}$
- (20) Set builder form of $A \cup B$ is = $\{x: x \in A \text{ or } x \in B\}$

Chapter –4

Pair of Linear Equations in Two Variables

Key Points:

•An equation of the form $ax + by + c = 0$, where a, b, c are real numbers ($a \neq 0, b \neq 0$) is called a linear equation in two variables x and y .

Ex: (i) $4x - 5y + 2 = 0$

(ii) $3x - 2y = 4$

•The general form for a pair of linear equations in two variables x and y is

$$a_1x + b_1y + c_1 = 0$$

$$a_2x + b_2y + c_2 = 0$$

Where $a_1, b_1, c_1, a_2, b_2, c_2$ are all Real Numbers and $a_1 \neq 0, b_1 \neq 0, a_2 \neq 0, b_2 \neq 0$.

Examples

•Graphical representation of a Pair of Linear Equations in two variables:

$$a_1x + b_1y + c_1 = 0$$

$$a_2x + b_2y + c_2 = 0$$

(i) Will represent intersecting lines if

i.e. unique solution. And this type of equations are called consistent pair of linear equations.

Ex: $5x - 2y = 0$

$$3x + 9y - 20 = 0$$

(ii) Will represent overlapping or coincident lines if

i.e. Infinitely many solutions, consistent or dependent pair of linear equations

Ex: $2x + 3y - 9 = 0$,

$$4x + 6y - 20 = 0$$

(iii) Will represent parallel lines if

i.e. no solution and called inconsistent pair of linear equations

Ex: $x + 2y - 4 = 0$

$$2x + 4y - 12 = 0$$

(iv) Algebraic methods of solving a pair of linear equations:

(i) Substitution method

(ii) Elimination Method

(iii) Cross multiplication method

System	No of solutions	Nature of lines
Consistent	Unique solution	Intersecting lines
Consistent	Infinite solutions	Coincident lines
Inconsistent	No solution	Parallel lines

Short Type Questions

1. The ratio of incomes of two persons is 9 : 7 and the ratio of their expenditures is 4 : 3. If each of them manages to save Rs 2000 per month, find their monthly income?

Sol: Let the monthly income be Rs x

Monthly Expenditure be Rs y

Ratio of incomes of two persons = 9 : 7

Income of first person = Rs 9x

Income of second person = Rs. 7x

Expenditure of first person = Rs 4y

Expenditure of second person = Rs 3y

Each one savings per month = Rs 2000

As per problem

$$9x - 4y = 2000 \rightarrow (1)$$

$$7x - 3y = 2000 \rightarrow (2)$$

$$(1) \times 3 \Rightarrow 27x - 12y = 6000$$

$$(2) \times 4 \Rightarrow 28x - 12y = 8000$$

$$\begin{array}{r} - \quad + \quad - \\ \hline x \qquad \qquad = + 2000 \end{array}$$

Income of first person = $9 \times 2000 = \text{Rs. } 18000$

Income of second person = $7 \times 2000 = \text{Rs. } 14000.$

2.The sum of a two digit number and the number obtained by reversing the digits is 66. If the digits of the number differ by 2, find the number how many such numbers are there?

Sol: Let the number in the units place = x

Ten's place = y

∴ The number = 10 y + x

On reversing the digits = 10x + y

According to the problem

$$(10y + x) + (10x + y) = 66$$

$$x + y = 6 \rightarrow (1)$$

Difference of the digits = 2

$$x - y = 2 \rightarrow (2)$$

$$x + y = 6$$

$$x - y = 2$$

$$\hline 2x = 8$$

$$x = 4$$

Substitute the value of x in eq (1) or (2)

$$x - y = 2$$

$$4 - y = 2 \Rightarrow y = 2$$

∴ The number = 10 × 4 + 2 = 42

There are only numbers possible ie 42 and 24.

3.The larger of two complementary angles exceeds the smaller by 18°. Find the angles .

Sol: Let the larger complementary angle be x°

The smaller complementary angle be y°

As per problem

$$x = y + 18$$

$$x - y = 18 \rightarrow (1)$$

Sum of the supplementary angles is 90°

$$x + y = 90^\circ \rightarrow (2)$$

$$x - y = 18$$

$$\underline{x + y = 90}$$

$$2x = 108$$

$$x = 54$$

Substitute the value of x in (1) or (2)

$$x - y = 18$$

$$54 - y = 18 \Rightarrow y = 36^\circ.$$

4. Two angles are supplementary. The larger angle is 3° less than twice the measure of the smaller angle. Find the measure of each angle.

Sol: Let the larger supplementary angle be x°

Smaller supplementary angle be y°

As per problem

$$x = 2y - 3 \rightarrow (1)$$

Sum of the supplementary angles is 180°

$$x + y = 180 \rightarrow (2)$$

$$x + y = 180$$

$$x - 2y = -3$$

$$\underline{- + \quad +}$$

$$3y = 183 \Rightarrow y = 61$$

Substitute the value of y in (1) or (2)

$$x + y = 180$$

$$x + 61 = 180 \Rightarrow x = 119^\circ$$

\therefore Two angles are $119^\circ, 61^\circ$.

5. Mary told her daughter seven years ago, I was seven Times as old as you were then also three years from now, I shall be three times as old as you will be find the present age of Mary and her daughter.

Sol: Let Mary's present age be x years and her daughter's age be y years.

Then, seven years ago Mary's age was $x - 7$ and

Daughter's age was $y - 7$

As per problem

$$x - 7 = 7(y - 7)$$

$$x - 7y + 42 = 0 \rightarrow (1)$$

Three years hence, Mary's age will be $x + 3$ and

Daughter's age will be $y + 3$

$$x + 3 = 3(y + 3)$$

$$x - 3y - 6 = 0 \rightarrow (2)$$

$$x - 7y = -42$$

$$x - 3y = 6$$

$$\begin{array}{r} - \quad + \quad - \\ \hline -4y = -48 \Rightarrow y = 12 \end{array}$$

Substitute the value of y in (1) or (2)

$$x - 3y = 6$$

$$x - 36 = 6 \Rightarrow x = 42$$

\therefore Mary's present age is 42 years and her daughter's age is 12 years.

6. An Algebra text book has a total of 1382 pages. It is broken up into two parts the second part of the book has 64 pages more than the first part. How many pages are in each part of the book?

Sol: Let the first part be x pages

The second part be y pages

Total number of pages = 1382 $\Rightarrow x + y = 1382 \rightarrow (1)$

According problem

$$y = x + 64$$

$$x - y = -64 \rightarrow (2)$$

$$x + y = 1382$$

$$x - y = -64$$

$$2x = 1318$$

$$x = \frac{1318}{2} = 659$$

Substitute the value of x in (1) or (2)

$$x - y = -64$$

$$659 - y = -64$$

$$723 = y$$

∴ Number of pages in each part 659 and 723

7.A chemical has two solutions of hydrochloric acid in stock one is 50% solution and the other is 80% solution. How much of each should be used to obtain 100 ml of a 68% solution.

Sol: Let the first solution be x ml

Second solution be y ml

Total solution is 100ml

$$x + y = 100\text{ml} \rightarrow (1)$$

According to the problems

50% of solution + 80% of solution = 68

$$\frac{50}{100}x + \frac{80}{100}y = 68$$

$$5x + 8y = 680 \rightarrow (2)$$

$$(1) \times 5 \Rightarrow 5x + 5y = 500$$

$$5x + 8y = 680$$

$$+ 3y = + 180$$

$$y = 60$$

substitute the value of y in (1) or (2)

$$x + y = 100$$

$$x + 60 = 100 \Rightarrow x = 40$$

\therefore First and second solutions are 40 ml and 60ml.

www.sakshieducation.com

Essay Type Questions

1. A man travels 370 km partly by train and partly by car. If he covers 250 km by train and the rest by car, it takes him 4 hours. But if he travels 130 km by train and the rest by car, it takes 18 minutes more. Find the speed of the train and that of the car.

Sol: Let the speed of the train be x km/hour

Speed of the car be y km/hour

We know that $\text{time} = \frac{\text{speed}}{\text{distance}}$

Case (1) time spent travelling by train = $\frac{250}{x}$ hours

Time spent travelling by car = $\frac{120}{y}$ hours

Total time taken = $\frac{250}{x} + \frac{120}{y}$

But, total time of journey is 4 hours (given)

$$\frac{250}{x} + \frac{120}{y} = 4$$

$$\frac{125}{x} + \frac{60}{y} = 2 \longrightarrow (1)$$

Case(2): Time spent travelling by train = $\frac{130}{x}$ hours

Time spent travelling by car = $\frac{240}{y}$ hours

Total time taken = $\frac{130}{x} + \frac{240}{y}$

Time of journey is 4 hours 18 mts (given)

$$= \frac{130}{x} + \frac{240}{y} = 4 \frac{18}{60} = 4 \frac{3}{10} \text{ hours}$$

$$= \frac{130}{x} + \frac{240}{y} = \frac{43}{10} \longrightarrow (2)$$

$$\text{Let } \frac{1}{x} = a; \frac{1}{y} = b$$

$$125a + 60b = 2 \longrightarrow (3)$$

$$130a + 240b = \frac{43}{10} \longrightarrow (4)$$

$$(3) \times 4 \Rightarrow 500a + 240b = 8$$

$$130a + 240b = \frac{43}{10}$$

$$\begin{array}{r} - \quad - \quad - \\ \hline 370a \quad = 8 - \frac{43}{10} = \frac{37}{10} \end{array}$$

$$a = \frac{37}{10} \times \frac{1}{370} = \frac{1}{100}$$

Substitute the value of a in (3) or (4)

$$125a + 60b = 2$$

$$125 \times \frac{1}{100} + 60b = 2 \Rightarrow b = \frac{1}{80}$$

$$\text{So } a = \frac{1}{100}; b = \frac{1}{80}$$

$$a = \frac{1}{100} \Rightarrow \frac{1}{x} = \frac{1}{100} \Rightarrow x = 100 \text{ km / hour}$$

$$b = \frac{1}{80} \Rightarrow \frac{1}{y} = \frac{1}{80} \Rightarrow y = 80 \text{ km / hour}$$

Speed of train was 100 km/hour and

Speed of car was 80 km/hour

2. Solve: $\frac{5}{x-1} + \frac{1}{y-2} = 2$

$$\frac{6}{x-1} + \frac{3}{y-2} = 1$$

$$\frac{5}{x-1} + \frac{1}{y-2} = 2$$

Sol:

$$\frac{6}{x-1} + \frac{3}{y-2} = 1$$

Let $\frac{1}{x-1} = a; \frac{1}{y-2} = b$

$$5a + b = 2 \rightarrow (1)$$

$$6a - 3b = 1 \rightarrow (2)$$

$$(1) \times 3 \Rightarrow 15a + 3b = 6$$

$$\begin{array}{r} 6a - 3b = 1 \\ \hline 21a = 7 \end{array}$$

$$a = \frac{1}{3}$$

Substitute the value of a in (1) or (2)

$$5a + b = 2$$

$$5 \cdot \frac{1}{3} + b = 2 \Rightarrow b = \frac{1}{3}$$

$$a = \frac{1}{3} \Rightarrow \frac{1}{x-1} = \frac{1}{3} \Rightarrow x-1 = 3 \Rightarrow x = 4$$

$$b = \frac{1}{3} \Rightarrow \frac{1}{y-2} = \frac{1}{3} \Rightarrow y-2 = 3 \Rightarrow y = 5$$

3. $\frac{2}{\sqrt{x}} + \frac{3}{\sqrt{y}} = 2; \frac{4}{\sqrt{x}} - \frac{9}{\sqrt{y}} = -1$

Sol: $2\left(\frac{1}{\sqrt{x}}\right) + 3\left(\frac{1}{\sqrt{y}}\right) = 2$

$$4\left(\frac{1}{\sqrt{x}}\right) - 9\left(\frac{1}{\sqrt{y}}\right) = -1$$

Let $\frac{1}{\sqrt{x}} = a; \frac{1}{\sqrt{y}} = b$

$$2a + 3b = 2 \rightarrow (1)$$

$$4a - 9b = -1 \rightarrow (2)$$

$$(1) \times 2 \Rightarrow 4a + 6b = 4$$

$$\begin{array}{r}
 4a - 9b = -1 \\
 - \quad + \quad + \\
 \hline
 15b = 5
 \end{array}$$

$$b = \frac{5}{15} = \frac{1}{3}$$

Substitute the value of b in (1)

$$2a + 3b = 2$$

$$2a + 3 \cdot \frac{1}{3} = 2$$

$$2a + 1 = 2 \Rightarrow a = \frac{1}{2}$$

$$a = \frac{1}{2} \Rightarrow \frac{1}{\sqrt{x}} = \frac{1}{2} \Rightarrow \sqrt{x} = 2 \Rightarrow (\sqrt{x})^2 = 2^2 \Rightarrow x = 4$$

$$b = \frac{1}{3} \Rightarrow \frac{1}{\sqrt{y}} = \frac{1}{3} \Rightarrow \sqrt{y} = 3 \Rightarrow (\sqrt{y})^2 = 3^2 \Rightarrow y = 9$$

4. $6x + 3y = 6xy$

$2x + 4y = 5xy$

Sol:

$$6x + 3y = 6xy$$

$$2x + 4y = 5xy$$

$$\frac{6x+3y}{xy} = 6$$

$$\frac{6}{y} + \frac{3}{x} = 6 \rightarrow (1)$$

$$\frac{2x+4y}{xy} = 5$$

$$\frac{2}{y} + \frac{4}{x} = 5 \rightarrow (2)$$

$$\text{Let } \frac{1}{x} = a; \frac{1}{y} = b$$

$$3a + 6b = 6 \rightarrow (3)$$

$$4a + 2b = 5 \rightarrow (4)$$

$$3a + 6b = 6$$

$$(4) \times 3 \Rightarrow 12a + 6b = 15$$

$$\begin{array}{r} - \quad - \quad - \\ \hline -9a = -9 \end{array}$$

$$a = 1$$

Substitute the value of a in (3) or (4)

$$3a + 6b = 6$$

$$3 \times 1 + 6b = 6$$

$$6b = 3, b = \frac{1}{2}$$

$$a = 1 \Rightarrow \frac{1}{x} = 1 \Rightarrow x = 1$$

$$b = \frac{1}{2} \Rightarrow \frac{1}{y} = \frac{1}{2} \Rightarrow y = 2$$

5. $\frac{10}{x+y} + \frac{2}{x-y} = 4$

$$\frac{15}{x+y} - \frac{5}{x-y} = -2$$

Sol:

$$\frac{10}{x+y} + \frac{2}{x-y} = 4$$

$$\frac{15}{x+y} - \frac{5}{x-y} = -2$$

$$\text{Let } \frac{1}{x+y} = a; \frac{1}{x-y} = b$$

$$10a + 2b = 4 \rightarrow (1)$$

$$15a - 5b = -2 \rightarrow (2)$$

$$(1) \times 5 \Rightarrow 50a + 10b = 20$$

$$(2) \times 2 \Rightarrow 30a - 10b = -4$$

$$\underline{80a = 16}$$

$$a = \frac{16}{80} = \frac{1}{5}$$

Substitute the value of a in (1) or (2)

$$15a - 5b = -2$$

$$15. \frac{1}{5} - 5b = -2$$

$$3 - 5b = -2 \Rightarrow -5b = -5 \Rightarrow b = 1$$

$$a = \frac{1}{5} \Rightarrow \frac{1}{x+y} = \frac{1}{5} \Rightarrow x+y = 5$$

$$b = 1 \Rightarrow \frac{1}{x-y} = 1 \Rightarrow x-y = 1$$

$$x + y = 5 \quad \rightarrow (3)$$

$$x - y = 1 \quad \rightarrow (4)$$

$$\underline{2x = 6}$$

$$x = 3$$

Substitute the value of x in (3) or (4)

$$x + y = 5$$

$$3 + y = 5$$

$$y = 2$$

6.
$$\frac{1}{3x+y} + \frac{1}{3x-y} = \frac{3}{4}$$

$$\frac{1}{2(3x+y)} - \frac{1}{2(3x-y)} = -\frac{1}{8}$$

Sol: Let
$$\frac{1}{3x+y} = a; \frac{1}{3x-y} = b$$

$$a + b = \frac{3}{4}$$

$$\frac{a}{2} - \frac{b}{2} = -\frac{1}{8} \Rightarrow a - b = -\frac{1}{4}$$

$$a + b = \frac{3}{4} \rightarrow (1)$$

$$a - b = -\frac{1}{4} \rightarrow (2)$$

$$\begin{array}{r} 2a \\ \hline \end{array} = \frac{3}{4} - \frac{1}{4} = \frac{2}{4} = \frac{1}{2}$$

Substitute the value of a in (1) or (2)

$$a + b = \frac{3}{4}$$

$$\frac{1}{4} + b = \frac{3}{4}$$

$$b = \frac{3}{4} - \frac{1}{4} = \frac{2}{4} = \frac{1}{2}$$

$$a = \frac{1}{4} \Rightarrow \frac{1}{3x+y} = \frac{1}{4} \Rightarrow 3x + y = 4$$

$$b = \frac{1}{2} \Rightarrow \frac{1}{3x-y} = \frac{1}{2} \Rightarrow 3x - y = 2$$

$$3x + y = 4 \rightarrow (3)$$

$$3x - y = 2 \rightarrow (4)$$

$$\begin{array}{r} 6x \\ \hline \end{array} = 6$$

$$x = 1$$

Substitute the value of x in (3) or (4)

$$3x + y = 4$$

$$3.1 + y = 4$$

$$y = 1$$

7. A boat goes 30 km upstream and 44 km downstream in 10 hours. In 13 hours it can go 40 km upstream and 55 km downstream. Determine the speed of the stream and that of the boat in still water?

Sol: Let the speed of the boat = x km/hour

The speed of the stream = y km /hour

Relative speed upstream = $(x - y)$ km/hour

Relative speed downstream = $(x + y)$ km/hour

Distance travelled to upstream = 30 km

$$\text{Time taken to up} = \frac{30}{x-y} \text{ hours}$$

Distance travelled to downstream = 44 km

$$\text{Time taken} = \frac{44}{x+y} \text{ hours}$$

$$\text{Total time taken} = \frac{30}{x-y} + \frac{44}{x+y}$$

Total time taken = 10 hours (Given)

$$\frac{30}{x-y} + \frac{44}{x+y} = 10 \longrightarrow (1)$$

Distance travelled to upstream = 40 km

$$\text{Time taken to up} = \frac{40}{x-y} \text{ hours}$$

Distance travelled to downstream = 55 km

$$\text{Time taken} = \frac{55}{x+y} \text{ hours}$$

Total time taken = 13 hours (Given)

$$\frac{40}{x-y} + \frac{55}{x+y} = 13 \longrightarrow (2)$$

$$\frac{30}{x-y} + \frac{44}{x+y} = 10$$

$$\frac{40}{x-y} + \frac{55}{x+y} = 13$$

$$\text{Let } \frac{1}{x-y} = a; \frac{1}{x+y} = b$$

$$30a + 44b = 10 \rightarrow (3)$$

$$40a + 55b = 13 \rightarrow (4)$$

$$(3) \times 4 \Rightarrow 120a + 176b = 40$$

$$(4) \times 3 \Rightarrow 120a + 165b = 39$$

$$\begin{array}{r} - \quad - \quad - \\ \hline 11b = 1 \Rightarrow b = \frac{1}{11} \end{array}$$

Substitute the value of b in (3) or (4)

$$30a + 44b = 10$$

$$30a + 44 \cdot \frac{1}{11} = 10$$

$$30a = 10 - 4 = 6 \Rightarrow a = \frac{1}{5}$$

$$a = \frac{1}{5} \Rightarrow \frac{1}{x-y} = \frac{1}{5} \Rightarrow x-y = 5$$

$$b = \frac{1}{11} \Rightarrow \frac{1}{x+y} = \frac{1}{11} \Rightarrow x+y = 11$$

$$x - y = 5 \rightarrow (5)$$

$$x + y = 11 \rightarrow (6)$$

$$\begin{array}{r} \hline 2x = 16 \end{array}$$

$$x = 8$$

substitute the value of x in (5) or (6)

$$x + y = 11$$

$$8 + y = 11 \Rightarrow y = 3$$

\therefore Speed of the boat = 8km/hour

Speed of the stream = 3km/hour

8.2 women and 5 men can together finish an embroidery work in 4 days while 3 women and 6 man can finish it in 3 days. Find the time taken by 1 women alone and 1 man alone to finish the work.

Sol: Let the time taken by one women to finish the work = x days

$$\text{Work done by one women in one day} = \frac{1}{x}$$

Let the time taken by are men to finish the work = y days

$$\text{Work done by one man in one day} = \frac{1}{y}$$

According to the problem

2 women and 5 men can together finish an embroidery work in 4 days.

$$\text{Work done by 2 women and 5 man in one day} = \frac{1}{4}$$

$$\text{So work done by 2 women in one day} = 2 \times \frac{1}{x} = \frac{2}{x}$$

$$\text{Work done by 5 men in one day} = 5 \times \frac{1}{y} = \frac{5}{y}$$

$$\text{Total work} = \frac{2}{x} + \frac{5}{y}$$

$$= \frac{2}{x} + \frac{5}{y} = \frac{1}{4} \longrightarrow (1)$$

Also 3 women and 6men can finish the work in 3 days

Work done by 3 women and 6 men in one day

$$= \frac{3}{x} + \frac{6}{y} = \frac{1}{3} \longrightarrow (2)$$

$$\frac{1}{x} = a; \frac{1}{y} = b$$

$$2a + 5b = \frac{1}{4} \longrightarrow (2)$$

$$3a + 6b = \frac{1}{3} \longrightarrow (4)$$

$$(3) \times 3 \Rightarrow 6a + 15b = \frac{3}{4}$$

$$(4) \times 2 \Rightarrow 6a + 12b = \frac{2}{3}$$

$$\begin{array}{r} - \quad - \quad - \\ \hline 3b = \frac{3}{4} - \frac{2}{3} = \frac{9-8}{12} = \frac{1}{12} \end{array}$$

$$b = \frac{1}{36}$$

Substitute 1 value of b in (3) or (4)

$$2a + 5b = \frac{1}{4}$$

$$2a + 5 \cdot \frac{1}{36} = \frac{1}{4}$$

$$2a = \frac{1}{4} - \frac{5}{36} = \frac{9-5}{36} = \frac{4}{36}$$

$$a = \frac{4}{36} \times \frac{1}{2} = \frac{1}{18}$$

$$a = \frac{1}{18} \Rightarrow \frac{1}{x} = \frac{1}{18} \Rightarrow x = 18$$

$$b = \frac{1}{36} \Rightarrow \frac{1}{y} = \frac{1}{36} \Rightarrow y = 36$$

Time taken by one women to finish the work = 18days

Time taken by one men to finish the work = 36 days.

Graphical method of finding solution of a pair of linear equations

1.10 students of class – X took part in a maths quiz. If the number of girls is 4 more than number of boys then find the number of boys and the number of girls who took part in the quiz.

Sol: Let the number of boys = x

The number of girls = y

Total number of students took part in maths quiz = 10

$$x + y = 10 \rightarrow (1)$$

if the number of girls is 4 more than no.of boys $y = x + 4$

$$x - y = -4 \rightarrow (1)$$

$$x + y = 10$$

$$y = 10 - x$$

x	$y = 10 - x$	(x, y)
0	$y = 10$	(0, 10)
2	$y = 8$	(2, 8)
4	$y = 6$	(4, 6)
6	$y = 4$	(6, 4)

$$x - y = -4$$

$$y = x + 4$$

x	y	(x, y)
0	4	(0, 4)
2	6	(2, 6)
4	8	(4, 8)
6	10	(6, 10)

\therefore Number of boys = 3

Number of girls = 7

1

Scale

x-axis 1 unit = 1cm

y-axis 1 unit = 2cm

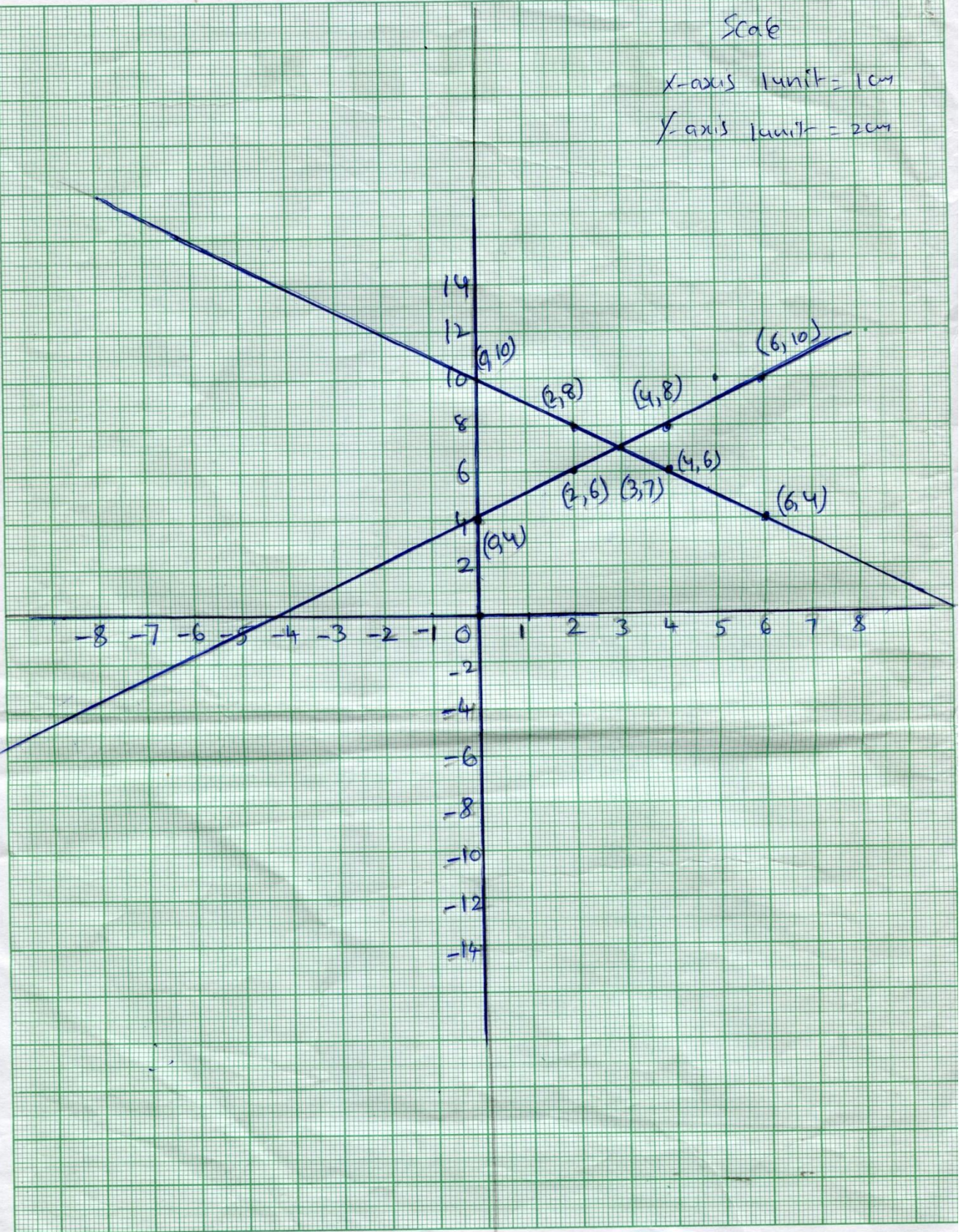

2.5 pencils and 7 pens together cost Rs 50. Where as 7 pencils and 5 pen together cost Rs. 46. Find the cost of one pencils and one pen?

Sol: Cost of one pencil is Rs x

Cost of one pen is Rs y

5 pencils and 7 pens together cost = Rs50

$$5x + 7y = 50 \rightarrow (1)$$

7 pencils and 5 pens together cost = Rs. 46

$$7x + 5y = \text{Rs } 46 \rightarrow (2)$$

$$5x + 7y = 50$$

$$y = \frac{50 - 5x}{7}$$

x	y	(x, y)
0	$\frac{50}{7} = 7.1$	(0, 7.1)
1	$\frac{45}{7} = 6.5$	(1, 6.5)
2	$\frac{40}{7} = 5.7$	(2, 5.7)

$$7x + 5y = 46$$

$$y = \frac{46 - 7x}{5}$$

x	y	(x, y)
0	9.2	(0, 9.2)
1	7.8	(1, 7.8)
2	6.2	(2, 6.2)

Cost of a pencil = Rs 3.

Cost of a pen = Rs 5.

2

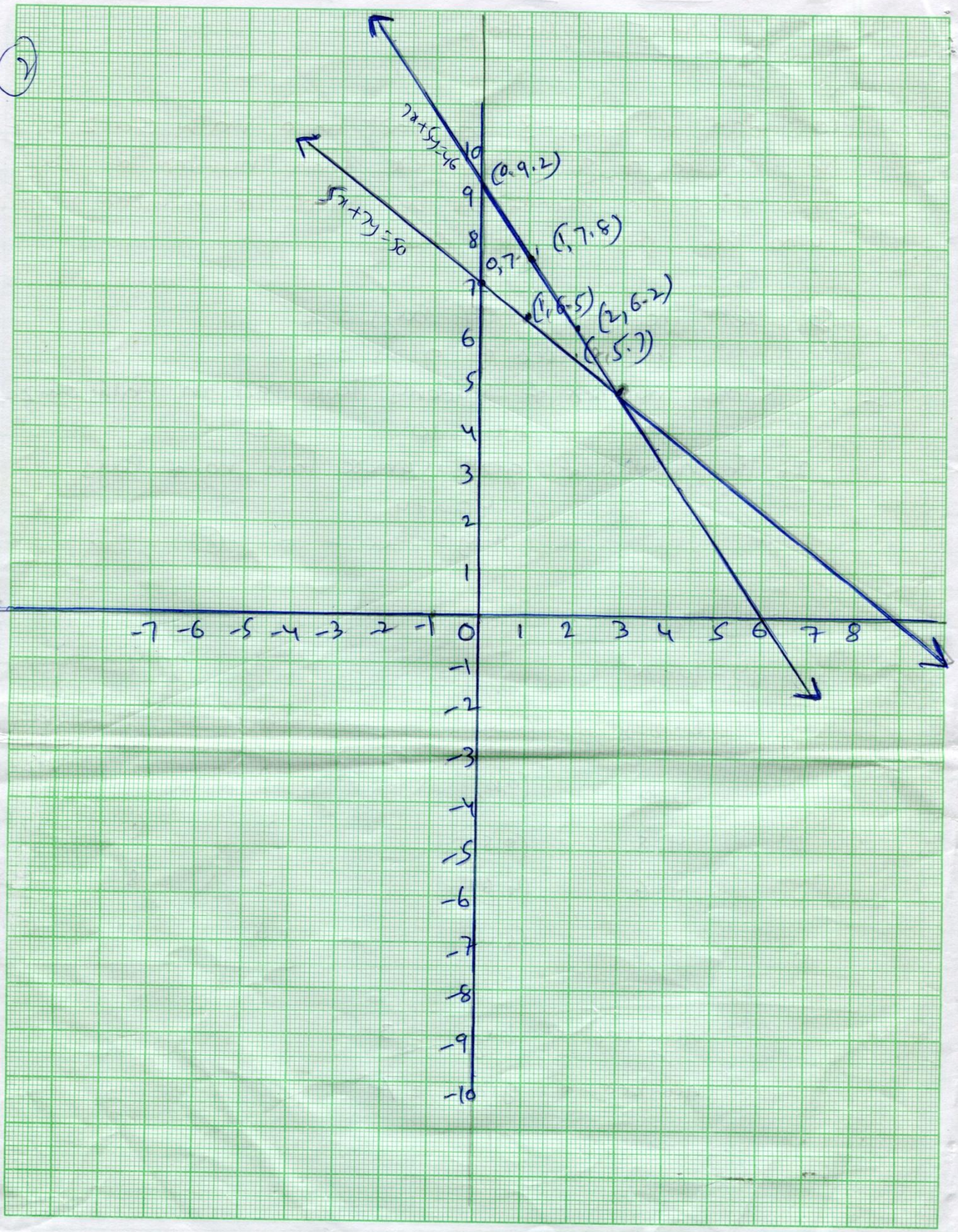

3. The perimeter of a rectangular plot is 32m. If the length is increased by 2m and the breadth is decreased by 1m. The area of the plot remains the same. Find the length and breadth of the plot.

Sol: Let the length and breadth of Rectangular plot is l and b m.

$$\text{Area of rectangle} = lb \text{ units}$$

$$\text{Perimeter} = 2(l + b) = 32$$

When length is increased by 2m and the breadth is decreased by 1m. Then

$$\text{area} = (l + 2)(b - 1)$$

Since there is no change in the area

$$(l + 2)(b - 1) = lb$$

$$l - 2b + 2 = 0 \rightarrow (2)$$

$$l + b - 16 = 0$$

l	b	(l, b)
6	10	(6, 10)
8	8	(8, 8)
10	6	(10, 6)
12	4	(12, 4)
14	2	(14, 2)

$$l - 2b + 2 = 0$$

l	b	(l, b)
6	4	(6, 4)
8	5	(8, 5)
10	6	(10, 6)
12	7	(12, 7)
14	8	(14, 8)

3

Scale

X-axis (unit = 2cm)

Y-axis (unit = 2cm)

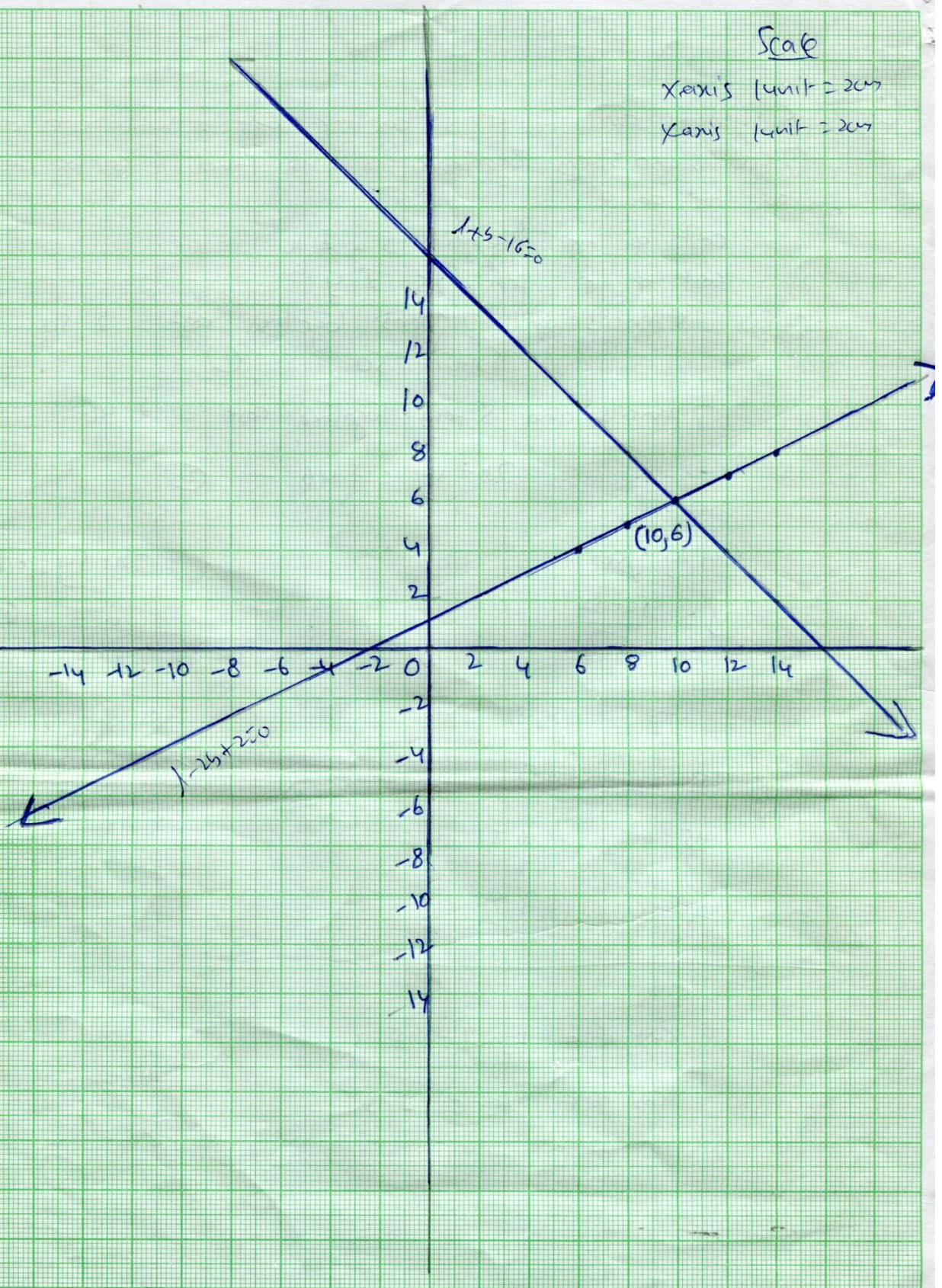

Fill in the blanks:

- 1) An equation of the form $ax+by+c=0$ where a,b,c are real numbers and where atleast one of a or b is not zero is called equation.
- 2) The general form of linear equation is
- 3) A linear equation in two variables has solutions.
- 4) The graph of a linear equation in two variables is a
- 5) Two lines are drawn in the same plane , then the lines may intersect at point.
- 6) The graph of a pair of linear equations in two variables then the lines intersect at a one point gives the solution of the equations.
- 7) If the lines coincide then they are solutions.
- 8) If the lines are parallel then the pair of equations has solutions.
- 9) $3x+2y=5, 2x-3y=7$ then the pair of linear equations is
- 10) $2x-3y=8, 4x-6y=9$ then the pair of linear equations is
- 11) Sum of the complimentary angles is
- 12) Sum of the supplementary angles is
- 13) Time=.....
- 14) The value of x in the equation $2x-(4-x)=5-x$ is
- 15) The equation $x-4y=5$ has solutions.
- 16) The sum of two numbers is 80 and their ratio is 3:5 then the first number is
- 17) The value of x in the equation $5x-8=2x-2$ is
- 18) For what value of P the following pair of equations has unique solution $2x+py=-5, 3x+3y=-6$ is
- 19) A system of two linear equations in two variables is said to be constant if it has at least solutions.
- 20) No of solutions for the equation $3(7-3y)+4y=16$ is.....
- 21) A system of linear equations in two variables is said to be inconsistent if it has solutions.

- 22) When two lines in the same plane may intersect is.....
- 23) $3x+2y-80=0$, $4x+3y-110=0$ solution for this linear equation is
- 24) $X+2y-30=0$, $2x+4y-66=0$ these lines represent
- 25) $4x+9y-13=0$ no of unknowns in this linear equation is
- 26) In the equation $4x+3y-4=0$ then $a=.....$, $c=.....$
- 27) Sum of two numbers is 44 then the equation form is
- 28) $4x-2y=0$, $2x-3y=0$ then $a_1=.....$, $c_1=.....$
- 29) The difference of two numbers is 48 then the equation is _____
- 30) A_____ in two variables can be solved using various methods.

ANSWERS

- | | | | | |
|-----------------------------|-------------------|-------------------|-----------------|-----------------------------|
| 1.Linear | 2. $ax+by+c=0$ | 3.Many | 4.Straight line | 5.one |
| 6.Unique | 7.Infinetely | 8.No | 9.Consistent | 10.Inconsistent |
| 11. 90^0 | 12. 180^0 | 13.Distance/speed | | 14.9/4 |
| 15.Infinetly many solutions | | 16.30 | 17. $x=2$ | 18. $P=3$ |
| 19.One | 20.Unique | 21.NO | | 22.Onepoint |
| 23.Unique | 24.Parallel lines | 25.Two | | 26.4,-4 |
| 27. $x+y=44$ | 28.4,0 | 29. $x-y=48$ | | 30.pair of linear equations |

Chapter –4

Pair of Linear Equations in Two Variables

Key Points:

•An equation of the form $ax + by + c = 0$, where a, b, c are real numbers ($a \neq 0, b \neq 0$) is called a linear equation in two variables x and y .

Ex: (i) $4x - 5y + 2 = 0$

(ii) $3x - 2y = 4$

•The general form for a pair of linear equations in two variables x and y is

$$a_1x + b_1y + c_1 = 0$$

$$a_2x + b_2y + c_2 = 0$$

Where $a_1, b_1, c_1, a_2, b_2, c_2$ are all Real Numbers and $a_1 \neq 0, b_1 \neq 0, a_2 \neq 0, b_2 \neq 0$.

Examples

•Graphical representation of a Pair of Linear Equations in two variables:

$$a_1x + b_1y + c_1 = 0$$

$$a_2x + b_2y + c_2 = 0$$

(i) Will represent intersecting lines if

i.e. unique solution. And this type of equations are called consistent pair of linear equations.

Ex: $5x - 2y = 0$

$$3x + 9y - 20 = 0$$

(ii) Will represent overlapping or coincident lines if

i.e. Infinitely many solutions, consistent or dependent pair of linear equations

Ex: $2x + 3y - 9 = 0$,

$$4x + 6y - 20 = 0$$

(iii) Will represent parallel lines if

i.e. no solution and called inconsistent pair of linear equations

Ex: $x + 2y - 4 = 0$

$$2x + 4y - 12 = 0$$

(iv) Algebraic methods of solving a pair of linear equations:

(i) Substitution method

(ii) Elimination Method

(iii) Cross multiplication method

System	No of solutions	Nature of lines
Consistent	Unique solution	Intersecting lines
Consistent	Infinite solutions	Coincident lines
Inconsistent	No solution	Parallel lines

Short Type Questions

1. The ratio of incomes of two persons is 9 : 7 and the ratio of their expenditures is 4 : 3. If each of them manages to save Rs 2000 per month, find their monthly income?

Sol: Let the monthly income be Rs x

Monthly Expenditure be Rs y

Ratio of incomes of two persons = 9 : 7

Income of first person = Rs 9x

Income of second person = Rs. 7x

Expenditure of first person = Rs 4y

Expenditure of second person = Rs 3y

Each one savings per month = Rs 2000

As per problem

$$9x - 4y = 2000 \rightarrow (1)$$

$$7x - 3y = 2000 \rightarrow (2)$$

$$(1) \times 3 \Rightarrow 27x - 12y = 6000$$

$$(2) \times 4 \Rightarrow 28x - 12y = 8000$$

$$\begin{array}{r} - \quad + \quad - \\ \hline x \qquad \qquad = + 2000 \end{array}$$

Income of first person = $9 \times 2000 = \text{Rs. } 18000$

Income of second person = $7 \times 2000 = \text{Rs. } 14000.$

2. The sum of a two digit number and the number obtained by reversing the digits is 66. If the digits of the number differ by 2, find the number how many such numbers are there?

Sol: Let the number in the units place = x

Ten's place = y

∴ The number = $10y + x$

On reversing the digits = $10x + y$

According to the problem

$$(10y + x) + (10x + y) = 66$$

$$x + y = 6 \rightarrow (1)$$

Difference of the digits = 2

$$x - y = 2 \rightarrow (2)$$

$$x + y = 6$$

$$\underline{x - y = 2}$$

$$2x = 8$$

$$x = 4$$

Substitute the value of x in eq (1) or (2)

$$x - y = 2$$

$$4 - y = 2 \Rightarrow y = 2$$

∴ The number = $10 \times 4 + 2 = 42$

There are only numbers possible ie 42 and 24.

3. The larger of two complementary angles exceeds the smaller by 18° . Find the angles.

Sol: Let the larger complementary angle be x°

The smaller complementary angle be y°

As per problem

$$x = y + 18$$

$$x - y = 18 \rightarrow (1)$$

Sum of the supplementary angles is 90°

$$x + y = 90^\circ \rightarrow (2)$$

$$x - y = 18$$

$$\underline{x + y = 90}$$

$$2x = 108$$

$$x = 54$$

Substitute the value of x in (1) or (2)

$$x - y = 18$$

$$54 - y = 18 \Rightarrow y = 36^\circ.$$

4. Two angles are supplementary. The larger angle is 3° less than twice the measure of the smaller angle. Find the measure of each angle.

Sol: Let the larger supplementary angle be x°

Smaller supplementary angle be y°

As per problem

$$x = 2y - 3 \rightarrow (1)$$

Sum of the supplementary angles is 180°

$$x + y = 180 \rightarrow (2)$$

$$x + y = 180$$

$$x - 2y = -3$$

$$\underline{- + \quad +}$$

$$3y = 183 \Rightarrow y = 61$$

Substitute the value of y in (1) or (2)

$$x + y = 180$$

$$x + 61 = 180 \Rightarrow x = 119^\circ$$

\therefore Two angles are $119^\circ, 61^\circ$.

5. Mary told her daughter seven years ago, I was seven Times as old as you were then also three years from now, I shall be three times as old as you will be find the present age of Mary and her daughter.

Sol: Let Mary's present age be x years and her daughter's age be y years.

Then, seven years ago Mary's age was $x - 7$ and

Daughter's age was $y - 7$

As per problem

$$x - 7 = 7(y - 7)$$

$$x - 7y + 42 = 0 \rightarrow (1)$$

Three years hence, Mary's age will be $x + 3$ and

Daughter's age will be $y + 3$

$$x + 3 = 3(y + 3)$$

$$x - 3y - 6 = 0 \rightarrow (2)$$

$$x - 7y = -42$$

$$x - 3y = 6$$

$$\begin{array}{r} - \quad + \quad - \\ \hline -4y = -48 \Rightarrow y = 12 \end{array}$$

Substitute the value of y in (1) or (2)

$$x - 3y = 6$$

$$x - 36 = 6 \Rightarrow x = 42$$

\therefore Mary's present age is 42 years and her daughter's age is 12 years.

6. An Algebra text book has a total of 1382 pages. It is broken up into two parts the second part of the book has 64 pages more than the first part. How many pages are in each part of the book?

Sol: Let the first part be x pages

The second part be y pages

$$\text{Total number of pages} = 1382 \Rightarrow x + y = 1382 \rightarrow (1)$$

According problem

$$y = x + 64$$

$$x - y = -64 \rightarrow (2)$$

$$x + y = 1382$$

$$x - y = -64$$

$$2x = 1318$$

$$x = \frac{1318}{2} = 659$$

Substitute the value of x in (1) or (2)

$$x - y = -64$$

$$659 - y = -64$$

$$723 = y$$

∴ Number of pages in each part 659 and 723

7.A chemical has two solutions of hydrochloric acid in stock one is 50% solution and the other is 80% solution. How much of each should be used to obtain 100 ml of a 68% solution.

Sol: Let the first solution be x ml

Second solution be y ml

Total solution is 100ml

$$x + y = 100\text{ml} \rightarrow (1)$$

According to the problems

50% of solution + 80% of solution = 68

$$\frac{50}{100}x + \frac{80}{100}y = 68$$

$$5x + 8y = 680 \rightarrow (2)$$

$$(1) \times 5 \Rightarrow 5x + 5y = 500$$

$$5x + 8y = 680$$

$$+ 3y = + 180$$

$$y = 60$$

substitute the value of y in (1) or (2)

$$x + y = 100$$

$$x + 60 = 100 \Rightarrow x = 40$$

\therefore First and second solutions are 40 ml and 60ml.

www.sakshieducation.com

Essay Type Questions

1. A man travels 370 km partly by train and partly by car. If he covers 250 km by train and the rest by car, it takes him 4 hours. But if he travels 130 km by train and the rest by car, it takes 18 minutes more. Find the speed of the train and that of the car.

Sol: Let the speed of the train be x km/hour

Speed of the car be y km/hour

We know that $\text{time} = \frac{\text{speed}}{\text{distance}}$

Case (1) time spent travelling by train = $\frac{250}{x}$ hours

Time spent travelling by car = $\frac{120}{y}$ hours

Total time taken = $\frac{250}{x} + \frac{120}{y}$

But, total time of journey is 4 hours (given)

$$\frac{250}{x} + \frac{120}{y} = 4$$

$$\frac{125}{x} + \frac{60}{y} = 2 \longrightarrow (1)$$

Case(2): Time spent travelling by train = $\frac{130}{x}$ hours

Time spent travelling by car = $\frac{240}{y}$ hours

Total time taken = $\frac{130}{x} + \frac{240}{y}$

Time of journey is 4 hours 18 mts (given)

$$= \frac{130}{x} + \frac{240}{y} = 4 \frac{18}{60} = 4 \frac{3}{10} \text{ hours}$$

$$= \frac{130}{x} + \frac{240}{y} = \frac{43}{10} \longrightarrow (2)$$

$$\text{Let } \frac{1}{x} = a; \frac{1}{y} = b$$

$$125a + 60b = 2 \longrightarrow (3)$$

$$130a + 240b = \frac{43}{10} \longrightarrow (4)$$

$$(3) \times 4 \Rightarrow 500a + 240b = 8$$

$$130a + 240b = \frac{43}{10}$$

$$\begin{array}{r} - \quad - \quad - \\ \hline 370a \quad = 8 - \frac{43}{10} = \frac{37}{10} \end{array}$$

$$a = \frac{37}{10} \times \frac{1}{370} = \frac{1}{100}$$

Substitute the value of a in (3) or (4)

$$125a + 60b = 2$$

$$125 \times \frac{1}{100} + 60b = 2 \Rightarrow b = \frac{1}{80}$$

$$\text{So } a = \frac{1}{100}; b = \frac{1}{80}$$

$$a = \frac{1}{100} \Rightarrow \frac{1}{x} = \frac{1}{100} \Rightarrow x = 100 \text{ km / hour}$$

$$b = \frac{1}{80} \Rightarrow \frac{1}{y} = \frac{1}{80} \Rightarrow y = 80 \text{ km / hour}$$

Speed of train was 100 km/hour and

Speed of car was 80 km/hour

2. Solve: $\frac{5}{x-1} + \frac{1}{y-2} = 2$

$$\frac{6}{x-1} + \frac{3}{y-2} = 1$$

$$\frac{5}{x-1} + \frac{1}{y-2} = 2$$

Sol:

$$\frac{6}{x-1} + \frac{3}{y-2} = 1$$

Let $\frac{1}{x-1} = a; \frac{1}{y-2} = b$

$$5a + b = 2 \rightarrow (1)$$

$$6a - 3b = 1 \rightarrow (2)$$

$$(1) \times 3 \Rightarrow 15a + 3b = 6$$

$$\begin{array}{r} 6a - 3b = 1 \\ \hline 21a = 7 \end{array}$$

$$a = \frac{1}{3}$$

Substitute the value of a in (1) or (2)

$$5a + b = 2$$

$$5 \cdot \frac{1}{3} + b = 2 \Rightarrow b = \frac{1}{3}$$

$$a = \frac{1}{3} \Rightarrow \frac{1}{x-1} = \frac{1}{3} \Rightarrow x-1 = 3 \Rightarrow x = 4$$

$$b = \frac{1}{3} \Rightarrow \frac{1}{y-2} = \frac{1}{3} \Rightarrow y-2 = 3 \Rightarrow y = 5$$

3. $\frac{2}{\sqrt{x}} + \frac{3}{\sqrt{y}} = 2; \frac{4}{\sqrt{x}} - \frac{9}{\sqrt{y}} = -1$

Sol: $2\left(\frac{1}{\sqrt{x}}\right) + 3\left(\frac{1}{\sqrt{y}}\right) = 2$

$$4\left(\frac{1}{\sqrt{x}}\right) - 9\left(\frac{1}{\sqrt{y}}\right) = -1$$

Let $\frac{1}{\sqrt{x}} = a; \frac{1}{\sqrt{y}} = b$

$$2a + 3b = 2 \rightarrow (1)$$

$$4a - 9b = -1 \rightarrow (2)$$

$$(1) \times 2 \Rightarrow 4a + 6b = 4$$

$$\begin{array}{r}
 4a - 9b = -1 \\
 - \quad + \quad + \\
 \hline
 15b = 5
 \end{array}$$

$$b = \frac{5}{15} = \frac{1}{3}$$

Substitute the value of b in (1)

$$2a + 3b = 2$$

$$2a + 3 \cdot \frac{1}{3} = 2$$

$$2a + 1 = 2 \Rightarrow a = \frac{1}{2}$$

$$a = \frac{1}{2} \Rightarrow \frac{1}{\sqrt{x}} = \frac{1}{2} \Rightarrow \sqrt{x} = 2 \Rightarrow (\sqrt{x})^2 = 2^2 \Rightarrow x = 4$$

$$b = \frac{1}{3} \Rightarrow \frac{1}{\sqrt{y}} = \frac{1}{3} \Rightarrow \sqrt{y} = 3 \Rightarrow (\sqrt{y})^2 = 3^2 \Rightarrow y = 9$$

4. $6x + 3y = 6xy$

$2x + 4y = 5xy$

Sol: $6x + 3y = 6xy$

$$2x + 4y = 5xy$$

$$\frac{6x+3y}{xy} = 6$$

$$\frac{6}{y} + \frac{3}{x} = 6 \rightarrow (1)$$

$$\frac{2x+4y}{xy} = 5$$

$$\frac{2}{y} + \frac{4}{x} = 5 \rightarrow (2)$$

Let $\frac{1}{x} = a; \frac{1}{y} = b$

$$3a + 6b = 6 \rightarrow (3)$$

$$4a + 2b = 5 \rightarrow (4)$$

$$3a + 6b = 6$$

$$(4) \times 3 \Rightarrow 12a + 6b = 15$$

$$\begin{array}{r} - \quad - \quad - \\ \hline -9a = -9 \end{array}$$

$$a = 1$$

Substitute the value of a in (3) or (4)

$$3a + 6b = 6$$

$$3 \times 1 + 6b = 6$$

$$6b = 3, b = \frac{1}{2}$$

$$a = 1 \Rightarrow \frac{1}{x} = 1 \Rightarrow x = 1$$

$$b = \frac{1}{2} \Rightarrow \frac{1}{y} = \frac{1}{2} \Rightarrow y = 2$$

5. $\frac{10}{x+y} + \frac{2}{x-y} = 4$

$$\frac{15}{x+y} - \frac{5}{x-y} = -2$$

Sol: $\frac{10}{x+y} + \frac{2}{x-y} = 4$

$$\frac{15}{x+y} - \frac{5}{x-y} = -2$$

$$\text{Let } \frac{1}{x+y} = a; \frac{1}{x-y} = b$$

$$10a + 2b = 4 \rightarrow (1)$$

$$15a - 5b = -2 \rightarrow (2)$$

$$(1) \times 5 \Rightarrow 50a + 10b = 20$$

$$(2) \times 2 \Rightarrow 30a - 10b = -4$$

$$\frac{80a = 16}{}$$

$$a = \frac{16}{80} = \frac{1}{5}$$

Substitute the value of a in (1) or (2)

$$15a - 5b = -2$$

$$15. \frac{1}{5} - 5b = -2$$

$$3 - 5b = -2 \Rightarrow -5b = -5 \Rightarrow b = 1$$

$$a = \frac{1}{5} \Rightarrow \frac{1}{x+y} = \frac{1}{5} \Rightarrow x+y = 5$$

$$b = 1 \Rightarrow \frac{1}{x-y} = 1 \Rightarrow x-y = 1$$

$$x + y = 5 \quad \rightarrow (3)$$

$$x - y = 1 \quad \rightarrow (4)$$

$$\frac{2x = 6}{}$$

$$x = 3$$

Substitute the value of x in (3) or (4)

$$x + y = 5$$

$$3 + y = 5$$

$$y = 2$$

6.
$$\frac{1}{3x+y} + \frac{1}{3x-y} = \frac{3}{4}$$

$$\frac{1}{2(3x+y)} - \frac{1}{2(3x-y)} = -\frac{1}{8}$$

Sol: Let
$$\frac{1}{3x+y} = a; \frac{1}{3x-y} = b$$

$$a + b = \frac{3}{4}$$

$$\frac{a}{2} - \frac{b}{2} = -\frac{1}{8} \Rightarrow a - b = -\frac{1}{4}$$

$$a + b = \frac{3}{4} \rightarrow (1)$$

$$a - b = -\frac{1}{4} \rightarrow (2)$$

$$\begin{array}{r} 2a \\ \hline = \frac{3}{4} - \frac{1}{4} = \frac{2}{4} = \frac{1}{2} \end{array}$$

Substitute the value of a in (1) or (2)

$$a + b = \frac{3}{4}$$

$$\frac{1}{4} + b = \frac{3}{4}$$

$$b = \frac{3}{4} - \frac{1}{4} = \frac{2}{4} = \frac{1}{2}$$

$$a = \frac{1}{4} \Rightarrow \frac{1}{3x+y} = \frac{1}{4} \Rightarrow 3x + y = 4$$

$$b = \frac{1}{2} \Rightarrow \frac{1}{3x-y} = \frac{1}{2} \Rightarrow 3x - y = 2$$

$$3x + y = 4 \rightarrow (3)$$

$$3x - y = 2 \rightarrow (4)$$

$$\begin{array}{r} 6x \\ \hline = 6 \end{array}$$

$$x = 1$$

Substitute the value of x in (3) or (4)

$$3x + y = 4$$

$$3.1 + y = 4$$

$$y = 1$$

7. A boat goes 30 km upstream and 44 km downstream in 10 hours. In 13 hours it can go 40 km upstream and 55 km downstream. Determine the speed of the stream and that of the boat in still water?

Sol: Let the speed of the boat = x km/hour

The speed of the stream = y km /hour

Relative speed upstream = $(x - y)$ km/hour

Relative speed downstream = $(x + y)$ km/hour

Distance travelled to upstream = 30 km

$$\text{Time taken to up} = \frac{30}{x-y} \text{ hours}$$

Distance travelled to downstream = 44 km

$$\text{Time taken} = \frac{44}{x+y} \text{ hours}$$

$$\text{Total time taken} = \frac{30}{x-y} + \frac{44}{x+y}$$

Total time taken = 10 hours (Given)

$$\frac{30}{x-y} + \frac{44}{x+y} = 10 \longrightarrow (1)$$

Distance travelled to upstream = 40 km

$$\text{Time taken to up} = \frac{40}{x-y} \text{ hours}$$

Distance travelled to downstream = 55 km

$$\text{Time taken} = \frac{55}{x+y} \text{ hours}$$

Total time taken = 13 hours (Given)

$$\frac{40}{x-y} + \frac{55}{x+y} = 13 \longrightarrow (2)$$

$$\frac{30}{x-y} + \frac{44}{x+y} = 10$$

$$\frac{40}{x-y} + \frac{55}{x+y} = 13$$

$$\text{Let } \frac{1}{x-y} = a; \frac{1}{x+y} = b$$

$$30a + 44b = 10 \rightarrow (3)$$

$$40a + 55b = 13 \rightarrow (4)$$

$$(3) \times 4 \Rightarrow 120a + 176b = 40$$

$$(4) \times 3 \Rightarrow 120a + 165b = 39$$

$$\begin{array}{r} - \quad - \quad - \\ \hline 11b = 1 \Rightarrow b = \frac{1}{11} \end{array}$$

Substitute the value of b in (3) or (4)

$$30a + 44b = 10$$

$$30a + 44 \cdot \frac{1}{11} = 10$$

$$30a = 10 - 4 = 6 \Rightarrow a = \frac{1}{5}$$

$$a = \frac{1}{5} \Rightarrow \frac{1}{x-y} = \frac{1}{5} \Rightarrow x-y = 5$$

$$b = \frac{1}{11} \Rightarrow \frac{1}{x+y} = \frac{1}{11} \Rightarrow x+y = 11$$

$$x - y = 5 \rightarrow (5)$$

$$x + y = 11 \rightarrow (6)$$

$$\begin{array}{r} \hline 2x = 16 \end{array}$$

$$x = 8$$

substitute the value of x in (5) or (6)

$$x + y = 11$$

$$8 + y = 11 \Rightarrow y = 3$$

\therefore Speed of the boat = 8km/hour

Speed of the stream = 3km/hour

8.2 women and 5 men can together finish an embroidery work in 4 days while 3 women and 6 man can finish it in 3 days. Find the time taken by 1 women alone and 1 man alone to finish the work.

Sol: Let the time taken by one women to finish the work = x days

$$\text{Work done by one women in one day} = \frac{1}{x}$$

Let the time taken by are men to finish the work = y days

$$\text{Work done by one man in one day} = \frac{1}{y}$$

According to the problem

2 women and 5 men can together finish an embroidery work in 4 days.

$$\text{Work done by 2 women and 5 man in one day} = \frac{1}{4}$$

$$\text{So work done by 2 women in one day} = 2 \times \frac{1}{x} = \frac{2}{x}$$

$$\text{Work done by 5 men in one day} = 5 \times \frac{1}{y} = \frac{5}{y}$$

$$\text{Total work} = \frac{2}{x} + \frac{5}{y}$$

$$= \frac{2}{x} + \frac{5}{y} = \frac{1}{4} \longrightarrow (1)$$

Also 3 women and 6men can finish the work in 3 days

Work done by 3 women and 6 men in one day

$$= \frac{3}{x} + \frac{6}{y} = \frac{1}{3} \longrightarrow (2)$$

$$\frac{1}{x} = a; \frac{1}{y} = b$$

$$2a + 5b = \frac{1}{4} \longrightarrow (2)$$

$$3a + 6b = \frac{1}{3} \longrightarrow (4)$$

$$(3) \times 3 \Rightarrow 6a + 15b = \frac{3}{4}$$

$$(4) \times 2 \Rightarrow 6a + 12b = \frac{2}{3}$$

$$\begin{array}{r} - \quad - \quad - \\ \hline 3b = \frac{3}{4} - \frac{2}{3} = \frac{9-8}{12} = \frac{1}{12} \end{array}$$

$$b = \frac{1}{36}$$

Substitute 1 value of b in (3) or (4)

$$2a + 5b = \frac{1}{4}$$

$$2a + 5 \cdot \frac{1}{36} = \frac{1}{4}$$

$$2a = \frac{1}{4} - \frac{5}{36} = \frac{9-5}{36} = \frac{4}{36}$$

$$a = \frac{4}{36} \times \frac{1}{2} = \frac{1}{18}$$

$$a = \frac{1}{18} \Rightarrow \frac{1}{x} = \frac{1}{18} \Rightarrow x = 18$$

$$b = \frac{1}{36} \Rightarrow \frac{1}{y} = \frac{1}{36} \Rightarrow y = 36$$

Time taken by one women to finish the work = 18days

Time taken by one men to finish the work = 36 days.

Graphical method of finding solution of a pair of linear equations

1.10 students of class – X took part in a maths quiz. If the number of girls is 4 more than number of boys then find the number of boys and the number of girls who took part in the quiz.

Sol: Let the number of boys = x

The number of girls = y

Total number of students took part in maths quiz = 10

$$x + y = 10 \rightarrow (1)$$

if the number of girls is 4 more than no.of boys $y = x + 4$

$$x - y = -4 \rightarrow (1)$$

$$x + y = 10$$

$$y = 10 - x$$

x	$y = 10 - x$	(x, y)
0	$y = 10$	(0, 10)
2	$y = 8$	(2, 8)
4	$y = 6$	(4, 6)
6	$y = 4$	(6, 4)

$$x - y = -4$$

$$y = x + 4$$

x	y	(x, y)
0	4	(0, 4)
2	6	(2, 6)
4	8	(4, 8)
6	10	(6, 10)

\therefore Number of boys = 3

Number of girls = 7

1

Scale

x-axis 1 unit = 1cm

y-axis 1 unit = 2cm

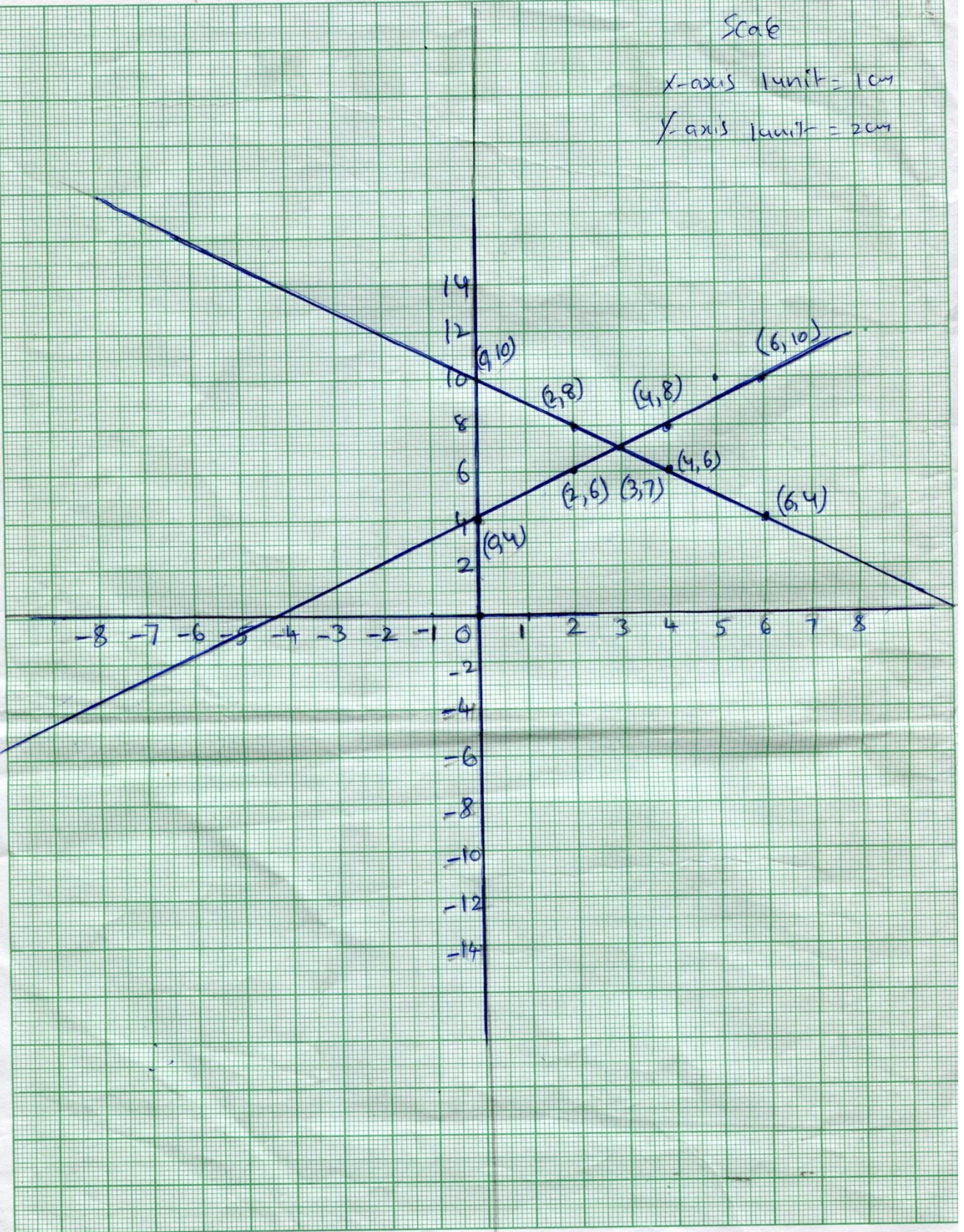

2.5 pencils and 7 pens together cost Rs 50. Where as 7 pencils and 5 pen together cost Rs. 46. Find the cost of one pencils and one pen?

Sol: Cost of one pencil is Rs x

Cost of one pen is Rs y

5 pencils and 7 pens together cost = Rs50

$$5x + 7y = 50 \rightarrow (1)$$

7 pencils and 5 pens together cost = Rs. 46

$$7x + 5y = Rs\ 46 \rightarrow (2)$$

$$5x + 7y = 50$$

$$y = \frac{50 - 5x}{7}$$

x	y	(x, y)
0	$\frac{50}{7} = 7.1$	(0, 7.1)
1	$\frac{45}{7} = 6.5$	(1, 6.5)
2	$\frac{40}{7} = 5.7$	(2, 5.7)

$$7x + 5y = 46$$

$$y = \frac{46 - 7x}{5}$$

x	y	(x, y)
0	9.2	(0, 9.2)
1	7.8	(1, 7.8)
2	6.2	(2, 6.2)

Cost of a pencil = Rs 3.

Cost of a pen = Rs 5.

2

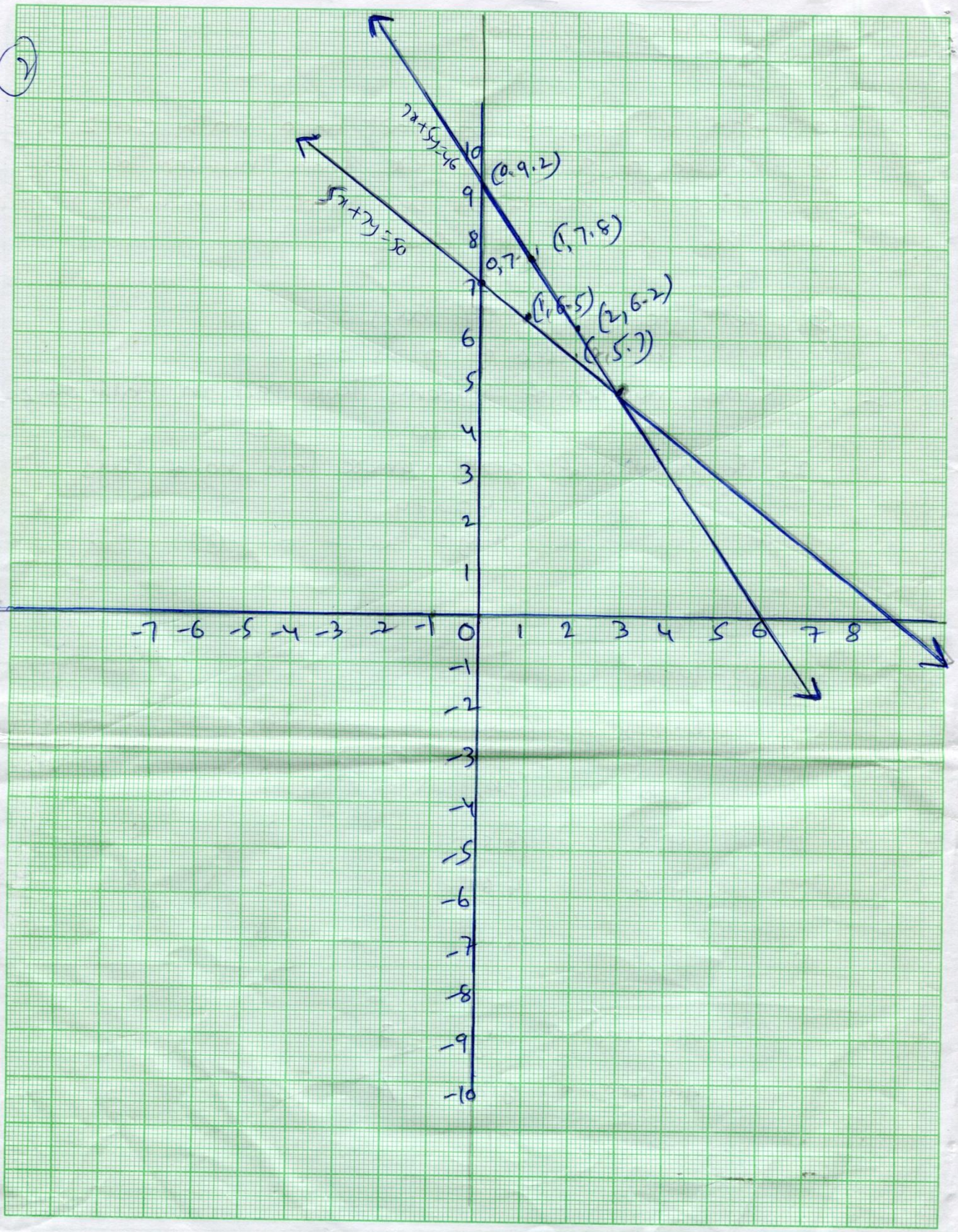

3. The perimeter of a rectangular plot is 32m. If the length is increased by 2m and the breadth is decreased by 1m. The area of the plot remains the same. Find the length and breadth of the plot.

Sol: Let the length and breadth of Rectangular plot is l and b m.

$$\text{Area of rectangle} = lb \text{ units}$$

$$\text{Perimeter} = 2(l + b) = 32$$

When length is increased by 2m and the breadth is decreased by 1m. Then

$$\text{area} = (l + 2)(b - 1)$$

Since there is no change in the area

$$(l + 2)(b - 1) = lb$$

$$l - 2b + 2 = 0 \rightarrow (2)$$

$$l + b - 16 = 0$$

l	b	(l, b)
6	10	(6, 10)
8	8	(8, 8)
10	6	(10, 6)
12	4	(12, 4)
14	2	(14, 2)

$$l - 2b + 2 = 0$$

l	b	(l, b)
6	4	(6, 4)
8	5	(8, 5)
10	6	(10, 6)
12	7	(12, 7)
14	8	(14, 8)

3

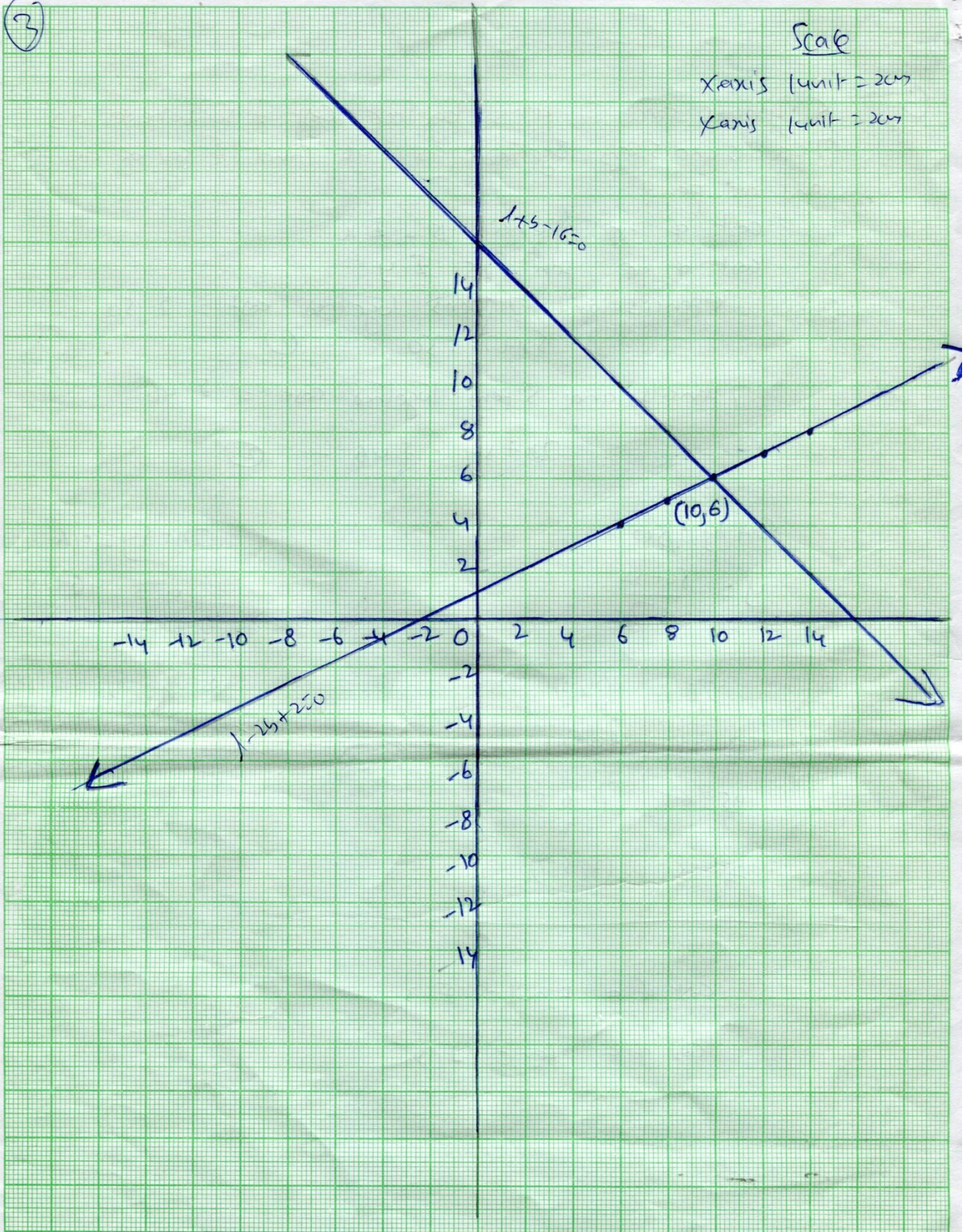

Fill in the blanks:

- 1) An equation of the form $ax+by+c=0$ where a,b,c are real numbers and where atleast one of a or b is not zero is called equation.
- 2) The general form of linear equation is
- 3) A linear equation in two variables has solutions.
- 4) The graph of a linear equation in two variables is a
- 5) Two lines are drawn in the same plane , then the lines may intersect at point.
- 6) The graph of a pair of linear equations in two variables then the lines intersect at a one point gives the solution of the equations.
- 7) If the lines coincide then they are solutions.
- 8) If the lines are parallel then the pair of equations has solutions.
- 9) $3x+2y=5, 2x-3y=7$ then the pair of linear equations is
- 10) $2x-3y=8, 4x-6y=9$ then the pair of linear equations is
- 11) Sum of the complimentary angles is
- 12) Sum of the supplementary angles is
- 13) Time=.....
- 14) The value of x in the equation $2x-(4-x)=5-x$ is
- 15) The equation $x-4y=5$ has solutions.
- 16) The sum of two numbers is 80 and their ratio is 3:5 then the first number is
- 17) The value of x in the equation $5x-8=2x-2$ is
- 18) For what value of P the following pair of equations has unique solution $2x+py=-5, 3x+3y=-6$ is
- 19) A system of two linear equations in two variables is said to be constant if it has at least solutions.
- 20) No of solutions for the equation $3(7-3y)+4y=16$ is.....
- 21) A system of linear equations in two variables is said to be inconsistent if it has solutions.

- 22) When two lines in the same plane may intersect is.....
- 23) $3x+2y-80=0$, $4x+3y-110=0$ solution for this linear equation is
- 24) $X+2y-30=0$, $2x+4y-66=0$ these lines represent
- 25) $4x+9y-13=0$ no of unknowns in this linear equation is
- 26) In the equation $4x+3y-4=0$ then $a=.....$, $c=.....$
- 27) Sum of two numbers is 44 then the equation form is
- 28) $4x-2y=0$, $2x-3y=0$ then $a_1=.....$, $c_1=.....$
- 29) The difference of two numbers is 48 then the equation is _____
- 30) A_____ in two variables can be solved using various methods.

ANSWERS

- | | | | | |
|-----------------------------|-------------------|-------------------|-----------------|-----------------------------|
| 1.Linear | 2. $ax+by+c=0$ | 3.Many | 4.Straight line | 5.one |
| 6.Unique | 7.Infinetely | 8.No | 9.Consistent | 10.Inconsistent |
| 11. 90^0 | 12. 180^0 | 13.Distance/speed | | 14.9/4 |
| 15.Infinetly many solutions | | 16.30 | 17. $x=2$ | 18. $P=3$ |
| 19.One | 20.Unique | 21.NO | | 22.Onepoint |
| 23.Unique | 24.Parallel lines | 25.Two | | 26.4,-4 |
| 27. $x+y=44$ | 28.4,0 | 29. $x-y=48$ | | 30.pair of linear equations |

CHAPTER - 5

QUADRATIC EQUATIONS

Quadratic Equations: A quadratic equation in the variable x is an equation of the form $ax^2 + bx + c = 0$ where a, b, c are real numbers and $a \neq 0$

(Or)

Any equation of the form $P(x) = 0$ Where $P(x)$ is polynomial of degree 2 is a quadratic equation.

$ax^2 + bx + c = 0$ is called the standard form of the quadratic equation

$y = ax^2 + bx + c$ is called quadratic function

There are various uses of quadratic functions. Some of them are:

- i. When the rocket is fired upward then the height of the rocket is defined by a '**Quadratic Function**'.
- ii. Shapes of the satellite, reflecting mirror in a telescope lens of the eye glasses and orbit of the celestial objects are defined by the quadratic equation
- iii. The part of the projectile is defined by quadratic function.
- iv. When the breaks are applied to a vehicle, then the stopping point is calculated by using quadratic equation

A real number α is called a root of a quadratic equation $ax^2 + bx + c = 0$ if

$a\alpha^2 + b\alpha + c = 0$ we also say that $x = \alpha$ is a solution of the quadratic equation. or α satisfies the quadratic equation.

Ex: 2, 3 are roots of the quadratic equation $x^2 - 5x + 6 = 0$

The zeroes of the quadratic polynomial $ax^2 + bx + c$ and the roots of the quadratic equation $ax^2 + bx + c = 0$ are the same.

Any quadratic equation can have at most two roots.

Solution of a Quadratic Equation By Factorisation

If the quadratic equation $ax^2 + bx + c = 0$ can be written in the form

$(px + q)(rx + s) = 0$; $p \neq 0, r \neq 0$ then $-\frac{q}{p}$ and $-\frac{s}{r}$ will be the root of quadratic equation. Which are respectively the values of x obtained from $px + q = 0$ and $rx + s = 0$

Ex: $6x^2 - x - 2 = 0$

$$\Rightarrow (3x - 2)(2x + 1) = 0$$

The roots of $6x^2 - x - 2 = 0$ are the values of “ x ” for which

$$\Rightarrow (3x - 2)(2x + 1) = 0$$

$$\Rightarrow 3x - 2 = 0 \text{ or } 2x + 1 = 0$$

i.e $x = \frac{2}{3}$ or $x = -\frac{1}{2}$

\therefore The roots of $6x^2 - x - 2 = 0$ are $\frac{2}{3}$ and $-\frac{1}{2}$

To factorize a quadratic equation $ax^2 + bx + c = 0$ we find $p, q \in \mathbb{R}$ such that $p + q = b$ and $pq = ac$.

This process is called Factorising a quadratic equation by splitting its middle term.

Solution of a Quadratic Equation By Completing The Square

Let the quadratic equation be $ax^2 + bx + c = 0$, $a \neq 0$

Dividing throughout by a , we get

$$x^2 + \frac{b}{a}x + \frac{c}{a} = 0$$

Adding and Subtracting $\left(\frac{b}{2a}\right)^2$

$$x^2 + \frac{b}{a}x + \left(\frac{b}{2a}\right)^2 - \left(\frac{b}{2a}\right)^2 + \frac{c}{a} = 0$$

$$\left(x + \frac{b}{2a}\right)^2 - \frac{(b^2 - 4ac)}{4a^2} = 0$$

$$\left(x + \frac{b}{2a}\right)^2 = \frac{(b^2 - 4ac)}{4a^2}$$

$$x + \frac{b}{2a} = \frac{\pm\sqrt{b^2 - 4ac}}{2a}$$

$$x = \frac{-b \pm \sqrt{b^2 - 4ac}}{2a}$$

Thus if $b^2 - 4ac \geq 0$ then the roots of the quadratic equation $ax^2 + bx + c = 0$

are given by $\frac{-b \pm \sqrt{b^2 - 4ac}}{2a}$

Let $ax^2 + bx + c = 0$, $a \neq 0$ be a quadratic equation then $b^2 - 4ac$ is called the Discriminate of the quadratic equation.

If $b^2 - 4ac > 0$ then the roots of the quadratic equation $ax^2 + bx + c = 0$ are

given by $x = \frac{-b \pm \sqrt{b^2 - 4ac}}{2a}$

This is called quadratic formula to find the roots.

A quadratic equation $ax^2 + bx + c = 0$ has

- i. Two distinct real roots, if $b^2 - 4ac > 0$
- ii. Two equal real roots, if $b^2 - 4ac = 0$
- iii. No real roots, if $b^2 - 4ac < 0$

Roots of a quadratic equation are those points where the curve cuts the X-axis.

Case - 1: If $b^2 - 4ac > 0$

We get two distinct real roots $\frac{-b - \sqrt{b^2 - 4ac}}{2a}$, $\frac{-b + \sqrt{b^2 - 4ac}}{2a}$

In such case we get the following figures.

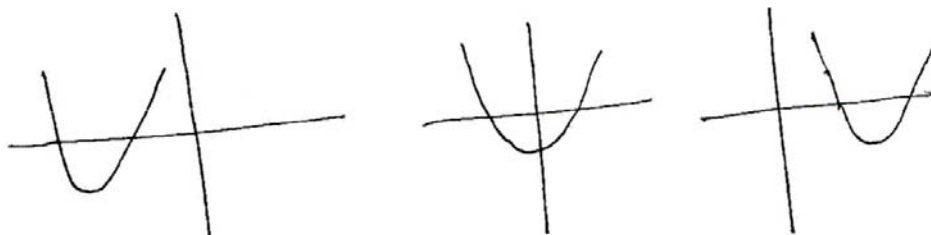

Figure shows that the curve of the quadratic equation cuts the X-axis at two distinct points.

Case - 2 : If $b^2 - 4ac = 0$

$$x = \frac{-b \pm 0}{2a}; x = \frac{-b}{2a}, \frac{-b}{2a}$$

In such case we get the following figures.



Figure shows that the curve of the quadratic equation touching X-axis at one point.

Case - 3 : If $b^2 - 4ac < 0$

There are no real roots. Roots are imaginary. In such case we get the following figures.

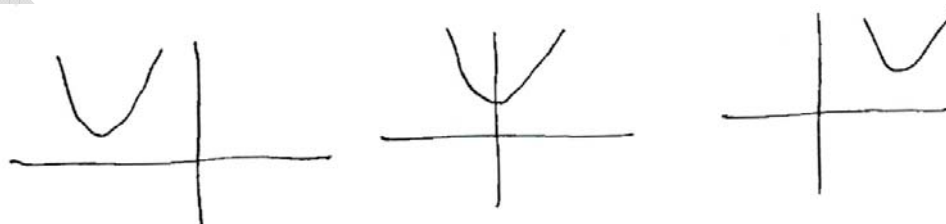

In this case graph neither intersects nor touches the X-axis at all. So there are no real roots.

Let $ax^2 + bx + c = 0$ be a given quadratic equation and α, β are the roots of given quadratic equation, then

$$\text{Sum of the roots} = \alpha + \beta = \frac{-b}{a} = \frac{-x \text{ Coefficient}}{x^2 \text{ Coefficient}}$$

$$\text{Product of the roots} = \alpha \beta = \frac{c}{a} = \frac{\text{Constant term}}{x^2 \text{ Coefficient}}$$

Quadratic equation whose roots are α, β is $x^2 - (\alpha + \beta)x + \alpha\beta = 0$

ESSAY EQUATIONS

1) Find the roots of the following quadratic equations by factorization

$$(i) x - \frac{1}{3x} = \frac{1}{6}$$

$$(ii) 3(x - 4)^2 - 5(x - 4) = 12$$

Sol:

$$(i) x - \frac{1}{3x} = \frac{1}{6}$$

$$\Rightarrow x - \frac{1}{3x} - \frac{1}{6} = 0 \Rightarrow \frac{18x^2 - 6 - 3x}{18x} = 0$$

$$18x^2 - 3x - 6 = 0$$

$$\Rightarrow 3(6x^2 - x - 2) = 0 \Rightarrow 6x^2 - x - 2 = 0$$

$$\Rightarrow 2x(3x - 2) + 1(3x - 2) = 0$$

$$\Rightarrow (3x - 2)(2x + 1) = 0$$

$$\Rightarrow 3x - 2 = 0 \text{ (or) } 2x + 1 = 0$$

$$\Rightarrow x = \frac{2}{3} \text{ (or) } x = -\frac{1}{2}$$

\therefore The roots of given quadratic equation are $\frac{2}{3}, -\frac{1}{2}$

$$(ii) 3(x - 4)^2 - 5(x - 4) = 12$$

$$\Rightarrow \text{Let } x - 4 = a$$

$$\Rightarrow 3a^2 - 9a + 4a - 12 = 0 \text{ } (\because 3 \times -12 = -36)$$

$$\Rightarrow 3a(a - 3) + 4(a - 3) = 0$$

$$\Rightarrow (a - 3)(3a + 4) = 0$$

$$\Rightarrow a = 3 \text{ (or) } a = -\frac{4}{3}$$

$$\Rightarrow \text{But } a = x - 4$$

$$\text{i.e. } x - 4 = 3 \Rightarrow x = 7$$

$$x - 4 = -\frac{4}{3} \Rightarrow x = -\frac{4}{3} + 4$$

$$\Rightarrow x = \frac{-4 + 12}{3} = \frac{8}{3}$$

The roots of given quadratic equation are $7, \frac{8}{3}$

2) Find two consecutive positive integers, sum of whose squares is 613.

Sol: Let the two consecutive positive integers be $x, x+1$

Given that sum of the squares of two consecutive integers is 613.

$$\text{i.e. } x^2 + (x + 1)^2 = 613$$

$$\Rightarrow x^2 + x^2 + 2x + 1 = 613$$

$$\Rightarrow 2x^2 + 2x + 1 - 613 = 0$$

$$\Rightarrow 2x^2 + 2x - 612 = 0$$

$$\Rightarrow 2(x^2 + x - 306) = 0 \Rightarrow x^2 + x - 306 = 0$$

$$(\because 1 \times -306 = -306 \text{ (} 18 \times -17 \text{)})$$

$$\Rightarrow x^2 + 18x - 17x - 306 = 0$$

$$\Rightarrow x(x + 18) - 17(x + 18) = 0$$

$$\Rightarrow (x + 18)(x - 17) = 0$$

$$\Rightarrow (x + 18) = 0 \text{ (or) } x - 17 = 0$$

$$\Rightarrow x = -18 \text{ (or) } x = 17$$

If x is positive, then $x = 17$.

If $x = 17$ then the consecutive positive integers are 17, 18.

3) The altitude of a right triangle is 7cm less than its base. If the hypotenuse is 13 cm; find the other two sides?

Sol: Let the base of a right angle triangle be 'x'.

Given that the altitude of a right triangle is 7 cm less than its base.

$$\text{Altitude (or) height} = h = x - 7$$

Given that hypotenuse = 13 cm

By pythagorus theorem

$$(\text{Hypotenuse})^2 = (\text{Base})^2 + (\text{Height})^2 \Rightarrow x^2 - 12x + 5x - 60 = 0$$

$$\Rightarrow (13)^2 = x^2 + (x - 7)^2$$

$$\Rightarrow x^2 + x^2 - 14x + 49 = 169$$

$$\Rightarrow 2x^2 - 14x - 120 = 0$$

$$\Rightarrow 2(x^2 - 7x - 60) = 0, \Rightarrow x^2 - 7x - 60 = 0$$

$$\Rightarrow x^2 - 12x + 5x - 60 = 0$$

$$\Rightarrow x(x - 12) + 5(x - 12) = 0$$

$$\Rightarrow (x - 12)(x + 5) = 0$$

$$\Rightarrow x = 12, -5$$

Length of base is always positive.

Length of base = 12 cm

Height (or) Altitude = $x - 7 = 12 - 7 = 5$ cm

- 4) **A cottage industry produces a certain number of pottery articles in a day. It was observed on a particular day that the cost of production of each article (in rupees) was 3 more than twice the number of articles produced on that day. If the total cost of production on that day was Rs. 90, find the number of articles produced and the cost of each article.**

Sol: Let the number of pottery articles produced by a cottage industry be 'x'.

Given that the cost of production of each article (in rupees) was 3 more than twice the number of articles produced on that day.

$$\therefore \text{Price of each article} = 2x + 3$$

$$\text{Total cost of articles} = \text{Rs. } 90$$

$$\text{i.e. } x(2x + 3) = 90 \Rightarrow 2x^2 + 3x - 90 = 0$$

$$\Rightarrow 2x^2 + 15x - 12x - 90 = 0$$

$$\Rightarrow x(2x + 15) - 6(2x + 15) = 0$$

$$\Rightarrow (x - 6)(2x + 15) = 0$$

$$\Rightarrow 2x + 15 = 0 \text{ (or) } x - 6 = 0$$

$$\Rightarrow x = -\frac{15}{2} \text{ (or) } x = 6$$

No of articles never be negative, So $x \neq -\frac{15}{2}$

$$\text{Price of each article} = 2x + 3 = 2(6) + 3 = \text{Rs. } 15$$

5) Find the dimensions of a rectangle whose perimeter is 28 meters and whose area is 40 square meters.

Sol: Let the length of a rectangle be 'x' meters i.e $l = x$

$$\text{Perimeter of a rectangle} = 2(l + b) = 28\text{m (Given)}$$

$$\Rightarrow 2(x + b) = 28 \Rightarrow x + b = 14 \Rightarrow b = 14 - x$$

Given that area of a rectangle = lb

$$\Rightarrow x(14 - x) = 40 \text{ sq.m}$$

$$\Rightarrow 14x - x^2 = 40$$

$$\Rightarrow 14x - x^2 - 40 = 0$$

$$\Rightarrow x^2 - 14x + 40 = 0$$

$$\Rightarrow x^2 - 10x - 4x + 40 = 0$$

$$\Rightarrow x(x - 10) - 4(x - 10) = 0$$

$$\Rightarrow (x - 10)(x - 4) = 0$$

$$\Rightarrow x = 10 \text{ (or) } x = 4$$

If the length $x = 10\text{m}$, then the width $b = 14 - x = 14 - 10 = 4 \text{ m}$

If the length $x = 4 \text{ cm}$, then width $b = 14 - x = 14 - 4 = 10 \text{ m}$

The dimensions of rectangle are 10m, 4m.

- 6) **The base of a triangle is 4 cm, longer than its altitude. If the area of the triangle is 48 sq. cm then find its base and altitude.**

Sol: Let the height of the triangle = x cm

Given that the base of a triangle is 4 cm, longer than its altitude (height)

i.e Base = $(x + 4)$ cm

$$\text{Area of the triangle} = \frac{1}{2}bh = 48 \text{ sq.cm}$$

$$\Rightarrow \frac{1}{2} \times (x + 4) x = 48$$

$$\Rightarrow x^2 + 4x = 96$$

$$\Rightarrow x^2 + 4x - 96 = 0$$

$$\Rightarrow x^2 + 12x - 8x - 96 = 0$$

$$\Rightarrow x(x + 12) - 8(x + 12) = 0$$

$$\Rightarrow (x + 12)(x - 8) = 0$$

$$x + 12 = 0 \text{ (or) } x - 8 = 0$$

$$x = -12 \text{ (or) } x = 8$$

Height of the triangle never be negative.

Height $x = 8$ cm

Base = $x + 4 = 8 + 4 = 12$ cm

- 7) Two trains leave a railway station at the same time. The first train travels towards West and the second train towards north. The first train travels 5km/hr faster than the second train. If after two hours they are 50 km apart. Find average speed of each train?

Sol: Let the speed of second train = x km/hour

Speed of first train = $x + 5$ km/hour

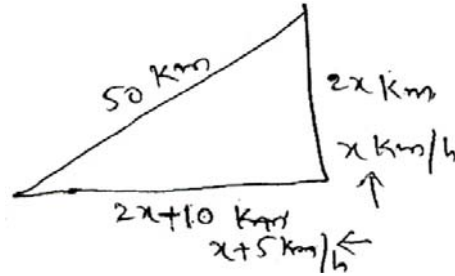

After two hours distance travelled by first train = $2(x + 5) = 2x + 10$ km

Distance travelled by second train = $2x$ km.

Distance between two trains after two hours = 50 km

By pythagoras theorem

$$(2x + 10)^2 + (2x)^2 = 50^2$$

$$\Rightarrow 4x^2 + 40x + 100 + 4x^2 = 2500$$

$$8x^2 + 40x - 2400 = 0 \Rightarrow 8(x^2 + 5x - 300) = 0$$

$$\Rightarrow x^2 + 20x - 15x - 300 = 0$$

$$\Rightarrow x(x + 20) - 15(x + 20) = 0$$

$$\Rightarrow (x + 20)(x - 15) = 0$$

$$\Rightarrow x = -20, x = 15$$

Speed of the train never be negative

Speed of second train = 15 km/hour

Speed of first train = $x + 5 = 15 + 5 = 20$ km/hour

- 8) **In a class of 60 students, each boy contributed rupees equal to the number of girls and each girl contributes rupees equal to the number of boys. If the total money then collected was Rs. 1600. How many boys are there in the class?**

Sol: Total number of students in a class = 60

Let the number of boys = x

Then the number of girls = $60 - x$

Each boy contributed rupees equal to the number of girls and each girl contributed rupees equal to the number of boys and the total money collected was Rs. 1600.

$$\text{i.e } x(60 - x) + x(60 - x) = 1600$$

$$\Rightarrow 2x(60 - x) = 1600$$

$$\Rightarrow x(60 - x) = 800$$

$$\Rightarrow 60x - x^2 - 800 = 0$$

$$\Rightarrow x^2 - 60x + 800 = 0$$

$$\Rightarrow x^2 - 20x - 40x + 800 = 0$$

$$\Rightarrow x(x - 20) - 40(x - 20) = 0$$

$$\Rightarrow (x - 20)(x - 40) = 0$$

$$\Rightarrow x = 20 \text{ (or) } x = 40$$

Number of boys in the class room = 20 or 40

- 9) **A motor boat heads upstream a distance of 24km on a river whose current is running at 3km per hour. The trip up and back takes 6 hours. Assuming that the motor boat maintained a constant speed, what is its speed?**

Sol: Let the speed of a motor boat = x km/hr

Speed of stream = 3 km/hour

The distance of the river = 24 km

The speed of the boat in upstream = $(x - 3)$ km/h

The speed of the boat in downstream = $x + 3$ km/h

Given that total time taken = 6 hours

$$\text{i.e. } \frac{24}{x + 3} + \frac{24}{x - 3} = 6$$

$$\Rightarrow 24(x - 3) + 24(x + 3) = 6(x + 3)(x - 3)$$

$$6[4(x - 3) + 4(x + 3)] = 6(x + 3)(x - 3)$$

$$4x - 12 + 4x + 12 = x^2 - 9$$

$$x^2 - 8x - 9 = 0$$

$$\Rightarrow x^2 - 9x + x - 9 = 0$$

$$\Rightarrow x(x - 9) + 1(x - 9) = 0$$

$$\Rightarrow (x - 9)(x + 1) = 0$$

$$\Rightarrow x = 9, x = -1$$

Speed of the boat never be negative.

Speed of boat in still water = 9 km/hour.

10) Solve the equations by completing the square.

i. $5x^2 - 7x - 6 = 0$

ii. $4x^2 + 4\sqrt{3}x + 3 = 0$

Sol: (i) Given quadratic equation $5x^2 - 7x - 6 = 0$, dividing with 5 on both sides.

$$x^2 - \frac{7}{5}x - \frac{6}{5} = 0$$

$$\Rightarrow x^2 - \frac{7}{5}x = \frac{6}{5}$$

$$\Rightarrow x^2 - 2(x)\left(\frac{7}{10}\right) = \frac{6}{5} \left(\because 2\left(\frac{7}{10}\right) = \frac{7}{5}\right)$$

Adding $\left(\frac{7}{10}\right)^2$, on both sides

$$\Rightarrow x^2 - 2(x)\left(\frac{7}{10}\right) + \left(\frac{7}{10}\right)^2 = \frac{6}{5} + \left(\frac{7}{10}\right)^2$$

$$\Rightarrow \left(x - \frac{7}{10}\right)^2 = \frac{6}{5} + \frac{49}{100} \left(\because x^2 - 2xy + y^2 = (x - y)^2\right)$$

$$\Rightarrow \left(x - \frac{7}{10}\right)^2 = \frac{120 + 49}{100} = \frac{169}{100}$$

$$\Rightarrow \left(x - \frac{7}{10}\right)^2 = \left(\frac{13}{10}\right)^2$$

$$\Rightarrow x - \frac{7}{10} = \pm \frac{13}{10} \left(\because x^2 = a^2 \Rightarrow x = \pm a\right)$$

$$\Rightarrow x = \pm \frac{13}{10} + \frac{7}{10}$$

$$= \frac{13}{10} + \frac{7}{10} \text{ (or) } -\frac{13}{10} + \frac{7}{10}$$

$$= \frac{20}{10} \text{ (or) } \frac{-6}{10} = 2 \text{ (or) } -\frac{3}{5}$$

(ii) Given quadratic equation $4x^2 + 4\sqrt{3}x + 3 = 0$

Dividing on both sides by 4, we get $x^2 + \sqrt{3}x + \frac{3}{4} = 0$

$$\Rightarrow x^2 + \sqrt{3}x = -\frac{3}{4}$$

$$\Rightarrow x^2 + 2(x)\left(\frac{\sqrt{3}}{2}\right) = -\frac{3}{4} \left(\because \sqrt{3} = 2\left(\frac{\sqrt{3}}{2}\right)\right)$$

Adding $\left(\frac{\sqrt{3}}{2}\right)^2$ on both sides, we get Adding $\left(\frac{\sqrt{3}}{2}\right)^2$ on both sides, we get

$$\Rightarrow x^2 + 2(x)\left(\frac{\sqrt{3}}{2}\right) + \left(\frac{\sqrt{3}}{2}\right)^2 = -\frac{3}{4} + \left(\frac{\sqrt{3}}{2}\right)^2 = -\frac{3}{4} + \frac{3}{4}$$

$$\Rightarrow \left(x + \frac{\sqrt{3}}{2}\right)^2 = 0$$

$$\Rightarrow x + \frac{\sqrt{3}}{2} = 0 \Rightarrow x = -\frac{\sqrt{3}}{2}$$

11) Find the roots of the following quadratic equations, if they exist, using the quadratic formula.

i. $2x^2 - 2\sqrt{2}x + 1 = 0$

ii. $x + \frac{1}{x} = 3 \ (x \neq 0)$

Sol:

(i) Given quadratic equation $2x^2 - 2\sqrt{2}x + 1 = 0$

Compare $ax^2 + bx + c = 0$; $a = 2$, $b = -2\sqrt{2}$, $c = 1$

$$\text{So, } b^2 - 4ac = (-2\sqrt{2})^2 - 4(2)(1) = 8 - 8 = 0$$

Since $b^2 - 4ac \geq 0$, the roots are exist.

$$\therefore x = \frac{-b \pm \sqrt{b^2 - 4ac}}{2a} = \frac{-(-2\sqrt{2}) \pm \sqrt{0}}{2(2)} = \frac{2\sqrt{2}}{4} = \frac{\sqrt{2}}{2} = \frac{1}{\sqrt{2}}$$

So the roots are $\frac{1}{\sqrt{2}}$, $\frac{1}{\sqrt{2}}$

(ii)

$$\text{Given that } x + \frac{1}{x} = 3$$

$$\Rightarrow \frac{x^2 + 1}{x} = 3 \Rightarrow x^2 + 1 = 3x \Rightarrow x^2 - 3x + 1 = 0$$

Compare with $ax^2 + bx + c = 0$, we get $a = 1$, $b = -3$, $c = 1$

$$b^2 - 4ac = (-3)^2 - 4(1)(1) = 9 - 4 = 5$$

$$\therefore x = \frac{-b \pm \sqrt{b^2 - 4ac}}{2a} = \frac{-(-3) \pm \sqrt{(-3)^2 - 4(1)(1)}}{2(1)}$$

$$x = \frac{3 \pm \sqrt{9 - 4}}{2} = \frac{3 \pm \sqrt{5}}{2}$$

So the roots are $\frac{3 + \sqrt{5}}{2}$ and $\frac{3 - \sqrt{5}}{2}$

12) Find the roots of the following quadratic equations?

i. $\frac{1}{x} - \frac{1}{x-2} = 3, (x \neq 0, 2)$

ii. $\frac{1}{x+4} - \frac{1}{x-7} = \frac{11}{30}, (x \neq -4, 7)$

Sol:

(i) Given $\frac{1}{x} - \frac{1}{x-2} = 3$

Multiplying the equation by $x(x-2)$ we get

$$(x-2) - x = 3x(x-2)$$

$$\Rightarrow 3x(x-2) = -2$$

$$3x^2 - 6x = -2 \Rightarrow 3x^2 - 6x + 2 = 0$$

Which is a quadratic equation compare with $ax^2 + bx + c = 0$

$$a = 3, b = -6, c = 2$$

$$\text{So, } b^2 - 4ac = (-6)^2 - 4(3)(2) = 36 - 24 = 12 > 0$$

$$\therefore x = \frac{-b \pm \sqrt{b^2 - 4ac}}{2a} = \frac{-(-6) \pm \sqrt{12}}{2(3)}$$

$$x = \frac{6 \pm 2\sqrt{3}}{6} = \frac{2(3 \pm \sqrt{3})}{6} = \frac{(3 \pm \sqrt{3})}{3}$$

$$\text{So the roots are } \frac{3+\sqrt{3}}{3} \text{ and } \frac{3-\sqrt{3}}{3}$$

(ii) Given $\frac{1}{x+4} - \frac{1}{x-7} = \frac{11}{30}$, ($x \neq -4, 7$)

Multiplying the equation by $30(x+4)(x-7)$, we get

$$30(x-7) - 30(x+4) = 11(x+4)(x-7)$$

$$\Rightarrow 30x - 210 - 30x - 120 = 11(x^2 - 7x + 4x - 28)$$

$$\Rightarrow -330 = 11(x^2 - 3x - 28)$$

$$\Rightarrow x^2 - 3x - 28 + 30 = 0$$

$$\Rightarrow x^2 - 3x + 2 = 0$$

$$\Rightarrow x^2 - 2x - x + 2 = 0$$

$$\Rightarrow x(x-2) - 1(x-2) = 0$$

$$\Rightarrow (x-2)(x-1) = 0$$

$$\Rightarrow x-2 = 0 \text{ (or) } x-1 = 0$$

$$\Rightarrow x = 2 \text{ (or) } 1$$

The roots of the given equation are 1 (or) 2

13) The sum of the reciprocals of Rehman's ages, (in years) 3 years ago and 5 years from now is $\frac{1}{3}$. Find his present age.

Sol: Let the present age of Rehman = x years

3 years ago of Rehman = $x - 3$ years

After 5 years, the age of Rehman = $x + 5$ years

Given that the sum of the reciprocals of Rehman's ages, 3 years ago and 5 years from now is $\frac{1}{3}$.

$$\text{i.e. } \frac{1}{x-3} + \frac{1}{x+5} = \frac{1}{3}$$

Multiplying with $3(x-3)(x+5)$, we get

$$\Rightarrow 3(x+5) + 3(x-3) = (x-3)(x+5)$$

$$\Rightarrow 3x + 15 + 3x - 9 = x^2 + 5x - 3x - 15$$

$$\Rightarrow 6x + 6 = x^2 + 2x - 15$$

$$\Rightarrow x^2 + 2x - 15 - 6x - 6 = 0$$

$$\Rightarrow x^2 - 4x - 21 = 0$$

$$\Rightarrow x^2 - 7x + 3x - 21 = 0$$

$$\Rightarrow x(x-7) + 3(x-7) = 0$$

$$\Rightarrow (x-7)(x+3) = 0$$

$$\Rightarrow (x-7) = 0 \text{ (or) } (x+3) = 0$$

$$\Rightarrow x = 7 \text{ (or) } x = -3$$

But age is not negative.

\therefore Present age of Rehman = 7 years.

- 14) In a class test, the sum of Moulika's marks in mathematics and English is 30. If she got 22 marks more in mathematics and 3 marks less in English, the product of her marks would have been 210. Find her marks in the two subjects?**

Sol: Sum of Moulika's marks in Mathematics and English is 30.

Let the marks in Maths = x

Then the marks in English = $30 - x$

If she got 2 marks more in Maths, and 3 marks less in English, the product of marks = 210.

$$\text{i.e. } (x+2)(30-x-3) = 210$$

$$\Rightarrow (x + 2)(27 - x) = 210$$

$$\Rightarrow 27x - x^2 + 54 - 2x - 210 = 0$$

$$\Rightarrow -x^2 + 25x - 156 = 0$$

$$\Rightarrow x^2 - 25x + 156 = 0$$

$$\Rightarrow x^2 - 13x - 12x + 156 = 0 \quad (\because 1 \times 156 = 156 \rightarrow -13 \times -12)$$

$$\Rightarrow x(x - 13) - 12(x - 13) = 0$$

$$\Rightarrow (x - 13)(x - 12) = 0$$

$$\Rightarrow (x - 13) = 0 \text{ (or) } (x - 12) = 0$$

$$\Rightarrow x = 13 \text{ (or) } x = 12$$

If marks in Maths $x = 13$, then marks in English $= 30 - x = 30 - 13 = 17$

If marks in Maths $x = 12$, then marks in English $= 30 - 12 = 18$

15) The diagonal of a rectangular field is 60 meters more than the shorter side. If the longer side is 30 meters more than the shorter side, find the sides of the field?

Sol: Let the length of the shorter side (breadth) = x meters.

Then the length of longer side = $x + 30$ meters (Given)

The length of diagonal = $x + 60$ (Given)

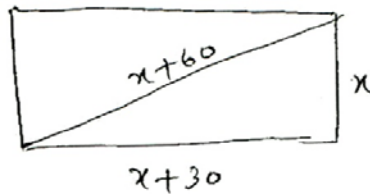

By pythagorus theorem

$$(x+60)^2 = (x+30)^2 + x^2$$

$$\Rightarrow x^2 + 120x + 3600 = x^2 + 60x + 900 + x^2$$

$$\Rightarrow x^2 + 60x + 900 - 120x - 3600 = 0$$

$$\Rightarrow x^2 - 60x - 2700 = 0$$

$$\Rightarrow x^2 - 90x + 30x - 2700 = 0 \quad (\because 1 \times -270 = -270)$$

$$\Rightarrow x(x - 90) + 30(x - 90) = 0$$

$$\Rightarrow (x - 90)(x + 30) = 0$$

$$\Rightarrow x = 90 \text{ (or) } x = -30$$

Length of the shorter side (x) never be negative.

Length of the shorter side = 90m

Length of longer side = $90 + 30 = 120\text{m}$

Length of diagonal = $90 + 60 = 150\text{ m}$

16) The difference of squares of two numbers is 180. The square of the smaller number is 8 times the larger number. Find the two numbers?

Sol: Let the larger number = x

Square of the larger number = x^2

Square of the smaller number = 8 times the larger number (Given)

$$= 8x$$

Given that difference of squares of two numbers is 180

$$\text{i.e. } x^2 - 8x = 180$$

$$\Rightarrow x^2 - 8x - 180 = 0$$

$$\Rightarrow x^2 - 18x + 10x - 180 = 0$$

$$\Rightarrow x(x - 18) + 10(x - 18) = 0$$

$$\Rightarrow (x - 18)(x + 10) = 0$$

$$\Rightarrow (x - 18) = 0 \text{ (or) } (x + 10) = 0$$

$$\Rightarrow x = 18 \text{ (or) } -10$$

\therefore The larger number $x = 18$ ($x \neq -10$)

The square of smaller number = $8 \times x = 8 \times 18 = 144$

The smaller number = $\sqrt{144} = \pm 12$

The two numbers are 18 and 12 (or) 18 and -12

17) A train travels 360 km at a uniform speed. If the speed had been 5km/h more, it would have taken 1 hour less for the same journey. Find the speed of the train?

Sol: The distance travelled by a train = 360 km

Let the speed of the train = x km/h

If the speed of the train increased 5 km/h, then the speed of the train = (x + 5) km/h

The time taken by the train, to cover 360 km distance with the speed x km/h is $\frac{360}{x}$.

The time taken by the train, to cover 360 km distance with the speed x + 5 km/h is $\frac{360}{x+5}$.

Difference between the two timings = 1 hour

$$\text{i.e. } \frac{360}{x} - \frac{360}{x+5} = 1$$

Multiplying with x (x + 5), we get

$$\Rightarrow 360(x + 5) - 360x = x(x + 5)$$

$$\Rightarrow 360x + 1800 - 360x = x^2 + 5x$$

$$\Rightarrow x^2 + 5x - 1800 = 0$$

$$\Rightarrow x^2 + 45x - 40x - 1800 = 0$$

$$\Rightarrow x(x + 45) - 40(x + 45) = 0$$

$$\Rightarrow (x + 45)(x - 40) = 0$$

$$\Rightarrow (x - 40) = 0 \text{ (or) } (x + 45) = 0$$

$$\Rightarrow x = 40 \text{ (or) } x = -45$$

\therefore Speed of the train x = 40 km/h (x = -45 net negative)

- 18) Two water taps together can fill a tank in $9\frac{3}{8}$ hours. The tap of larger diameter takes 10 hours less than the smaller one to fill the tank separately. Find the time in which each tap can separately fill the tank.

Sol: Total time takes by two water taps together can fill a tank

$$= 9\frac{3}{8} = \frac{75}{8} \text{ Hours}$$

The part of the tank filled by the two taps together in 1 hour is

$$= \frac{1}{\frac{75}{8}} = \frac{8}{75}$$

Time taken by the smaller diameter tap to fill the tank = x hours.

The tap of larger diameter takes 10 hours less than the smaller one to fill the tank.

i.e The time taken by the larger diameter tap to fill the tank = x – 10 hours

Part of the tank filled by the smaller diameter tap in 1 hour = $\frac{1}{x}$

Part of the tank filled by the larger diameter tap in 1 hour = $\frac{1}{x-10}$.

$$\text{But } \frac{1}{x} + \frac{1}{x-10} = \frac{8}{75} \text{ (From the problem)}$$

Multiplying with $75x(x-10)$ on both sides

$$\Rightarrow 75(x-10) + 75x = 8(x)(x-10)$$

$$\Rightarrow 75x - 750 + 75x = 8x^2 - 80x$$

$$\Rightarrow 8x^2 - 80x - 150x + 750 = 0$$

$$\Rightarrow 8x^2 - 230x + 750 = 0$$

$$\Rightarrow 8x^2 - 200x - 30x + 750 = 0$$

$$\Rightarrow 8x(x-25) - 30(x-25) = 0$$

$$\Rightarrow (x-25)(8x-30) = 0$$

$$\Rightarrow (8x - 30) = 0 \text{ (or) } (x - 25) = 0$$

$$\Rightarrow x = 30/8 = 15/4 \text{ (or) } x = 25$$

$$x \neq \frac{15}{4} \text{ (The big tap takes 10 hours less than the small tap)}$$

$$\therefore x = 25 \text{ hours}$$

Time taken by the smaller diameter tap to fill the tank separately = 25 hours

Time taken by the larger diameter tap to fill the tank separately

$$= x - 10$$

$$= 25 - 10$$

$$= 15 \text{ hours.}$$

- 19) An express train takes 1 hour less than a passenger train to travel 132 km between Mysore and Bangalore (Without taking into consideration the time they stop at intermediate stations). If the Average Speed of the express train is 11 km/h more than that of the passenger train, find the average speed of the two trains.**

Sol: Let the speed of passenger train = x km/h.

Then the speed of express train = $x + 11$ km/h

The distance travelled by two trains = 132 km.

Difference time between the two trains = 1 hour

$$\text{i.e. } \frac{132}{x} - \frac{132}{x+11} = 1$$

Multiplying with $x(x + 11)$ on both sides we get,

$$\Rightarrow 132(x + 11) - 132x = x(x + 11)$$

$$\Rightarrow 132x + 1452 - 132x = x^2 + 11x$$

$$\Rightarrow x^2 + 11x - 1452 = 0$$

$$\Rightarrow x^2 + 44x - 33x - 1452 = 0$$

$$\Rightarrow x(x + 44) - 33(x + 44) = 0$$

$$\Rightarrow (x + 44)(x - 33) = 0$$

$$\Rightarrow (x + 44) = 0 \text{ (or) } (x - 33) = 0$$

$$\Rightarrow x = -44 \text{ (or) } x = 33$$

Speed of the passenger train = 33 km/h ($x \neq -44$ not negative)

Speed of the express train = $x + 11 = 33 + 11 = 44$ km/h

20) Sum of the areas of two squares is 468m^2 . If the difference of their perimeters is 24m, find the sides of the two squares.

Sol: Let the side of the big square = x m.

Then the perimeter of the big square = $4x$ m.

Difference of the two squares perimeters = 24m.

The perimeter of the small square = $4x - 24$

$$\text{Side of the small square} = \frac{4x - 24}{4} = x - 6$$

Area of the big square = x^2

Area of the small square = $(x - 6)^2$

Given that sum of the areas of two squares is 468m^2

$$\Rightarrow x^2 + (x - 6)^2 = 468$$

$$\Rightarrow x^2 + x^2 - 12x + 36 = 468$$

$$\Rightarrow 2x^2 - 12x + 36 - 468 = 0$$

$$\Rightarrow 2x^2 - 12x - 432 = 0$$

$$\Rightarrow x^2 - 6x - 216 = 0$$

$$\Rightarrow x^2 - 18x + 12x - 216 = 0$$

$$\Rightarrow x(x - 18) + 12(x - 18) = 0$$

$$\Rightarrow (x - 18)(x + 12) = 0$$

$$\Rightarrow (x - 18) = 0 \text{ (or) } (x + 12) = 0$$

$$\Rightarrow X = 18 \text{ (or) } x = -12$$

Side of the big square $x = 18$ m ($x \neq -12$ Not Negative)

Side of the small square $= x - 6 = 18 - 6 = 12$ m.

- 21) A ball is thrown vertically upward from the top of the building 96 feet tall with an initial velocity 80 m/second. The distance 's' of the ball from the ground after 't' seconds is $s = 96 + 80t - 16t^2$. After how many seconds does the ball strike the ground?**

Sol: Let the ball strike the ground at 't' sec.

Distance between the ball and the ground after 't' secs is '0'.

Given that the distance 's' of the ball from the ground after 't' seconds is

$$s = 96 + 80t - 16t^2$$

$$\text{i.e } \Rightarrow 96 + 80t - 16t^2 = 0$$

$$\Rightarrow -16(t^2 - 5t - 6) = 0$$

$$\Rightarrow (t^2 - 5t - 6) = 0$$

$$\Rightarrow t^2 - 6t + t - 6 = 0$$

$$\Rightarrow t(t - 6) + 1(t - 6) = 0$$

$$\Rightarrow (t + 1) = 0 \text{ (or) } (t - 6) = 0$$

$$\Rightarrow t = -1 \text{ (or) } t = 6$$

Time, 't' never be negative, i.e $t \neq -1$

$$\therefore t = 6$$

After 6 seconds the ball strike the ground.

- 22) If a polygon of 'n' sides has $\frac{1}{2}n(n-3)$ diagonal. How many sides will a polygon having 65 diagonals? Is there a problem with a 50 diagonals?**

Sol: Given that No. of diagonals of a polygon of 'n' sides $\frac{1}{2}n(n-3)$

Number of diagonals of a given polygon = 65

$$\frac{1}{2}n(n-3) = 65$$

$$\Rightarrow n(n-3) = 65 \times 2 = 130$$

$$\Rightarrow n^2 - 3n - 130 = 0$$

$$\Rightarrow n^2 - 13n + 10n - 130 = 0$$

$$\Rightarrow n(n-13) + 10(n-13) = 0$$

$$\Rightarrow (n-13)(n+10) = 0$$

$$\Rightarrow (n-13) = 0 \text{ (or) } (n+10) = 0$$

$$\Rightarrow n = 13 \text{ (or) } n = -10$$

No. of sides are not negative

\therefore Number of sides of a given polygon = 13

To check there is a polygon with 50 diagonals

$$\text{i.e. } \frac{1}{2}n(n-3) = 50$$

$$\Rightarrow n(n-3) = 100$$

$$\Rightarrow n^2 - 3n - 100 = 0$$

Compare with $ax^2 + bx + c = 0$, $a = 1$, $b = -3$, $c = -100$

$$b^2 - 4ac = (-3)^2 - 4(1)(-100) = 9 + 400 = 409$$

$$n = \frac{-b \pm \sqrt{b^2 - 4ac}}{2a}$$

$$n = \frac{-(-3) \pm \sqrt{409}}{2(1)}$$

$$n = \frac{3 \pm \sqrt{409}}{2}$$

Since n is not a natural number (countable number)

\therefore We can't find the sides of the polygon.

∴ There can't be a polygon with 50 diagonals.

23) Find the discriminant of the following quadratic equations and hence find the nature of its roots. Find them, if they are real?

i. $3x^2 - 2x + 1/3 = 0$

ii. $2x^2 - 3x + 5 = 0$

Sol:

i. Given quadratic equation $3x^2 - 2x + 1/3 = 0$.

Compare with $ax^2 + bx + c = 0$, $a = 3$, $b = -2$, $c = 1/3$

Discriminant = $b^2 - 4ac = (-2)^2 - 4(3)(1/3) = 4 - 4 = 0$

The roots are

$$n = \frac{-b \pm \sqrt{b^2 - 4ac}}{2a}$$

$$n = \frac{-(-2) \pm \sqrt{0}}{2(3)}$$

$$n = \frac{2}{6} = \frac{1}{3}$$

The two equal roots are $\frac{1}{3}, \frac{1}{3}$

ii. Given quadratic equation $2x^2 - 3x + 5 = 0$.

Compare with $ax^2 + bx + c = 0$, $a = 2$, $b = -3$, $c = 5$

∴ Discriminant = $b^2 - 4ac = (-3)^2 - 4(2)(5) = 9 - 40 = -31 < 0$

So, the given equation has no real roots.

24) It is possible to design a rectangular mango grove whose length is twice its breadth, and the area is 800 m²? If so, find its length and breadth?

Sol: Let the breadth of the rectangular mango grove = x m.

∴ Given that length is twice its breadth.

$$\text{Length} = 2x \text{ m.}$$

$$\text{Area} = l \times b = 2x \times x = 800$$

$$\Rightarrow 2x^2 = 800$$

$$\Rightarrow x^2 = \frac{800}{2} = 400$$

$$\Rightarrow x^2 - 400 = 0 \text{ -----(1)}$$

$$\text{Compare with } ax^2 + bx + c = 0, a = 1, b = 0, c = -400$$

$$\therefore \text{Discriminant} = b^2 - 4ac = (0)^2 - 4(1)(-400) = 1600 > 0$$

(Discriminant > 0)

i.e. ∴ It is possible to find breadth (x), and length (2x).

∴ It is possible to design a rectangular mango grove.

From equation (1)

$$x = \frac{-b \pm \sqrt{b^2 - 4ac}}{2a}$$

$$x = \frac{0 \pm \sqrt{1600}}{2(1)}$$

$$\Rightarrow x = \frac{40}{2} = 20$$

∴ Breadth (x) = 20m, Length (2x) = 2 × 20 = 40 m.

25) The sum of the ages of two friends is 25 years. Four years ago, the product of their ages in years was 48. Is the situation possible? If so, determine their present ages?

Sol: Let the ages of two friends be x , $20 - x$

(Given that sum of the ages of two friends is 20 years)

4 years ago their ages are $x - 4$; $20 - x - 4$

Given that $(x - 4)(20 - x - 4) = 48$

$$\Rightarrow (x - 4)(16 - x) = 48$$

$$\Rightarrow 16x - x^2 - 64 + 4x = 48$$

$$\Rightarrow -x^2 + 20x - 64 - 48 = 0$$

$$\Rightarrow x^2 - 20x + 112 = 0 \text{ -----(1)}$$

Compare with $ax^2 + bx + c = 0$, $a = 1$, $b = -20$, $c = 112$

$$\therefore \text{Discriminant} = b^2 - 4ac = (-20)^2 - 4(1)(112) = 400 - 448 = -48 < 0$$

(Discriminant < 0)

It is not possible to find real root for equation (1)

\therefore The situation is not possible.

26) It is possible to design a rectangular park of perimeter 80 m. and area 400m^2 ? If so, find its length and breadth?

Sol: Let the length and breadth be l and b .

Given that perimeter 80m, and area 400m^2 .

$$\text{i.e. } 2(l + b) = 80$$

$$\Rightarrow l + b = 40 \text{ ---- (1)}$$

$$\Rightarrow lb = 400 \text{ ----- (2)}$$

Let the breadth of the rectangle be $(b) = x$ m.

Then from equation (1) we get $l + x = 40 \Rightarrow l = 40 - x$

From equation (2) $lb = 400$

$$\Rightarrow (40 - x)(x) = 400$$

$$\Rightarrow 40x - x^2 = 400$$

$$\Rightarrow 40x - x^2 - 400 = 0$$

$$\Rightarrow x^2 - 40x + 400 = 0 \text{ -----(3)}$$

Compare with $ax^2 + bx + c = 0$, $a = 1$, $b = -40$, $c = 400$

$$\therefore \text{Discriminant} = b^2 - 4ac = (-40)^2 - 4(1)(400) = 1600 - 1600 = 0$$

Since discriminant = 0, we can find real roots of equation (3)

i.e. \therefore It is possible to design a rectangular park.

From equation (3)

$$x = \frac{-b \pm \sqrt{b^2 - 4ac}}{2a}$$

$$x = \frac{-(-40) \pm \sqrt{0}}{2(1)}$$

$$\Rightarrow x = \frac{40}{2} = 20$$

$$\therefore \text{Breadth (x)} = 20\text{m}$$

$$\text{Length} = 40 - x = 40 - 20 = 20 \text{ m.}$$

27) Solve the following quadratic equations by factorization method.

i. $4x^2 - 2(a^2 + b^2)x + a^2 b^2 = 0$

ii. $9x^2 - 9(a + b)x + (2a^2 + 5ab + 2b^2) = 0$

Sol:

i. Given quadratic equation $4x^2 - 2(a^2 + b^2)x + a^2 b^2 = 0$

$$(4 \times a^2 b^2 = 4a^2 b^2)(4a^2 b^2 = -2a^2 \times -2b^2)$$

$$\therefore 4x^2 - 2(a^2 + b^2)x + a^2 b^2 = 0$$

$$\Rightarrow 4x^2 - 2a^2x - 2b^2x + a^2b^2 = 0$$

$$\Rightarrow 2x(2x - a^2) - b^2(2x - a^2) = 0$$

$$\Rightarrow (2x - a^2)(2x - b^2) = 0$$

$$\Rightarrow (2x - a^2) = 0 \text{ (or) } (2x - b^2) = 0$$

$$\Rightarrow x = \frac{a^2}{2} \text{ or } \frac{b^2}{2}$$

ii. Given quadratic equation $9x^2 - 9(a + b)x + (2a^2 + 5ab + 2b^2) = 0$

Co-efficient of $x^2 \times$ constant term

$$= 9 \times (2a^2 + 5ab + 2b^2)$$

$$= 9 \times (2a^2 + 4ab + ab + 2b^2)$$

$$= 9(2a(a + 2b) + b(a + 2b))$$

$$= 9(a + 2b)(2a + b)$$

$$-3((a + 2b), (2a + b))$$

$$\therefore 9x^2 - 9(a + b)x + (2a^2 + 5ab + 2b^2) = 0$$

$$\Rightarrow 9x^2 - 3(a + 2b + 2a + b)x + (2a^2 + 5ab + 2b^2) = 0$$

$$\Rightarrow 9x^2 - 3(a + 2b)x - 3(2a + b)x + (a + 2b)(2a + b) = 0$$

$$\Rightarrow 3x[3x - (a + 2b)] - 3(2a + b)[3x - (a + 2b)] = 0$$

$$\Rightarrow [3x - (a + 2b)][3x - (2a + b)] = 0$$

$$\Rightarrow x = \frac{a + 2b}{3} \text{ (or) } \frac{(2a + b)}{3}$$

Model Problem

Solve the following quadratic equations by factorization method.

$$(i) x^2 + \left(\frac{a}{a+b} + \frac{a+b}{a} \right) x + 1 = 0$$

$$(ii) \frac{1}{a+b+x} = \frac{1}{a} + \frac{1}{b} + \frac{1}{x}$$

$$(iii) \frac{x-1}{x-2} + \frac{x-3}{x-4} = 3\frac{1}{3} (x \neq 2, 4)$$

$$(iv) x^2 - 2(a^2 + b^2)x + (a^2 - b^2)^2 = 0$$

Sol: (i) $x = -\frac{a}{a+b}$ (or) $-\frac{(a+b)}{a}$

(ii) $x = -a$ (or) $x = -b$

(iii) $x = 5$ (or) $\frac{5}{2}$

(iv) $x = (a^2 + b^2) \pm 2ab$

28) Solve the following equations by the method of completing the square?

(i) $4x^2 + 4bx - (a^2 - b^2) = 0$

(ii) $a^2x^2 - 3abx + 2b^2 = 0$

Sol:

(i) Given quadratic equation $4x^2 + 4bx - (a^2 - b^2) = 0$

Dividing on both sides by 4, we get

$$\Rightarrow x^2 + bx - \left(\frac{a^2 - b^2}{4} \right) = 0$$

$$\Rightarrow x^2 + bx = \left(\frac{a^2 - b^2}{4} \right)$$

$$\Rightarrow x^2 + 2(x)\left(\frac{b}{2}\right) = \left(\frac{a^2 - b^2}{4}\right)$$

Adding $\left(\frac{b}{2}\right)^2$ on both sides, we get

$$\Rightarrow x^2 + 2(x)\left(\frac{b}{2}\right) + \left(\frac{b}{2}\right)^2 = \left(\frac{a^2 - b^2}{4}\right) + \left(\frac{b}{2}\right)^2$$

$$\Rightarrow \left(x + \frac{b}{2}\right)^2 = \frac{a^2 - b^2 + b^2}{4} = \frac{a^2}{4} = \left(\frac{a}{2}\right)^2$$

$$\Rightarrow x + \frac{b}{2} = \sqrt{\left(\frac{a}{2}\right)^2}$$

$$\Rightarrow x + \frac{b}{2} = \pm \frac{a}{2}$$

$$\Rightarrow x = -\frac{b}{2} \pm \frac{a}{2}$$

$$\Rightarrow x = -\frac{b}{2} + \frac{a}{2} \text{ (or) } x = -\frac{b}{2} - \frac{a}{2}$$

$$\Rightarrow x = \frac{a-b}{2} \text{ (or) } x = -\frac{(a+b)}{2}$$

(ii) Given quadratic equation $a^2x^2 - 3abx + 2b^2 = 0$

Dividing both sides by a^2 , we get

$$\Rightarrow x^2 - \frac{3ab}{a^2}x + 2\frac{b^2}{a^2} = 0$$

$$\Rightarrow x^2 - 3\left(\frac{b}{a}\right)x + 2\frac{b^2}{a^2} = 0$$

$$\Rightarrow x^2 - 3\left(\frac{b}{a}\right)x = -2\frac{b^2}{a^2}$$

$$\Rightarrow x^2 - 2x\left(\frac{3b}{2a}\right) = -2\frac{b^2}{a^2} \dots$$

Adding $\left(\frac{3b}{2a}\right)^2$ on both sides

$$\Rightarrow x^2 - 2x\left(\frac{3b}{2a}\right) + \left(\frac{3b}{2a}\right)^2 = -2\frac{b^2}{a^2} + \left(\frac{3b}{2a}\right)^2$$

$$\Rightarrow \left(x - \frac{3b}{2a}\right)^2 = -2\frac{b^2}{a^2} + \frac{9b^2}{4a^2} = \frac{-8b^2 + 9b^2}{4a^2} = \frac{b^2}{4a^2} = \left(\frac{b}{2a}\right)^2$$

$$\Rightarrow x - \frac{3b}{2a} = \sqrt{\left(\frac{b}{2a}\right)^2} = \pm \frac{b}{2a}$$

$$\Rightarrow x = \pm \frac{b}{2a} + \frac{3b}{2a}$$

$$\Rightarrow x = \frac{\pm b + 3b}{2a}$$

$$\Rightarrow x = \frac{-b + 3b}{2a} \text{ (or) } x = \frac{+b + 3b}{2a}$$

$$\Rightarrow x = \frac{2b}{2a} \text{ (or) } x = \frac{4b}{2a}$$

$$\Rightarrow x = \frac{b}{a} \text{ (or) } x = \frac{2b}{a}$$

Model Problem:

Solve the following quadratic equations by the method of completing the square.

(i) $ax^2 + bx + c = 0$

(ii) $x^2 - 4ax + 4a^2 - b^2 = 0$

(iii) $x^2 - (\sqrt{3} + 1)x + \sqrt{3} = 0$

(iv) $\sqrt{2}x^2 - 3x - 2\sqrt{2} = 0$

Answers:

(i) $x = \frac{-b \pm \sqrt{b^2 - 4ac}}{2a}$

(ii) $x = 2a - b$ (or) $2a + b$

(iii) $x = \sqrt{3}, 1$

$$(iv) \quad -\frac{1}{\sqrt{2}}, 2\sqrt{2}$$

29) Solve the following problems, using quadratic formula.

$$(i) \quad 12abx^2 - (9a^2 - 8b^2)x - 6ab = 0$$

$$(ii) \quad a^2 b^2 x^2 - (4b^4 - 3a^4)x - 12a^2 b^2 = 0$$

Sol:

$$(i) \quad \text{Given quadratic equation} \quad 12abx^2 - (9a^2 - 8b^2)x - 6ab = 0$$

Compare with $Ax^2 + Bx + C = 0$, we get

$$A = 12ab ; B = -(9a^2 - 8b^2) ; C = -6ab$$

Using the quadratic formula, we get

$$x = \frac{-b \pm \sqrt{b^2 - 4ac}}{2a}$$

$$x = \frac{-[-(9a^2 - 8b^2)] \pm \sqrt{[-(9a^2 - 8b^2)]^2 - 4(12ab)(-6ab)}}{2(12ab)}$$

$$x = \frac{9a^2 - 8b^2 \pm \sqrt{81a^4 + 64b^4 - 144a^2b^2 + 288a^2b^2}}{24ab}$$

$$x = \frac{9a^2 - 8b^2 \pm \sqrt{81a^4 + 64b^4 + 144a^2b^2}}{24ab}$$

$$x = \frac{9a^2 - 8b^2 \pm \sqrt{(9a^2 + 8b^2)^2}}{24ab}$$

$$x = \frac{9a^2 - 8b^2 \pm 9a^2 + 8b^2}{24ab}$$

$$x = \frac{9a^2 - 8b^2 + 9a^2 + 8b^2}{24ab} \quad (or) \quad x = \frac{9a^2 - 8b^2 - 9a^2 - 8b^2}{24ab}$$

$$x = \frac{18a^2}{24ab} \quad (or) \quad x = \frac{-16b^2}{24ab}$$

$$x = \frac{3a}{4b} \quad (or) \quad x = \frac{-2b}{3a}$$

(ii) Given quadratic equation $a^2 b^2 x^2 - (4b^4 - 3a^4) x - 12a^2 b^2 = 0$

Compare with $Ax^2 + Bx + C = 0$, we get

$A = a^2 b^2$; $B = -(4b^4 - 3a^4)$; $C = -12$

Using the quadratic formula, we get

$$x = \frac{-b \pm \sqrt{b^2 - 4ac}}{2a}$$

$$x = \frac{-[-(4b^4 - 3a^4)] \pm \sqrt{(-(4b^4 - 3a^4))^2 - 4(a^2 b^2)(-12a^2 b^2)}}{2a^2 b^2}$$

$$x = \frac{4b^4 - 3a^4 \pm \sqrt{16b^8 + 9a^8 - 24b^4 a^4 + 48a^4 b^4}}{2a^2 b^2}$$

$$x = \frac{4b^4 - 3a^4 \pm \sqrt{16b^8 + 9a^8 + 24b^4 a^4}}{2a^2 b^2}$$

$$x = \frac{4b^4 - 3a^4 \pm \sqrt{(4b^4 + 3a^4)^2}}{2a^2 b^2}$$

$$x = \frac{4b^4 - 3a^4 \pm 4b^4 + 3a^4}{2a^2 b^2}$$

$$x = \frac{4b^4 - 3a^4 + 4b^4 + 3a^4}{2a^2 b^2} \text{ (or) } x = \frac{4b^4 - 3a^4 - 4b^4 - 3a^4}{2a^2 b^2}$$

$$x = \frac{8b^4}{2a^2 b^2} \text{ (or) } x = \frac{-6a^4}{2a^2 b^2}$$

$$x = \frac{4b^2}{a^2} \text{ (or) } x = \frac{-3a^2}{2b^2}$$

Model Problem:

Solve the following problem, using quadratic formula.

(i) $(a + b)^2 x^2 + 8(a^2 - b^2) + 16(a - b)^2 = 0$, $a + b \neq 0$, $a \neq b$

(ii) $3x^2 a^2 + 8abx + 4b^2 = 0$, $a \neq 0$

Answers:

$$(i) \quad -4\left(\frac{a-b}{a+b}\right), -4\left(\frac{a-b}{a+b}\right)$$

$$(ii) \quad -\frac{2b}{a}, -\frac{2b}{3a}$$

30) Find the values of k for which the following equation has equal roots.

$$(k - 12)x^2 + 2(k - 12)x + 2 = 0$$

Sol: Given quadratic equation $(k - 12)x^2 + 2(k - 12)x + 2 = 0$ ----(1)

Compare with $ax^2 + bx + c = 0$, we get

$$a = k - 12 ; b = 2(k - 12); c = 2$$

Given that the roots of equation (1) are equal

i.e. discriminant $D = 0$

$$\Rightarrow b^2 - 4ac = 0$$

$$\Rightarrow (2(k - 12))^2 - 4(k - 12)(2) = 0$$

$$\Rightarrow 4(k - 12)^2 - 8(k - 12) = 0$$

$$\Rightarrow 4[(k - 12)^2 - 2(k - 12)] = 0$$

$$\Rightarrow (k - 12)^2 - 2(k - 12) = 0$$

$$\Rightarrow (k - 12)[(k - 12) - 2] = 0$$

$$\Rightarrow (k - 14)(k - 12) = 0$$

$$\Rightarrow (k - 14) = 0 \text{ (or) } (k - 12) = 0$$

$$\Rightarrow k = 14 \text{ (or) } k = 12$$

31) Prove that the equation $x^2 (a^2 + b^2) + 2x (ac + bd) + (c^2 + d^2) = 0$ has no real roots, if $ad \neq bc$.

Sol: Given quadratic equation

$$x^2 (a^2 + b^2) + 2x (ac + bd) + (c^2 + d^2) = 0$$

Compare with $ax^2 + bx + c = 0$, we get

$$a = a^2 + b^2; \quad b = 2(ac + bd); \quad c = c^2 + d^2$$

$$\text{Discriminant (d)} = b^2 - 4ac$$

$$= [2(ac + bd)]^2 - 4(a^2 + b^2)(c^2 + d^2)$$

$$= 4(a^2 c^2 + a^2 d^2 + 2abcd) - 4(a^2 c^2 + a^2 d^2 + b^2 c^2 + b^2 d^2)$$

$$= 4[a^2 c^2 + a^2 d^2 + 2abcd - a^2 c^2 - a^2 d^2 - b^2 c^2 - b^2 d^2]$$

$$= 4[-a^2 d^2 - b^2 c^2 + 2abcd]$$

$$= -4[a^2 d^2 + b^2 c^2 - 2abcd]$$

$$= -4[(ad - bc)^2]$$

Given that $ad \neq bc$

$$\Rightarrow ad - bc \neq 0$$

$$\Rightarrow (ad - bc)^2 > 0$$

$$D = -4(ad - bc)^2 < 0$$

$$(\because (ad - bc)^2 < 0 \quad -(ad - bc)^2 > 0)$$

Since $D < 0$, the given equation has no real roots.

32) If the roots of the equation $x^2 + 2cx + ab = 0$ are real unequal, prove that the equation $x^2 - 2(a + b)x + a^2 + b^2 + 2c^2 = 0$ has no real roots.

Sol: Given quadratic equations,

$$x^2 + 2cx + ab = 0 \text{ ---- (i)}$$

$$x^2 - 2(a + b)x + a^2 + b^2 + 2c^2 = 0 \text{ ----(ii)}$$

Since the roots of equation (i) are real and unequal.

$$\therefore \text{Discriminant } d = b^2 - 4ac > 0$$

$$\Rightarrow (2c)^2 - 4(1)(ab) > 0$$

$$\Rightarrow 4(c^2 - ab) > 0$$

$$\Rightarrow c^2 - ab > 0 (\because 4 > 0)$$

From the equation (2)

$$\text{Discriminant } d = b^2 - 4ac$$

$$\Rightarrow (-2(a+b))^2 - 4(a)(a^2 + b^2 + 2c^2)$$

$$\Rightarrow 4[a^2 + b^2 + 2ab - a^2 - b^2 - 2c^2]$$

$$\Rightarrow 4[2ab - 2c^2]$$

$$\Rightarrow 8(ab - c^2)$$

$$\Rightarrow -8(c^2 - ab) < 0 (\because c^2 - ab > 0)$$

Since $d < 0$, roots of equation (2) are not real.

SHORT ANSWER QUESTIONS

1) Check whether the following are quadratic equations?

(i) $x^3 - 4x^2 - x + 1 = (x - 2)^3$

(ii) $(x - 2)(x + 1) = (x - 1)(x + 3)$

Sol:

(i) Given $x^3 - 4x^2 - x + 1 = (x - 2)^3$

$$\Rightarrow x^3 - 4x^2 - x + 1 = x^3 - 8 + 3x(2)^2 - 3x^2(2)$$

$$((a - b)^3 = a^3 - b^3 - 3a^2b + 3ab^2)$$

$$\Rightarrow x^3 - 4x^2 - x + 1 = x^3 - 8 + 12x - 6x^2$$

$$\Rightarrow 6x^2 - 4x^2 - x - 12x + 1 + 8 = 0$$

$$\Rightarrow 2x^2 - 13x + 9 = 0$$

It is in the form of $ax^2 + bx + c = 0$, $a \neq 0$.

Hence the given equation is a quadratic equation.

(ii) Given $(x - 2)(x + 1) = (x - 1)(x + 3)$

$$\Rightarrow x^2 + x - 2x - 2 = x^2 + 3x - x - 3$$

$$\Rightarrow -x - 2 - 2x + 3 = 0$$

$$\Rightarrow -3x + 1 = 0$$

$$\Rightarrow 3x - 1 = 0$$

It is not in the form of $ax^2 + bx + c = 0$, $a \neq 0$.

Hence the given equation is not a quadratic equation.

2) Report the following situation in the form of quadratic equation?

(i) **Rohan's mother is 26 years older than him. The product of their ages after 3 years will be 360 years, we need to find Rohan's Present age.**

(ii) **A train travels a distance of 480km at a uniform speed. If the speed had been 8km/h less, then it would have taken 3 hours more to cover the same distance. We need to find the speed of train?**

Sol:

- (i) Let Rohan's present age = x years.

Then, the present age of his mother = $(x + 26)$ years (Given)

3 years from now (After 3 years)

Age of Rohan = $(x + 3)$ years

Age of his mother = $x + 26 + 3 = x + 29$

Given that product of their ages will be 360

$$\text{i.e. } (x + 3)(x + 29) = 360$$

$$\Rightarrow x^2 + 29x + 3x + 87 = 360$$

$$\Rightarrow x^2 + 32x - 87 = 0$$

\therefore Rohan's present age satisfies the quadratic equation

$$x^2 + 32x - 87 = 0$$

- (ii) Let the uniform speed of the train = x km/hour

The distance travelled by the train = 480 km.

$$\text{Time taken by the train} = \frac{\text{distance}}{\text{speed}} = \frac{480}{x}$$

If the speed had been 8 km/h less, then the speed of the train = $(x - 8)$ km/h

$$\text{Time taken by the train when the speed increase} = \frac{480}{x-8}$$

Difference between the two timings $s = 3$ hours

$$\text{i.e. } \frac{480}{x-8} - \frac{480}{x} = 3$$

Uniform speed of train satisfies the quadratic equation.

$$\frac{480}{x-8} - \frac{480}{x} = 3$$

3) Find two numbers whose sum is 27 and product is 182.

Sol: Let the numbers are $x, (27 - x)$

(\therefore Given sum is 27)

Given that product of that two numbers = 182

$$\Rightarrow x(27 - x) = 182$$

$$\Rightarrow 27x - x^2 = 182$$

$$\Rightarrow 27x - x^2 - 182 = 0$$

$$\Rightarrow x^2 - 27x + 182 = 0$$

$$\Rightarrow x^2 - 13x - 14x + 182 = 0$$

$$\Rightarrow x(x - 13) - 14(x - 13) = 0$$

$$\Rightarrow (x - 13)(x - 14) = 0$$

$$\Rightarrow (x - 13) = 0 \text{ (or) } (x - 14) = 0$$

$$\Rightarrow x = 13 \text{ (or) } x = 14$$

$$27 - x = 27 - 13 \text{ (or) } 27 - 14 = 14 \text{ (or) } 13$$

So the required two numbers are 13, 14.

4) Solve the quadratic equation $\frac{2}{5}x^2 - x - \frac{3}{5} = 0$ by factorization method?

Sol:

Given quadratic equation $\frac{2}{5}x^2 - x - \frac{3}{5} = 0$

$$\Rightarrow \frac{2x^2 - 5x - 3}{5} = 0$$

$$\Rightarrow 2x^2 - 5x - 3 = 0$$

$$\Rightarrow 2x^2 - 6x + x - 3 = 0$$

$$\Rightarrow 2x(x - 3) + 1(x - 3) = 0$$

$$\Rightarrow (x - 3)(2x + 1) = 0$$

$$\Rightarrow (x - 3) = 0 \text{ (or) } (2x + 1) = 0$$

$$\Rightarrow x = 3 \text{ (or) } x = -1/2$$

5) Solve $9x^2 - 6ax + (a^2 - b^2) = 0$ by factorization method?

Sol: Given $9x^2 - 6ax + (a^2 - b^2) = 0$

$$\Rightarrow 9x^2 - [3(a + b) + 3(a - b)]x + (a^2 - b^2) = 0$$

$$\Rightarrow 9x^2 - 3(a + b)x - 3(a - b)x + (a + b)(a - b) = 0$$

$$\Rightarrow 3x [3x - (a + b)] - (a - b) [3x - (a + b)] = 0$$

$$\Rightarrow [3x - (a + b)] [3x - (a - b)] = 0$$

$$\Rightarrow 3x - (a + b) = 0 \text{ (or) } 3x - (a - b) = 0$$

$$x = \frac{a+b}{3} \text{ (or) } x = \frac{a-b}{3}$$

6) The sum of a number and its reciprocal is $2\frac{1}{42}$. Find the number?

Sol: Let the number = x

Reciprocal of that number = $1/x$

Given that, $x + \frac{1}{x} = 2\frac{1}{42}$

$$\Rightarrow x + \frac{1}{x} = \frac{85}{42}$$

Multiplying both sides with "42x"

$$42x^2 + 42 = 85x$$

$$\Rightarrow 42x^2 + 42 - 85x = 0$$

$$\Rightarrow 42x^2 - 49x - 36x + 42 = 0$$

$$\Rightarrow 7x(6x - 7) - 6(6x - 7) = 0$$

$$\Rightarrow (6x - 7)(7x - 6) = 0$$

$$\Rightarrow (6x - 7) = 0 \text{ (or) } (7x - 6) = 0$$

$$\Rightarrow x = 7/6 \text{ (or) } x = 6/7$$

7) Find the roots of the quadratic equation $2x^2 - 7x + 3 = 0$, by using method of completing the square?

Sol: Given $2x^2 - 7x + 3 = 0$

Dividing both sides with "2"

$$\Rightarrow x^2 - \frac{7}{2}x + \frac{3}{2} = 0$$

$$\Rightarrow x^2 - \frac{7}{2}x = -\frac{3}{2}$$

$$\Rightarrow x^2 - 2.(x).\frac{7}{4} = -\frac{3}{2}$$

Adding both sides by $\left(\frac{7}{4}\right)^2$

$$\Rightarrow x^2 - 2.(x).\frac{7}{4} + \left(\frac{7}{4}\right)^2 = -\frac{3}{2} + \left(\frac{7}{4}\right)^2$$

$$\Rightarrow \left(x - \frac{7}{4}\right)^2 = -\frac{3}{2} + \frac{49}{16} = \frac{-24 + 49}{16} = \frac{25}{16} = \left(\frac{5}{4}\right)^2$$

$$\Rightarrow x - \frac{7}{4} = \sqrt{\left(\frac{5}{4}\right)^2} = \pm \frac{5}{4}$$

$$\Rightarrow x = \pm \frac{5}{4} + \frac{7}{4}$$

$$\Rightarrow x = \frac{5}{4} + \frac{7}{4} \text{ (or) } x = -\frac{5}{4} + \frac{7}{4} = \frac{12}{4} \text{ (or) } \frac{2}{4}$$

$$\Rightarrow x = 3 \text{ (or) } \frac{1}{2}$$

8) Find the roots of the equation $x + \frac{1}{x} = 3$ by using quadratic formula?

Sol: Given $x + \frac{1}{x} = 3$

Multiplying with 'x' on both sides

$$\Rightarrow x^2 + 1 = 3x$$

$$\Rightarrow x^2 - 3x + 1 = 0$$

Comparing with $ax^2 + bx + c = 0$, we get $a = 1$, $b = -3$ $c = 1$

$$\text{Discriminant (d)} = b^2 - 4ac = (-3)^2 - 4(1)(1) = 9 - 4 = 5 > 0$$

Since $d > 0$, we can find the real root of given equation.

$$\Rightarrow x = \frac{-b \pm \sqrt{b^2 - 4ac}}{2(1)}$$

$$\Rightarrow x = \frac{-(-3) \pm \sqrt{5}}{2(1)}$$

$$\Rightarrow \frac{3 \pm \sqrt{5}}{2}$$

$$\Rightarrow \frac{3 + \sqrt{5}}{2} \text{ (or)} \Rightarrow \frac{3 - \sqrt{5}}{2}$$

9) Find the values of k for the quadratic equation $kx(x - 2) + 6 = 0$. So that they have two real equal roots?

Sol: Given quadratic equation $kx(x - 2) + 6 = 0$

$$\Rightarrow kx^2 - 2kx + 6 = 0$$

Comparing with $ax^2 + bx + c = 0$, we get $a = k$, $b = -2k$, $c = 6$

Since the given quadratic has two equal real roots discriminant $(d) = 0$

$$\Rightarrow \text{i.e. } b^2 - 4ac = 0$$

$$\Rightarrow (-2k)^2 - 4(k)(6) = 0$$

$$\Rightarrow 4k^2 - 24k = 0$$

$$\Rightarrow 4k(k - 6) = 0$$

$$\Rightarrow k = 0 \text{ (or) } k - 6 = 0$$

$$\Rightarrow k = 0 \text{ (or) } k = 6$$

If $k = 0$ then the equation $0 \cdot x(x - 2) + 6 = 0 \Rightarrow 6 = 0$. This is not a quadratic equation. So $k \neq 0$.

$$\therefore K = 6$$

10) If -4 is a root of the quadratic equation $x^2 + px - 4 = 0$ and the quadratic equation $x^2 + px + k = 0$ has equal roots, find the value of k .

Sol: Given equations

$$x^2 + px - 4 = 0 \text{ ----(1)}$$

$$x^2 + px + k = 0 \text{ ----(2)}$$

-4 is a root of equation(1).

$$\text{i.e. } (-4)^2 + p(-4) - 4 = 0$$

$$\Rightarrow 16 - 4p - 4 = 0$$

$$\Rightarrow 12 - 4p = 0$$

$$\Rightarrow p = 3$$

Substitute $p = 3$ in equation (2) we get,

$$x^2 + 3x + k = 0 \text{ ----(3)}$$

Equation (3) has equal roots.

$$\text{Discriminant } b^2 - 4ac = 0$$

$$\Rightarrow (3)^2 - 4(1)(k) = 0$$

$$\Rightarrow 4k = 9$$

$$\Rightarrow k = 9/4$$

MULTIPLE CHOICE QUESTIONS

- 1) Which of the following is not a quadratic equation. [B]
 A) $(x - 2)^2 + 1 = 2x - 3$ B) $x(x + 1) + 8 = (x + 2)(x - 2)$
 C) $x(2x + 3) = x^2 + 1$ D) $(x + 2)^3 = x^3 - 4$
- 2) Which of the following is a quadratic equation? [A]
 A) $(x + 1)^2 = 2(x - 3)$ B) $(x - 2)(x + 1) = (x - 1)(x + 3)$
 C) $x^2 + 3x + 1 = (x - 2)^2$ D) $x^4 - 1 = 0$
- 3) The sum of a number and its reciprocal is $50/7$, then the number is [A]
 A) $1/7$ B) 5 C) $2/7$ D) $3/7$
- 4) The roots of the equation $3x^2 - 2\sqrt{6}x + 2 = 0$ are: [C]
 A) $\frac{2}{\sqrt{3}}, -\frac{2}{\sqrt{3}}$ B) $\frac{1}{\sqrt{3}}, -\frac{1}{\sqrt{3}}$ C) $\sqrt{\frac{2}{3}}, \sqrt{\frac{2}{3}}$ D) $\frac{1}{\sqrt{3}}, \frac{5}{\sqrt{3}}$
- 5) Which of the following equations has $1/5$ as a root? [A]
 A) $35x^2 - 2x - 1 = 0$ B) $2x^2 - 7x - 6 = 0$
 C) $10x^2 - 3x - 1 = 0$ D) $3x^2 - 2x - 1 = 0$
- 6) If $x^2 - 2x + 1 = 0$, then $x + 1/x = \dots$ then $k = \dots$ [B]
 A) 0 B) 2 C) 1 D) None
- 7) If 3 is a solution of $3x^2 + (k - 1)x + 9 = 0$, then $k = \dots$ [B]
 A) 11 B) -11 C) 13 D) -13
- 8) The roots of $x^2 - 2x - (r^2 - 1) = 0$ are [B]
 A) $1 - r, -r - 1$ B) $1 - r, r + 1$ C) $1, r$ D) $1 - r, r$
- 9) The sum of the roots of the equation $3x^2 - 7x + 11 = 0$ is [C]
 A) $11/3$ B) $-7/3$ C) $7/3$ D) $3/7$
- 10) The roots of the equation $\frac{x^2 - 8}{x^2 + 20} = \frac{1}{2}$ are [C]
 A) ± 3 B) ± 2 C) ± 6 D) ± 4

- 11) The roots of the quadratic equation $\frac{9}{x^2 - 27} = \frac{25}{x^2 - 11}$ are [C]
A) ± 3 B) ± 4 C) ± 6 D) ± 5
- 12) The roots of the equation $\sqrt{2x^2 + 9} = 9$ are [B]
A) $x = 6$ B) $x = \pm 6$ C) $x = -6$ D) 0
- 13) Which of the following equations has the product of its roots as 4? [A]
A) $x^2 + 4x + 4 = 0$ B) $x^2 + 4x - 4 = 0$
C) $-x^2 + 4x + 4 = 0$ D) $x^2 + 4x - 24 = 0$
- 14) The two roots of a quadratic equation are 2 and -1. The equation is [D]
A) $x^2 + 2x - 2 = 0$ B) $x^2 + x + 2 = 0$
C) $x^2 + x + 2 = 0$ D) $x^2 - x - 2 = 0$
- 15) If the sum of a quadratic equation are $3x^2 + (2k + 1)x - (k+5) = 0$, is equal to the product of the roots, then the value of k is..... [C]
A) 2 B) 3 C) 4 D) 5
- 16) The value of k for which 3 is a root of the equation $kx^2 - 7x + 3 = 0$ is [B]
A) -2 B) 2 C) 3 D) -3
- 17) If the difference of the roots of the quadratic equation $x^2 - ax + b$ is 1, then [C]
A) $a^2 - 4b = 0$ B) $a^2 - 4b = -1$
C) $a^2 - 4b = 1$ D) $a^2 - 4b = 4$
- 18) The quadratic equation whose one root $2 - \sqrt{3}$ is [A]
A) $x^2 - 4x + 1 = 0$ B) $x^2 + 4x - 1 = 0$
C) $x^2 - 4x - 1 = 0$ D) $x^2 - 2x - 3 = 0$
- 19) What is the condition that one root of the quadratic equation $ax^2 + bx + c$ is reciprocal of the other? [A]
A) $a = c$ B) $a = b$ C) $b = c$ D) $a + b + c = 0$

- 20) The roots of a quadratic equation $\frac{x}{p} = \frac{p}{x}$ are [**A**]
A) $\pm p$ B) $p, 2p$ C) $-p, 2p$ D) $-p, -2p$
- 21) If the roots of the equation $12x^2 + mx + 5 = 0$ are real and equal then **m** is equal to [**C**]
A) $8\sqrt{15}$ B) $2\sqrt{15}$ C) $4\sqrt{15}$ D) $10\sqrt{15}$
- 22) Which of the following equations has the equal roots? [**B**]
A) $x^2 + 6x + 5 = 0$ B) $x^2 - 8x + 16 = 0$
C) $6x^2 - x - 2 = 0$ D) $10x - \frac{1}{x} = 3$
- 23) If the equation $x^2 - 4x + 9$ has no real roots, then [**D**]
A) $a < 4$ B) $a \leq 4$ C) $a < 2$ D) $a > 4$
- 24) The discrimination of the quadratic equation $7\sqrt{3}x^2 + 10x - \sqrt{3} = 0$ is [**C**]
A) 142 B) $\frac{-10}{7\sqrt{3}}$ C) 184 D) 26
- 25) The value of $\sqrt{6 + \sqrt{6 + \sqrt{6 + \sqrt{6 + \dots}}}}$ is [**B**]
A) 4 B) 3 C) -2 D) 3.5

FILL IN THE BLANKS

- 1) Standard form of a quadratic equation is $(ax^2 + bx + c = 0, a \neq 0)$
- 2) The sum of a number and its reciprocal is $\frac{5}{2}$. This is represent as $(x + \frac{1}{x} = \frac{5}{2})$
- 3) “The sum of the squares of two consecutive natural numbers is 25”, is represent as $(x^2 + (x - 1)^2 = 25)$
- 4) If one root of a quadratic equation is $7 - \sqrt{3}$ then the other root is $(7 + \sqrt{3})$
- 5) The discriminant of $5x^2 - 3x - 2 = 0$ is (49)
- 6) The roots of the quadratic equation $x^2 - 5x + 6 = 0$ are $(2, 3)$
- 7) If $x = 1$ is a common root of the equations $ax^2 + ax + 3 = 0$ and $x^2 + x + b = 0$ then the value of ab is (3)
- 8) If the discriminant of the quadratic equation $ax^2 + bx + c = 0$ is zero, then the roots of the equation are (Real and equal)
- 9) The product of the roots of the quadratic equation $\sqrt{2}x^2 - 3x + 5\sqrt{2} = 0$ is (5)
- 10) The nature of the roots of a quadratic equation $4x^2 - 12x + 9 = 0$ is (real and equal)
- 11) If the equation $x^2 - bx + 1 = 0$ does not possess real roots, then
 $(b^2 - 4 < 0 \text{ (or) } b^2 < 4 \text{ (or) } -2 < b < 2)$
- 12) If the sum of the roots of the equation $x^2 - (k + 6)x + 2(2k - 1) = 0$ is equal to half of their product, then $k = \dots$ (7)
- 13) If one root of the equation $4x^2 - 2x + (\lambda - 4) = 0$ be the reciprocal of the other, then $\lambda = \dots$ (8)
- 14) If $\sin\alpha$ and $\cos\alpha$ are the roots of the equation $ax^2 + bx + c = 0$, then $b^2 = \dots$ $(a^2 + 2ac)$
- 15) If the roots of the equation $(a^2 + b^2)x^2 - 2b(a + c)x + (b^2 + c^2) = 0$ are equal, then $b^2 = \dots$ (ac)
- 16) The quadratic equation whose roots are $-3, -4$ is $(x^2 + 7x + 12 = 0)$
- 17) If $b^2 - 4ac < 0$ then the roots of quadratic equation $ax^2 + bx + c = 0$ are
 $(\text{Not real or imaginary})$

CHAPTER - 5

QUADRATIC EQUATIONS

Quadratic Equations: A quadratic equation in the variable x is an equation of the form $ax^2 + bx + c = 0$ where a, b, c are real numbers and $a \neq 0$

(Or)

Any equation of the form $P(x) = 0$ Where $P(x)$ is polynomial of degree 2 is a quadratic equation.

$ax^2 + bx + c = 0$ is called the standard form of the quadratic equation

$y = ax^2 + bx + c$ is called quadratic function

There are various uses of quadratic functions. Some of them are:

- i. When the rocket is fired upward then the height of the rocket is defined by a '**Quadratic Function**'.
- ii. Shapes of the satellite, reflecting mirror in a telescope lens of the eye glasses and orbit of the celestial objects are defined by the quadratic equation
- iii. The part of the projectile is defined by quadratic function.
- iv. When the breaks are applied to a vehicle, then the stopping point is calculated by using quadratic equation

A real number α is called a root of a quadratic equation $ax^2 + bx + c = 0$ if

$a\alpha^2 + b\alpha + c = 0$ we also say that $x = \alpha$ is a solution of the quadratic equation. or α satisfies the quadratic equation.

Ex: 2, 3 are roots of the quadratic equation $x^2 - 5x + 6 = 0$

The zeroes of the quadratic polynomial $ax^2 + bx + c$ and the roots of the quadratic equation $ax^2 + bx + c = 0$ are the same.

Any quadratic equation can have at most two roots.

Solution of a Quadratic Equation By Factorisation

If the quadratic equation $ax^2 + bx + c = 0$ can be written in the form

$(px + q)(rx + s) = 0$; $p \neq 0, r \neq 0$ then $-\frac{q}{p}$ and $-\frac{s}{r}$ will be the root of quadratic equation. Which are respectively the values of x obtained from $px + q = 0$ and $rx + s = 0$

Ex: $6x^2 - x - 2 = 0$

$$\Rightarrow (3x - 2)(2x + 1) = 0$$

The roots of $6x^2 - x - 2 = 0$ are the values of “ x ” for which

$$\Rightarrow (3x - 2)(2x + 1) = 0$$

$$\Rightarrow 3x - 2 = 0 \text{ or } 2x + 1 = 0$$

i.e $x = \frac{2}{3}$ or $x = -\frac{1}{2}$

\therefore The roots of $6x^2 - x - 2 = 0$ are $\frac{2}{3}$ and $-\frac{1}{2}$

To factorize a quadratic equation $ax^2 + bx + c = 0$ we find $p, q \in \mathbb{R}$ such that $p + q = b$ and $pq = ac$.

This process is called Factorising a quadratic equation by splitting its middle term.

Solution of a Quadratic Equation By Completing The Square

Let the quadratic equation be $ax^2 + bx + c = 0$, $a \neq 0$

Dividing throughout by a , we get

$$x^2 + \frac{b}{a}x + \frac{c}{a} = 0$$

Adding and Subtracting $\left(\frac{b}{2a}\right)^2$

$$x^2 + \frac{b}{a}x + \left(\frac{b}{2a}\right)^2 - \left(\frac{b}{2a}\right)^2 + \frac{c}{a} = 0$$

$$\left(x + \frac{b}{2a}\right)^2 - \frac{(b^2 - 4ac)}{4a^2} = 0$$

$$\left(x + \frac{b}{2a}\right)^2 = \frac{(b^2 - 4ac)}{4a^2}$$

$$x + \frac{b}{2a} = \frac{\pm\sqrt{b^2 - 4ac}}{2a}$$

$$x = \frac{-b \pm \sqrt{b^2 - 4ac}}{2a}$$

Thus if $b^2 - 4ac \geq 0$ then the roots of the quadratic equation $ax^2 + bx + c = 0$

are given by $\frac{-b \pm \sqrt{b^2 - 4ac}}{2a}$

Let $ax^2 + bx + c = 0$, $a \neq 0$ be a quadratic equation then $b^2 - 4ac$ is called the Discriminate of the quadratic equation.

If $b^2 - 4ac > 0$ then the roots of the quadratic equation $ax^2 + bx + c = 0$ are

given by $x = \frac{-b \pm \sqrt{b^2 - 4ac}}{2a}$

This is called quadratic formula to find the roots.

A quadratic equation $ax^2 + bx + c = 0$ has

- i. Two distinct real roots, if $b^2 - 4ac > 0$
- ii. Two equal real roots, if $b^2 - 4ac = 0$
- iii. No real roots, if $b^2 - 4ac < 0$

Roots of a quadratic equation are those points where the curve cuts the X-axis.

Case - 1: If $b^2 - 4ac > 0$

We get two distinct real roots $\frac{-b - \sqrt{b^2 - 4ac}}{2a}$, $\frac{-b + \sqrt{b^2 - 4ac}}{2a}$

In such case we get the following figures.

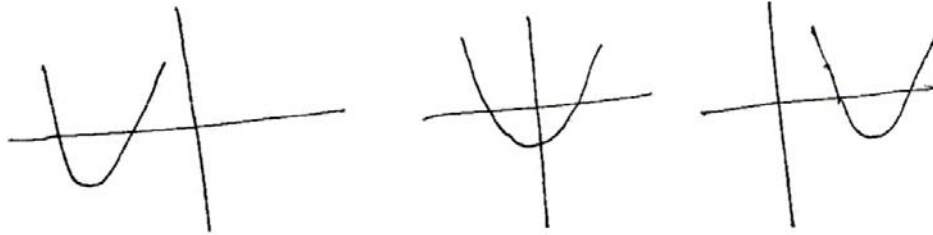

Figure shows that the curve of the quadratic equation cuts the X-axis at two distinct points.

Case - 2 : If $b^2 - 4ac = 0$

$$x = \frac{-b \pm 0}{2a}; x = \frac{-b}{2a}, \frac{-b}{2a}$$

In such case we get the following figures.



Figure shows that the curve of the quadratic equation touching X-axis at one point.

Case - 3 : If $b^2 - 4ac < 0$

There are no real roots. Roots are imaginary. In such case we get the following figures.

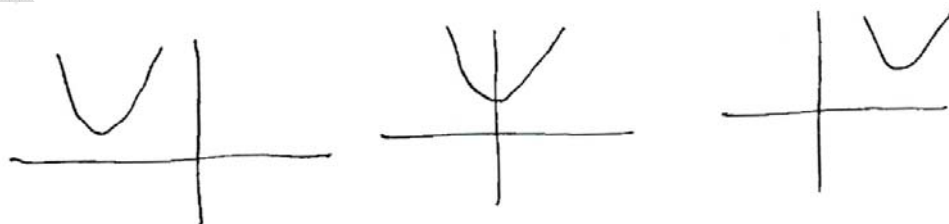

In this case graph neither intersects nor touches the X-axis at all. So there are no real roots.

Let $ax^2 + bx + c = 0$ be a given quadratic equation and α, β are the roots of given quadratic equation, then

$$\text{Sum of the roots} = \alpha + \beta = \frac{-b}{a} = \frac{-x \text{ Coefficient}}{x^2 \text{ Coefficient}}$$

$$\text{Product of the roots} = \alpha \beta = \frac{c}{a} = \frac{\text{Constant term}}{x^2 \text{ Coefficient}}$$

Quadratic equation whose roots are α, β is $x^2 - (\alpha + \beta)x + \alpha\beta = 0$

ESSAY EQUATIONS

1) Find the roots of the following quadratic equations by factorization

$$(i) x - \frac{1}{3x} = \frac{1}{6}$$

$$(ii) 3(x - 4)^2 - 5(x - 4) = 12$$

Sol:

$$(i) x - \frac{1}{3x} = \frac{1}{6}$$

$$\Rightarrow x - \frac{1}{3x} - \frac{1}{6} = 0 \Rightarrow \frac{18x^2 - 6 - 3x}{18x} = 0$$

$$18x^2 - 3x - 6 = 0$$

$$\Rightarrow 3(6x^2 - x - 2) = 0 \Rightarrow 6x^2 - x - 2 = 0$$

$$\Rightarrow 2x(3x - 2) + 1(3x - 2) = 0$$

$$\Rightarrow (3x - 2)(2x + 1) = 0$$

$$\Rightarrow 3x - 2 = 0 \text{ (or) } 2x + 1 = 0$$

$$\Rightarrow x = \frac{2}{3} \text{ (or) } x = -\frac{1}{2}$$

\therefore The roots of given quadratic equation are $\frac{2}{3}, -\frac{1}{2}$

$$(ii) 3(x - 4)^2 - 5(x - 4) = 12$$

$$\Rightarrow \text{Let } x - 4 = a$$

$$\Rightarrow 3a^2 - 9a + 4a - 12 = 0 \text{ } (\because 3 \times -12 = -36)$$

$$\Rightarrow 3a(a - 3) + 4(a - 3) = 0$$

$$\Rightarrow (a - 3)(3a + 4) = 0$$

$$\Rightarrow a = 3 \text{ (or) } a = -\frac{4}{3}$$

$$\Rightarrow \text{But } a = x - 4$$

$$\text{i.e. } x - 4 = 3 \Rightarrow x = 7$$

$$x - 4 = -\frac{4}{3} \Rightarrow x = -\frac{4}{3} + 4$$

$$\Rightarrow x = \frac{-4 + 12}{3} = \frac{8}{3}$$

The roots of given quadratic equation are $7, \frac{8}{3}$

2) Find two consecutive positive integers, sum of whose squares is 613.

Sol: Let the two consecutive positive integers be $x, x+1$

Given that sum of the squares of two consecutive integers is 613.

$$\text{i.e. } x^2 + (x + 1)^2 = 613$$

$$\Rightarrow x^2 + x^2 + 2x + 1 = 613$$

$$\Rightarrow 2x^2 + 2x + 1 - 613 = 0$$

$$\Rightarrow 2x^2 + 2x - 612 = 0$$

$$\Rightarrow 2(x^2 + x - 306) = 0 \Rightarrow x^2 + x - 306 = 0$$

$$(\because 1 \times -306 = -306 \text{ (} 18 \times -17 \text{)})$$

$$\Rightarrow x^2 + 18x - 17x - 306 = 0$$

$$\Rightarrow x(x + 18) - 17(x + 18) = 0$$

$$\Rightarrow (x + 18)(x - 17) = 0$$

$$\Rightarrow (x + 18) = 0 \text{ (or) } x - 17 = 0$$

$$\Rightarrow x = -18 \text{ (or) } x = 17$$

If x is positive, then $x = 17$.

If $x = 17$ then the consecutive positive integers are 17, 18.

3) The altitude of a right triangle is 7cm less than its base. If the hypotenuse is 13 cm; find the other two sides?

Sol: Let the base of a right angle triangle be 'x'.

Given that the altitude of a right triangle is 7 cm less than its base.

$$\text{Altitude (or) height} = h = x - 7$$

Given that hypotenuse = 13 cm

By pythagorus theorem

$$(\text{Hypotenuse})^2 = (\text{Base})^2 + (\text{Height})^2 \Rightarrow x^2 - 12x + 5x - 60 = 0$$

$$\Rightarrow (13)^2 = x^2 + (x - 7)^2$$

$$\Rightarrow x^2 + x^2 - 14x + 49 = 169$$

$$\Rightarrow 2x^2 - 14x - 120 = 0$$

$$\Rightarrow 2(x^2 - 7x - 60) = 0, \Rightarrow x^2 - 7x - 60 = 0$$

$$\Rightarrow x^2 - 12x + 5x - 60 = 0$$

$$\Rightarrow x(x - 12) + 5(x - 12) = 0$$

$$\Rightarrow (x - 12)(x + 5) = 0$$

$$\Rightarrow x = 12, -5$$

Length of base is always positive.

Length of base = 12 cm

Height (or) Altitude = $x - 7 = 12 - 7 = 5$ cm

- 4) **A cottage industry produces a certain number of pottery articles in a day. It was observed on a particular day that the cost of production of each article (in rupees) was 3 more than twice the number of articles produced on that day. If the total cost of production on that day was Rs. 90, find the number of articles produced and the cost of each article.**

Sol: Let the number of pottery articles produced by a cottage industry be 'x'.

Given that the cost of production of each article (in rupees) was 3 more than twice the number of articles produced on that day.

$$\therefore \text{Price of each article} = 2x + 3$$

$$\text{Total cost of articles} = \text{Rs. } 90$$

$$\text{i.e. } x(2x + 3) = 90 \Rightarrow 2x^2 + 3x - 90 = 0$$

$$\Rightarrow 2x^2 + 15x - 12x - 90 = 0$$

$$\Rightarrow x(2x + 15) - 6(2x + 15) = 0$$

$$\Rightarrow (x - 6)(2x + 15) = 0$$

$$\Rightarrow 2x + 15 = 0 \text{ (or) } x - 6 = 0$$

$$\Rightarrow x = -\frac{15}{2} \text{ (or) } x = 6$$

No of articles never be negative, So $x \neq -\frac{15}{2}$

$$\text{Price of each article} = 2x + 3 = 2(6) + 3 = \text{Rs. } 15$$

- 5) Find the dimensions of a rectangle whose perimeter is 28 meters and whose area is 40 square meters.

Sol: Let the length of a rectangle be 'x' meters i.e $l = x$

$$\text{Perimeter of a rectangle} = 2(l + b) = 28\text{m (Given)}$$

$$\Rightarrow 2(x + b) = 28 \Rightarrow x + b = 14 \Rightarrow b = 14 - x$$

Given that area of a rectangle = lb

$$\Rightarrow x(14 - x) = 40 \text{ sq.m}$$

$$\Rightarrow 14x - x^2 = 40$$

$$\Rightarrow 14x - x^2 - 40 = 0$$

$$\Rightarrow x^2 - 14x + 40 = 0$$

$$\Rightarrow x^2 - 10x - 4x + 40 = 0$$

$$\Rightarrow x(x - 10) - 4(x - 10) = 0$$

$$\Rightarrow (x - 10)(x - 4) = 0$$

$$\Rightarrow x = 10 \text{ (or) } x = 4$$

If the length $x = 10\text{m}$, then the width $b = 14 - x = 14 - 10 = 4 \text{ m}$

If the length $x = 4 \text{ cm}$, then width $b = 14 - x = 14 - 4 = 10 \text{ m}$

The dimensions of rectangle are 10m, 4m.

- 6) **The base of a triangle is 4 cm, longer than its altitude. If the area of the triangle is 48 sq. cm then find its base and altitude.**

Sol: Let the height of the triangle = x cm

Given that the base of a triangle is 4 cm, longer than its altitude (height)

i.e Base = $(x + 4)$ cm

$$\text{Area of the triangle} = \frac{1}{2}bh = 48 \text{ sq.cm}$$

$$\Rightarrow \frac{1}{2} \times (x + 4) x = 48$$

$$\Rightarrow x^2 + 4x = 96$$

$$\Rightarrow x^2 + 4x - 96 = 0$$

$$\Rightarrow x^2 + 12x - 8x - 96 = 0$$

$$\Rightarrow x(x + 12) - 8(x + 12) = 0$$

$$\Rightarrow (x + 12)(x - 8) = 0$$

$$x + 12 = 0 \text{ (or) } x - 8 = 0$$

$$x = -12 \text{ (or) } x = 8$$

Height of the triangle never be negative.

Height $x = 8$ cm

Base = $x + 4 = 8 + 4 = 12$ cm

- 7) Two trains leave a railway station at the same time. The first train travels towards West and the second train towards north. The first train travels 5km/hr faster than the second train. If after two hours they are 50 km apart. Find average speed of each train?

Sol: Let the speed of second train = x km/hour

Speed of first train = $x + 5$ km/hour

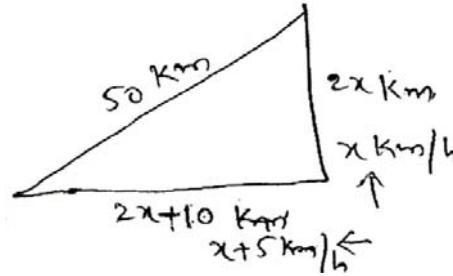

After two hours distance travelled by first train = $2(x + 5) = 2x + 10$ km

Distance travelled by second train = $2x$ km.

Distance between two trains after two hours = 50 km

By pythagoras theorem

$$(2x + 10)^2 + (2x)^2 = 50^2$$

$$\Rightarrow 4x^2 + 40x + 100 + 4x^2 = 2500$$

$$8x^2 + 40x - 2400 = 0 \Rightarrow 8(x^2 + 5x - 300) = 0$$

$$\Rightarrow x^2 + 20x - 15x - 300 = 0$$

$$\Rightarrow x(x + 20) - 15(x + 20) = 0$$

$$\Rightarrow (x + 20)(x - 15) = 0$$

$$\Rightarrow x = -20, x = 15$$

Speed of the train never be negative

Speed of second train = 15 km/hour

Speed of first train = $x + 5 = 15 + 5 = 20$ km/hour

- 8) In a class of 60 students, each boy contributed rupees equal to the number of girls and each girl contributes rupees equal to the number of boys. If the total money then collected was Rs. 1600. How many boys are there in the class?**

Sol: Total number of students in a class = 60

Let the number of boys = x

Then the number of girls = $60 - x$

Each boy contributed rupees equal to the number of girls and each girl contributed rupees equal to the number of boys and the total money collected was Rs. 1600.

$$\text{i.e } x(60 - x) + x(60 - x) = 1600$$

$$\Rightarrow 2x(60 - x) = 1600$$

$$\Rightarrow x(60 - x) = 800$$

$$\Rightarrow 60x - x^2 - 800 = 0$$

$$\Rightarrow x^2 - 60x + 800 = 0$$

$$\Rightarrow x^2 - 20x - 40x + 800 = 0$$

$$\Rightarrow x(x - 20) - 40(x - 20) = 0$$

$$\Rightarrow (x - 20)(x - 40) = 0$$

$$\Rightarrow x = 20 \text{ (or) } x = 40$$

Number of boys in the class room = 20 or 40

- 9) A motor boat heads upstream a distance of 24km on a river whose current is running at 3km per hour. The trip up and back takes 6 hours. Assuming that the motor boat maintained a constant speed, what is its speed?**

Sol: Let the speed of a motor boat = x km/hr

Speed of stream = 3 km/hour

The distance of the river = 24 km

The speed of the boat in upstream = $(x - 3)$ km/h

The speed of the boat in downstream = $x + 3$ km/h

Given that total time taken = 6 hours

$$\text{i.e. } \frac{24}{x + 3} + \frac{24}{x - 3} = 6$$

$$\Rightarrow 24(x - 3) + 24(x + 3) = 6(x + 3)(x - 3)$$

$$6[4(x - 3) + 4(x + 3)] = 6(x + 3)(x - 3)$$

$$4x - 12 + 4x + 12 = x^2 - 9$$

$$x^2 - 8x - 9 = 0$$

$$\Rightarrow x^2 - 9x + x - 9 = 0$$

$$\Rightarrow x(x - 9) + 1(x - 9) = 0$$

$$\Rightarrow (x - 9)(x + 1) = 0$$

$$\Rightarrow x = 9, x = -1$$

Speed of the boat never be negative.

Speed of boat in still water = 9 km/hour.

10) Solve the equations by completing the square.

i. $5x^2 - 7x - 6 = 0$

ii. $4x^2 + 4\sqrt{3}x + 3 = 0$

Sol: (i) Given quadratic equation $5x^2 - 7x - 6 = 0$, dividing with 5 on both sides.

$$x^2 - \frac{7}{5}x - \frac{6}{5} = 0$$

$$\Rightarrow x^2 - \frac{7}{5}x = \frac{6}{5}$$

$$\Rightarrow x^2 - 2(x)\left(\frac{7}{10}\right) = \frac{6}{5} \left(\because 2\left(\frac{7}{10}\right) = \frac{7}{5}\right)$$

Adding $\left(\frac{7}{10}\right)^2$, on both sides

$$\Rightarrow x^2 - 2(x)\left(\frac{7}{10}\right) + \left(\frac{7}{10}\right)^2 = \frac{6}{5} + \left(\frac{7}{10}\right)^2$$

$$\Rightarrow \left(x - \frac{7}{10}\right)^2 = \frac{6}{5} + \frac{49}{100} \left(\because x^2 - 2xy + y^2 = (x - y)^2\right)$$

$$\Rightarrow \left(x - \frac{7}{10}\right)^2 = \frac{120 + 49}{100} = \frac{169}{100}$$

$$\Rightarrow \left(x - \frac{7}{10}\right)^2 = \left(\frac{13}{10}\right)^2$$

$$\Rightarrow x - \frac{7}{10} = \pm \frac{13}{10} \left(\because x^2 = a^2 \Rightarrow x = \pm a\right)$$

$$\Rightarrow x = \pm \frac{13}{10} + \frac{7}{10}$$

$$= \frac{13}{10} + \frac{7}{10} \text{ (or) } -\frac{13}{10} + \frac{7}{10}$$

$$= \frac{20}{10} \text{ (or) } \frac{-6}{10} = 2 \text{ (or) } -\frac{3}{5}$$

(ii) Given quadratic equation $4x^2 + 4\sqrt{3}x + 3 = 0$

Dividing on both sides by 4, we get $x^2 + \sqrt{3}x + \frac{3}{4} = 0$

$$\Rightarrow x^2 + \sqrt{3}x = -\frac{3}{4}$$

$$\Rightarrow x^2 + 2(x)\left(\frac{\sqrt{3}}{2}\right) = -\frac{3}{4} \left(\because \sqrt{3} = 2\left(\frac{\sqrt{3}}{2}\right)\right)$$

Adding $\left(\frac{\sqrt{3}}{2}\right)^2$ on both sides, we get Adding $\left(\frac{\sqrt{3}}{2}\right)^2$ on both sides, we get

$$\Rightarrow x^2 + 2(x)\left(\frac{\sqrt{3}}{2}\right) + \left(\frac{\sqrt{3}}{2}\right)^2 = -\frac{3}{4} + \left(\frac{\sqrt{3}}{2}\right)^2 = -\frac{3}{4} + \frac{3}{4}$$

$$\Rightarrow \left(x + \frac{\sqrt{3}}{2}\right)^2 = 0$$

$$\Rightarrow x + \frac{\sqrt{3}}{2} = 0 \Rightarrow x = -\frac{\sqrt{3}}{2}$$

11) Find the roots of the following quadratic equations, if they exist, using the quadratic formula.

i. $2x^2 - 2\sqrt{2}x + 1 = 0$

ii. $x + \frac{1}{x} = 3 \ (x \neq 0)$

Sol:

(i) Given quadratic equation $2x^2 - 2\sqrt{2}x + 1 = 0$

Compare $ax^2 + bx + c = 0$; $a = 2$, $b = -2\sqrt{2}$, $c = 1$

$$\text{So, } b^2 - 4ac = (-2\sqrt{2})^2 - 4(2)(1) = 8 - 8 = 0$$

Since $b^2 - 4ac \geq 0$, the roots are exist.

$$\therefore x = \frac{-b \pm \sqrt{b^2 - 4ac}}{2a} = \frac{-(-2\sqrt{2}) \pm \sqrt{0}}{2(2)} = \frac{2\sqrt{2}}{4} = \frac{\sqrt{2}}{2} = \frac{1}{\sqrt{2}}$$

So the roots are $\frac{1}{\sqrt{2}}$, $\frac{1}{\sqrt{2}}$

(ii)

$$\text{Given that } x + \frac{1}{x} = 3$$

$$\Rightarrow \frac{x^2 + 1}{x} = 3 \Rightarrow x^2 + 1 = 3x \Rightarrow x^2 - 3x + 1 = 0$$

Compare with $ax^2 + bx + c = 0$, we get $a = 1$, $b = -3$, $c = 1$

$$b^2 - 4ac = (-3)^2 - 4(1)(1) = 9 - 4 = 5$$

$$\therefore x = \frac{-b \pm \sqrt{b^2 - 4ac}}{2a} = \frac{-(-3) \pm \sqrt{(-3)^2 - 4(1)(1)}}{2(1)}$$

$$x = \frac{3 \pm \sqrt{9 - 4}}{2} = \frac{3 \pm \sqrt{5}}{2}$$

So the roots are $\frac{3 + \sqrt{5}}{2}$ and $\frac{3 - \sqrt{5}}{2}$

12) Find the roots of the following quadratic equations?

i. $\frac{1}{x} - \frac{1}{x-2} = 3, (x \neq 0, 2)$

ii. $\frac{1}{x+4} - \frac{1}{x-7} = \frac{11}{30}, (x \neq -4, 7)$

Sol:

(i) Given $\frac{1}{x} - \frac{1}{x-2} = 3$

Multiplying the equation by $x(x-2)$ we get

$$(x-2) - x = 3x(x-2)$$

$$\Rightarrow 3x(x-2) = -2$$

$$3x^2 - 6x = -2 \Rightarrow 3x^2 - 6x + 2 = 0$$

Which is a quadratic equation compare with $ax^2 + bx + c = 0$

$$a = 3, b = -6, c = 2$$

$$\text{So, } b^2 - 4ac = (-6)^2 - 4(3)(2) = 36 - 24 = 12 > 0$$

$$\therefore x = \frac{-b \pm \sqrt{b^2 - 4ac}}{2a} = \frac{-(-6) \pm \sqrt{12}}{2(3)}$$

$$x = \frac{6 \pm 2\sqrt{3}}{6} = \frac{2(3 \pm \sqrt{3})}{6} = \frac{(3 \pm \sqrt{3})}{3}$$

$$\text{So the roots are } \frac{3+\sqrt{3}}{3} \text{ and } \frac{3-\sqrt{3}}{3}$$

(ii) Given $\frac{1}{x+4} - \frac{1}{x-7} = \frac{11}{30}$, ($x \neq -4, 7$)

Multiplying the equation by $30(x+4)(x-7)$, we get

$$30(x-7) - 30(x+4) = 11(x+4)(x-7)$$

$$\Rightarrow 30x - 210 - 30x - 120 = 11(x^2 - 7x + 4x - 28)$$

$$\Rightarrow -330 = 11(x^2 - 3x - 28)$$

$$\Rightarrow x^2 - 3x - 28 + 30 = 0$$

$$\Rightarrow x^2 - 3x + 2 = 0$$

$$\Rightarrow x^2 - 2x - x + 2 = 0$$

$$\Rightarrow x(x-2) - 1(x-2) = 0$$

$$\Rightarrow (x-2)(x-1) = 0$$

$$\Rightarrow x-2 = 0 \text{ (or) } x-1 = 0$$

$$\Rightarrow x = 2 \text{ (or) } 1$$

The roots of the given equation are 1 (or) 2

13) The sum of the reciprocals of Rehman's ages, (in years) 3 years ago and 5 years from now is $\frac{1}{3}$. Find his present age.

Sol: Let the present age of Rehman = x years

3 years ago of Rehman = $x - 3$ years

After 5 years, the age of Rehman = $x + 5$ years

Given that the sum of the reciprocals of Rehman's ages, 3 years ago and 5 years from now is $\frac{1}{3}$.

$$\text{i.e. } \frac{1}{x-3} + \frac{1}{x+5} = \frac{1}{3}$$

Multiplying with $3(x-3)(x+5)$, we get

$$\Rightarrow 3(x+5) + 3(x-3) = (x-3)(x+5)$$

$$\Rightarrow 3x + 15 + 3x - 9 = x^2 + 5x - 3x - 15$$

$$\Rightarrow 6x + 6 = x^2 + 2x - 15$$

$$\Rightarrow x^2 + 2x - 15 - 6x - 6 = 0$$

$$\Rightarrow x^2 - 4x - 21 = 0$$

$$\Rightarrow x^2 - 7x + 3x - 21 = 0$$

$$\Rightarrow x(x-7) + 3(x-7) = 0$$

$$\Rightarrow (x-7)(x+3) = 0$$

$$\Rightarrow (x-7) = 0 \text{ (or) } (x+3) = 0$$

$$\Rightarrow x = 7 \text{ (or) } x = -3$$

But age is not negative.

\therefore Present age of Rehman = 7 years.

- 14) In a class test, the sum of Moulika's marks in mathematics and English is 30. If she got 22 marks more in mathematics and 3 marks less in English, the product of her marks would have been 210. Find her marks in the two subjects?**

Sol: Sum of Moulika's marks in Mathematics and English is 30.

Let the marks in Maths = x

Then the marks in English = $30 - x$

If she got 2 marks more in Maths, and 3 marks less in English, the product of marks = 210.

$$\text{i.e. } (x+2)(30-x-3) = 210$$

$$\Rightarrow (x + 2)(27 - x) = 210$$

$$\Rightarrow 27x - x^2 + 54 - 2x - 210 = 0$$

$$\Rightarrow -x^2 + 25x - 156 = 0$$

$$\Rightarrow x^2 - 25x + 156 = 0$$

$$\Rightarrow x^2 - 13x - 12x + 156 = 0 \quad (\because 1 \times 156 = 156 \rightarrow -13 \times -12)$$

$$\Rightarrow x(x - 13) - 12(x - 13) = 0$$

$$\Rightarrow (x - 13)(x - 12) = 0$$

$$\Rightarrow (x - 13) = 0 \text{ (or) } (x - 12) = 0$$

$$\Rightarrow x = 13 \text{ (or) } x = 12$$

If marks in Maths $x = 13$, then marks in English $= 30 - x = 30 - 13 = 17$

If marks in Maths $x = 12$, then marks in English $= 30 - 12 = 18$

15) The diagonal of a rectangular field is 60 meters more than the shorter side. If the longer side is 30 meters more than the shorter side, find the sides of the field?

Sol: Let the length of the shorter side (breadth) = x meters.

Then the length of longer side = $x + 30$ meters (Given)

The length of diagonal = $x + 60$ (Given)

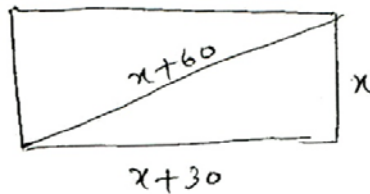

By pythagorus theorem

$$(x+60)^2 = (x+30)^2 + x^2$$

$$\Rightarrow x^2 + 120x + 3600 = x^2 + 60x + 900 + x^2$$

$$\Rightarrow x^2 + 60x + 900 - 120x - 3600 = 0$$

$$\Rightarrow x^2 - 60x - 2700 = 0$$

$$\Rightarrow x^2 - 90x + 30x - 2700 = 0 \quad (\because 1 \times -270 = -270)$$

$$\Rightarrow x(x - 90) + 30(x - 90) = 0$$

$$\Rightarrow (x - 90)(x + 30) = 0$$

$$\Rightarrow x = 90 \text{ (or) } x = -30$$

Length of the shorter side (x) never be negative.

Length of the shorter side = 90m

Length of longer side = $90 + 30 = 120\text{m}$

Length of diagonal = $90 + 60 = 150\text{ m}$

16) The difference of squares of two numbers is 180. The square of the smaller number is 8 times the larger number. Find the two numbers?

Sol: Let the larger number = x

Square of the larger number = x^2

Square of the smaller number = 8 times the larger number (Given)

$$= 8x$$

Given that difference of squares of two numbers is 180

$$\text{i.e. } x^2 - 8x = 180$$

$$\Rightarrow x^2 - 8x - 180 = 0$$

$$\Rightarrow x^2 - 18x + 10x - 180 = 0$$

$$\Rightarrow x(x - 18) + 10(x - 18) = 0$$

$$\Rightarrow (x - 18)(x + 10) = 0$$

$$\Rightarrow (x - 18) = 0 \text{ (or) } (x + 10) = 0$$

$$\Rightarrow x = 18 \text{ (or) } -10$$

\therefore The larger number $x = 18$ ($x \neq -10$)

The square of smaller number = $8 \times x = 8 \times 18 = 144$

The smaller number = $\sqrt{144} = \pm 12$

The two numbers are 18 and 12 (or) 18 and -12

17) A train travels 360 km at a uniform speed. If the speed had been 5km/h more, it would have taken 1 hour less for the same journey. Find the speed of the train?

Sol: The distance travelled by a train = 360 km

Let the speed of the train = x km/h

If the speed of the train increased 5 km/h, then the speed of the train = (x + 5) km/h

The time taken by the train, to cover 360 km distance with the speed x km/h is $\frac{360}{x}$.

The time taken by the train, to cover 360 km distance with the speed x + 5 km/h is $\frac{360}{x+5}$.

Difference between the two timings = 1 hour

$$\text{i.e. } \frac{360}{x} - \frac{360}{x+5} = 1$$

Multiplying with x (x + 5), we get

$$\Rightarrow 360(x + 5) - 360x = x(x + 5)$$

$$\Rightarrow 360x + 1800 - 360x = x^2 + 5x$$

$$\Rightarrow x^2 + 5x - 1800 = 0$$

$$\Rightarrow x^2 + 45x - 40x - 1800 = 0$$

$$\Rightarrow x(x + 45) - 40(x + 45) = 0$$

$$\Rightarrow (x + 45)(x - 40) = 0$$

$$\Rightarrow (x - 40) = 0 \text{ (or) } (x + 45) = 0$$

$$\Rightarrow x = 40 \text{ (or) } x = -45$$

\therefore Speed of the train x = 40 km/h (x = -45 net negative)

- 18) Two water taps together can fill a tank in $9\frac{3}{8}$ hours. The tap of larger diameter takes 10 hours less than the smaller one to fill the tank separately. Find the time in which each tap can separately fill the tank.

Sol: Total time takes by two water taps together can fill a tank

$$= 9\frac{3}{8} = \frac{75}{8} \text{ Hours}$$

The part of the tank filled by the two taps together in 1 hour is

$$= \frac{1}{\frac{75}{8}} = \frac{8}{75}$$

Time taken by the smaller diameter tap to fill the tank = x hours.

The tap of larger diameter takes 10 hours less than the smaller one to fill the tank.

i.e The time taken by the larger diameter tap to fill the tank = x – 10 hours

Part of the tank filled by the smaller diameter tap in 1 hour = $\frac{1}{x}$

Part of the tank filled by the larger diameter tap in 1 hour = $\frac{1}{x-10}$.

$$\text{But } \frac{1}{x} + \frac{1}{x-10} = \frac{8}{75} \text{ (From the problem)}$$

Multiplying with $75x(x-10)$ on both sides

$$\Rightarrow 75(x-10) + 75x = 8(x)(x-10)$$

$$\Rightarrow 75x - 750 + 75x = 8x^2 - 80x$$

$$\Rightarrow 8x^2 - 80x - 150x + 750 = 0$$

$$\Rightarrow 8x^2 - 230x + 750 = 0$$

$$\Rightarrow 8x^2 - 200x - 30x + 750 = 0$$

$$\Rightarrow 8x(x-25) - 30(x-25) = 0$$

$$\Rightarrow (x-25)(8x-30) = 0$$

$$\Rightarrow (8x - 30) = 0 \text{ (or) } (x - 25) = 0$$

$$\Rightarrow x = 30/8 = 15/4 \text{ (or) } x = 25$$

$$x \neq \frac{15}{4} \text{ (The big tap takes 10 hours less than the small tap)}$$

$$\therefore x = 25 \text{ hours}$$

Time taken by the smaller diameter tap to fill the tank separately = 25 hours

Time taken by the larger diameter tap to fill the tank separately

$$= x - 10$$

$$= 25 - 10$$

$$= 15 \text{ hours.}$$

- 19) An express train takes 1 hour less than a passenger train to travel 132 km between Mysore and Bangalore (Without taking into consideration the time they stop at intermediate stations). If the Average Speed of the express train is 11 km/h more than that of the passenger train, find the average speed of the two trains.**

Sol: Let the speed of passenger train = x km/h.

Then the speed of express train = $x + 11$ km/h

The distance travelled by two trains = 132 km.

Difference time between the two trains = 1 hour

$$\text{i.e. } \frac{132}{x} - \frac{132}{x+11} = 1$$

Multiplying with $x(x + 11)$ on both sides we get,

$$\Rightarrow 132(x + 11) - 132x = x(x + 11)$$

$$\Rightarrow 132x + 1452 - 132x = x^2 + 11x$$

$$\Rightarrow x^2 + 11x - 1452 = 0$$

$$\Rightarrow x^2 + 44x - 33x - 1452 = 0$$

$$\Rightarrow x(x + 44) - 33(x + 44) = 0$$

$$\Rightarrow (x + 44)(x - 33) = 0$$

$$\Rightarrow (x + 44) = 0 \text{ (or) } (x - 33) = 0$$

$$\Rightarrow x = -44 \text{ (or) } x = 33$$

Speed of the passenger train = 33 km/h ($x \neq -44$ not negative)

Speed of the express train = $x + 11 = 33 + 11 = 44$ km/h

20) Sum of the areas of two squares is 468m^2 . If the difference of their perimeters is 24m, find the sides of the two squares.

Sol: Let the side of the big square = x m.

Then the perimeter of the big square = $4x$ m.

Difference of the two squares perimeters = 24m.

The perimeter of the small square = $4x - 24$

$$\text{Side of the small square} = \frac{4x - 24}{4} = x - 6$$

Area of the big square = x^2

Area of the small square = $(x - 6)^2$

Given that sum of the areas of two squares is 468 m^2

$$\Rightarrow x^2 + (x - 6)^2 = 468$$

$$\Rightarrow x^2 + x^2 - 12x + 36 = 468$$

$$\Rightarrow 2x^2 - 12x + 36 - 468 = 0$$

$$\Rightarrow 2x^2 - 12x - 432 = 0$$

$$\Rightarrow x^2 - 6x - 216 = 0$$

$$\Rightarrow x^2 - 18x + 12x - 216 = 0$$

$$\Rightarrow x(x - 18) + 12(x - 18) = 0$$

$$\Rightarrow (x - 18)(x + 12) = 0$$

$$\Rightarrow (x - 18) = 0 \text{ (or) } (x + 12) = 0$$

$$\Rightarrow X = 18 \text{ (or) } x = -12$$

Side of the big square $x = 18$ m ($x \neq -12$ Not Negative)

Side of the small square $= x - 6 = 18 - 6 = 12$ m.

- 21) A ball is thrown vertically upward from the top of the building 96 feet tall with an initial velocity 80 m/second. The distance 's' of the ball from the ground after 't' seconds is $s = 96 + 80t - 16t^2$. After how many seconds does the ball strike the ground?**

Sol: Let the ball strike the ground at 't' sec.

Distance between the ball and the ground after 't' secs is '0'.

Given that the distance 's' of the ball from the ground after 't' seconds is

$$s = 96 + 80t - 16t^2$$

$$\text{i.e } \Rightarrow 96 + 80t - 16t^2 = 0$$

$$\Rightarrow -16(t^2 - 5t - 6) = 0$$

$$\Rightarrow (t^2 - 5t - 6) = 0$$

$$\Rightarrow t^2 - 6t + t - 6 = 0$$

$$\Rightarrow t(t - 6) + 1(t - 6) = 0$$

$$\Rightarrow (t + 1) = 0 \text{ (or) } (t - 6) = 0$$

$$\Rightarrow t = -1 \text{ (or) } t = 6$$

Time, 't' never be negative, i.e $t \neq -1$

$$\therefore t = 6$$

After 6 seconds the ball strike the ground.

- 22) If a polygon of 'n' sides has $\frac{1}{2}n(n-3)$ diagonal. How many sides will a polygon having 65 diagonals? Is there a problem with a 50 diagonals?**

Sol: Given that No. of diagonals of a polygon of 'n' sides $\frac{1}{2}n(n-3)$

Number of diagonals of a given polygon = 65

$$\frac{1}{2}n(n-3) = 65$$

$$\Rightarrow n(n-3) = 65 \times 2 = 130$$

$$\Rightarrow n^2 - 3n - 130 = 0$$

$$\Rightarrow n^2 - 13n + 10n - 130 = 0$$

$$\Rightarrow n(n-13) + 10(n-13) = 0$$

$$\Rightarrow (n-13)(n+10) = 0$$

$$\Rightarrow (n-13) = 0 \text{ (or) } (n+10) = 0$$

$$\Rightarrow n = 13 \text{ (or) } n = -10$$

No. of sides are not negative

\therefore Number of sides of a given polygon = 13

To check there is a polygon with 50 diagonals

$$\text{i.e. } \frac{1}{2}n(n-3) = 50$$

$$\Rightarrow n(n-3) = 100$$

$$\Rightarrow n^2 - 3n - 100 = 0$$

Compare with $ax^2 + bx + c = 0$, $a = 1$, $b = -3$, $c = -100$

$$b^2 - 4ac = (-3)^2 - 4(1)(-100) = 9 + 400 = 409$$

$$n = \frac{-b \pm \sqrt{b^2 - 4ac}}{2a}$$

$$n = \frac{-(-3) \pm \sqrt{409}}{2(1)}$$

$$n = \frac{3 \pm \sqrt{409}}{2}$$

Since n is not a natural number (countable number)

\therefore We can't find the sides of the polygon.

∴ There can't be a polygon with 50 diagonals.

23) Find the discriminant of the following quadratic equations and hence find the nature of its roots. Find them, if they are real?

i. $3x^2 - 2x + 1/3 = 0$

ii. $2x^2 - 3x + 5 = 0$

Sol:

i. Given quadratic equation $3x^2 - 2x + 1/3 = 0$.

Compare with $ax^2 + bx + c = 0$, $a = 3$, $b = -2$, $c = 1/3$

Discriminant = $b^2 - 4ac = (-2)^2 - 4(3)(1/3) = 4 - 4 = 0$

The roots are

$$n = \frac{-b \pm \sqrt{b^2 - 4ac}}{2a}$$

$$n = \frac{-(-2) \pm \sqrt{0}}{2(3)}$$

$$n = \frac{2}{6} = \frac{1}{3}$$

The two equal roots are $\frac{1}{3}, \frac{1}{3}$

ii. Given quadratic equation $2x^2 - 3x + 5 = 0$.

Compare with $ax^2 + bx + c = 0$, $a = 2$, $b = -3$, $c = 5$

∴ Discriminant = $b^2 - 4ac = (-3)^2 - 4(2)(5) = 9 - 40 = -31 < 0$

So, the given equation has no real roots.

24) It is possible to design a rectangular mango grove whose length is twice its breadth, and the area is 800 m²? If so, find its length and breadth?

Sol: Let the breadth of the rectangular mango grove = x m.

∴ Given that length is twice its breadth.

Length = 2x m.

Area = l × b = 2x × x = 800

$$\Rightarrow 2x^2 = 800$$

$$\Rightarrow x^2 = \frac{800}{2} = 400$$

$$\Rightarrow x^2 - 400 = 0 \text{ -----(1)}$$

Compare with $ax^2 + bx + c = 0$, $a = 1$, $b = 0$, $c = -400$

$$\therefore \text{Discriminant} = b^2 - 4ac = (0)^2 - 4(1)(-400) = 1600 > 0$$

(Discriminant > 0)

i.e. ∴ It is possible to find breadth (x), and length (2x).

∴ It is possible to design a rectangular mango grove.

From equation (1)

$$x = \frac{-b \pm \sqrt{b^2 - 4ac}}{2a}$$

$$x = \frac{0 \pm \sqrt{1600}}{2(1)}$$

$$\Rightarrow x = \frac{40}{2} = 20$$

∴ Breadth (x) = 20m, Length (2x) = 2 × 20 = 40 m.

- 25) The sum of the ages of two friends is 25 years. Four years ago, the product of their ages in years was 48. Is the situation possible? If so, determine their present ages?**

Sol: Let the ages of two friends be x , $20 - x$

(Given that sum of the ages of two friends is 20 years)

4 years ago their ages are $x - 4$; $20 - x - 4$

Given that $(x - 4)(20 - x - 4) = 48$

$$\Rightarrow (x - 4)(16 - x) = 48$$

$$\Rightarrow 16x - x^2 - 64 + 4x = 48$$

$$\Rightarrow -x^2 + 20x - 64 - 48 = 0$$

$$\Rightarrow x^2 - 20x + 112 = 0 \text{ -----(1)}$$

Compare with $ax^2 + bx + c = 0$, $a = 1$, $b = -20$, $c = 112$

$$\therefore \text{Discriminant} = b^2 - 4ac = (-20)^2 - 4(1)(112) = 400 - 448 = -48 < 0$$

(Discriminant < 0)

It is not possible to find real root for equation (1)

\therefore The situation is not possible.

- 26) It is possible to design a rectangular park of perimeter 80 m. and area 400m^2 ? If so, find its length and breadth?**

Sol: Let the length and breadth be l and b .

Given that perimeter 80m, and area 400m^2 .

$$\text{i.e. } 2(l + b) = 80$$

$$\Rightarrow l + b = 40 \text{ ---- (1)}$$

$$\Rightarrow lb = 400 \text{ ----- (2)}$$

Let the breadth of the rectangle be $(b) = x$ m.

Then from equation (1) we get $l + x = 40 \Rightarrow l = 40 - x$

From equation (2) $lb = 400$

$$\Rightarrow (40 - x)(x) = 400$$

$$\Rightarrow 40x - x^2 = 400$$

$$\Rightarrow 40x - x^2 - 400 = 0$$

$$\Rightarrow x^2 - 40x + 400 = 0 \text{ -----(3)}$$

Compare with $ax^2 + bx + c = 0$, $a = 1$, $b = -40$, $c = 400$

$$\therefore \text{Discriminant} = b^2 - 4ac = (-40)^2 - 4(1)(400) = 1600 - 1600 = 0$$

Since discriminant = 0, we can find real roots of equation (3)

i.e. \therefore It is possible to design a rectangular park.

From equation (3)

$$x = \frac{-b \pm \sqrt{b^2 - 4ac}}{2a}$$

$$x = \frac{-(-40) \pm \sqrt{0}}{2(1)}$$

$$\Rightarrow x = \frac{40}{2} = 20$$

$$\therefore \text{Breadth (x)} = 20\text{m}$$

$$\text{Length} = 40 - x = 40 - 20 = 20 \text{ m.}$$

27) Solve the following quadratic equations by factorization method.

i. $4x^2 - 2(a^2 + b^2)x + a^2 b^2 = 0$

ii. $9x^2 - 9(a + b)x + (2a^2 + 5ab + 2b^2) = 0$

Sol:

i. Given quadratic equation $4x^2 - 2(a^2 + b^2)x + a^2 b^2 = 0$

$$(4 \times a^2 b^2 = 4a^2 b^2)(4a^2 b^2 = -2a^2 \times -2b^2)$$

$$\therefore 4x^2 - 2(a^2 + b^2)x + a^2 b^2 = 0$$

$$\Rightarrow 4x^2 - 2a^2x - 2b^2x + a^2b^2 = 0$$

$$\Rightarrow 2x(2x - a^2) - b^2(2x - a^2) = 0$$

$$\Rightarrow (2x - a^2)(2x - b^2) = 0$$

$$\Rightarrow (2x - a^2) = 0 \text{ (or) } (2x - b^2) = 0$$

$$\Rightarrow x = \frac{a^2}{2} \text{ or } \frac{b^2}{2}$$

ii. Given quadratic equation $9x^2 - 9(a + b)x + (2a^2 + 5ab + 2b^2) = 0$

Co-efficient of $x^2 \times$ constant term

$$= 9 \times (2a^2 + 5ab + 2b^2)$$

$$= 9 \times (2a^2 + 4ab + ab + 2b^2)$$

$$= 9(2a(a + 2b) + b(a + 2b))$$

$$= 9(a + 2b)(2a + b)$$

$$-3((a + 2b), (2a + b))$$

$$\therefore 9x^2 - 9(a + b)x + (2a^2 + 5ab + 2b^2) = 0$$

$$\Rightarrow 9x^2 - 3(a + 2b + 2a + b)x + (2a^2 + 5ab + 2b^2) = 0$$

$$\Rightarrow 9x^2 - 3(a + 2b)x - 3(2a + b)x + (a + 2b)(2a + b) = 0$$

$$\Rightarrow 3x[3x - (a + 2b)] - 3(2a + b)[3x - (a + 2b)] = 0$$

$$\Rightarrow [3x - (a + 2b)][3x - (2a + b)] = 0$$

$$\Rightarrow x = \frac{a + 2b}{3} \text{ (or) } \frac{(2a + b)}{3}$$

Model Problem

Solve the following quadratic equations by factorization method.

$$(i) x^2 + \left(\frac{a}{a+b} + \frac{a+b}{a} \right) x + 1 = 0$$

$$(ii) \frac{1}{a+b+x} = \frac{1}{a} + \frac{1}{b} + \frac{1}{x}$$

$$(iii) \frac{x-1}{x-2} + \frac{x-3}{x-4} = 3\frac{1}{3} (x \neq 2, 4)$$

$$(iv) x^2 - 2(a^2 + b^2)x + (a^2 - b^2)^2 = 0$$

Sol: (i) $x = -\frac{a}{a+b} \text{ (or) } -\frac{(a+b)}{a}$

(ii) $x = -a \text{ (or) } x = -b$

(iii) $x = 5 \text{ (or) } \frac{5}{2}$

(iv) $x = (a^2 + b^2) \pm 2ab$

28) Solve the following equations by the method of completing the square?

(i) $4x^2 + 4bx - (a^2 - b^2) = 0$

(ii) $a^2x^2 - 3abx + 2b^2 = 0$

Sol:

(i) Given quadratic equation $4x^2 + 4bx - (a^2 - b^2) = 0$

Dividing on both sides by 4, we get

$$\Rightarrow x^2 + bx - \left(\frac{a^2 - b^2}{4} \right) = 0$$

$$\Rightarrow x^2 + bx = \left(\frac{a^2 - b^2}{4} \right)$$

$$\Rightarrow x^2 + 2(x)\left(\frac{b}{2}\right) = \left(\frac{a^2 - b^2}{4}\right)$$

Adding $\left(\frac{b}{2}\right)^2$ on both sides, we get

$$\Rightarrow x^2 + 2(x)\left(\frac{b}{2}\right) + \left(\frac{b}{2}\right)^2 = \left(\frac{a^2 - b^2}{4}\right) + \left(\frac{b}{2}\right)^2$$

$$\Rightarrow \left(x + \frac{b}{2}\right)^2 = \frac{a^2 - b^2 + b^2}{4} = \frac{a^2}{4} = \left(\frac{a}{2}\right)^2$$

$$\Rightarrow x + \frac{b}{2} = \sqrt{\left(\frac{a}{2}\right)^2}$$

$$\Rightarrow x + \frac{b}{2} = \pm \frac{a}{2}$$

$$\Rightarrow x = -\frac{b}{2} \pm \frac{a}{2}$$

$$\Rightarrow x = -\frac{b}{2} + \frac{a}{2} \text{ (or) } x = -\frac{b}{2} - \frac{a}{2}$$

$$\Rightarrow x = \frac{a-b}{2} \text{ (or) } x = -\frac{(a+b)}{2}$$

(ii) Given quadratic equation $a^2x^2 - 3abx + 2b^2 = 0$

Dividing both sides by a^2 , we get

$$\Rightarrow x^2 - \frac{3ab}{a^2}x + 2\frac{b^2}{a^2} = 0$$

$$\Rightarrow x^2 - 3\left(\frac{b}{a}\right)x + 2\frac{b^2}{a^2} = 0$$

$$\Rightarrow x^2 - 3\left(\frac{b}{a}\right)x = -2\frac{b^2}{a^2}$$

$$\Rightarrow x^2 - 2x\left(\frac{3b}{2a}\right) = -2\frac{b^2}{a^2} \dots$$

Adding $\left(\frac{3b}{2a}\right)^2$ on both sides

$$\Rightarrow x^2 - 2x\left(\frac{3b}{2a}\right) + \left(\frac{3b}{2a}\right)^2 = -2\frac{b^2}{a^2} + \left(\frac{3b}{2a}\right)^2$$

$$\Rightarrow \left(x - \frac{3b}{2a}\right)^2 = -2\frac{b^2}{a^2} + \frac{9b^2}{4a^2} = \frac{-8b^2 + 9b^2}{4a^2} = \frac{b^2}{4a^2} = \left(\frac{b}{2a}\right)^2$$

$$\Rightarrow x - \frac{3b}{2a} = \sqrt{\left(\frac{b}{2a}\right)^2} = \pm \frac{b}{2a}$$

$$\Rightarrow x = \pm \frac{b}{2a} + \frac{3b}{2a}$$

$$\Rightarrow x = \frac{\pm b + 3b}{2a}$$

$$\Rightarrow x = \frac{-b + 3b}{2a} \text{ (or) } x = \frac{+b + 3b}{2a}$$

$$\Rightarrow x = \frac{2b}{2a} \text{ (or) } x = \frac{4b}{2a}$$

$$\Rightarrow x = \frac{b}{a} \text{ (or) } x = \frac{2b}{a}$$

Model Problem:

Solve the following quadratic equations by the method of completing the square.

(i) $ax^2 + bx + c = 0$

(ii) $x^2 - 4ax + 4a^2 - b^2 = 0$

(iii) $x^2 - (\sqrt{3} + 1)x + \sqrt{3} = 0$

(iv) $\sqrt{2}x^2 - 3x - 2\sqrt{2} = 0$

Answers:

(i) $x = \frac{-b \pm \sqrt{b^2 - 4ac}}{2a}$

(ii) $x = 2a - b$ (or) $2a + b$

(iii) $x = \sqrt{3}, 1$

$$(iv) \quad -\frac{1}{\sqrt{2}}, 2\sqrt{2}$$

29) Solve the following problems, using quadratic formula.

$$(i) \quad 12abx^2 - (9a^2 - 8b^2)x - 6ab = 0$$

$$(ii) \quad a^2 b^2 x^2 - (4b^4 - 3a^4)x - 12a^2 b^2 = 0$$

Sol:

$$(i) \quad \text{Given quadratic equation} \quad 12abx^2 - (9a^2 - 8b^2)x - 6ab = 0$$

Compare with $Ax^2 + Bx + C = 0$, we get

$$A = 12ab ; B = -(9a^2 - 8b^2) ; C = -6ab$$

Using the quadratic formula, we get

$$x = \frac{-b \pm \sqrt{b^2 - 4ac}}{2a}$$

$$x = \frac{-[-(9a^2 - 8b^2)] \pm \sqrt{[-(9a^2 - 8b^2)]^2 - 4(12ab)(-6ab)}}{2(12ab)}$$

$$x = \frac{9a^2 - 8b^2 \pm \sqrt{81a^4 + 64b^4 - 144a^2b^2 + 288a^2b^2}}{24ab}$$

$$x = \frac{9a^2 - 8b^2 \pm \sqrt{81a^4 + 64b^4 + 144a^2b^2}}{24ab}$$

$$x = \frac{9a^2 - 8b^2 \pm \sqrt{(9a^2 + 8b^2)^2}}{24ab}$$

$$x = \frac{9a^2 - 8b^2 \pm 9a^2 + 8b^2}{24ab}$$

$$x = \frac{9a^2 - 8b^2 + 9a^2 + 8b^2}{24ab} \quad (or) \quad x = \frac{9a^2 - 8b^2 - 9a^2 - 8b^2}{24ab}$$

$$x = \frac{18a^2}{24ab} \quad (or) \quad x = \frac{-16b^2}{24ab}$$

$$x = \frac{3a}{4b} \quad (or) \quad x = \frac{-2b}{3a}$$

(ii) Given quadratic equation $a^2 b^2 x^2 - (4b^4 - 3a^4) x - 12a^2 b^2 = 0$

Compare with $Ax^2 + Bx + C = 0$, we get

$A = a^2 b^2$; $B = -(4b^4 - 3a^4)$; $C = -12$

Using the quadratic formula, we get

$$x = \frac{-b \pm \sqrt{b^2 - 4ac}}{2a}$$

$$x = \frac{-[-(4b^4 - 3a^4)] \pm \sqrt{(-(4b^4 - 3a^4))^2 - 4(a^2 b^2)(-12a^2 b^2)}}{2a^2 b^2}$$

$$x = \frac{4b^4 - 3a^4 \pm \sqrt{16b^8 + 9a^8 - 24b^4 a^4 + 48a^4 b^4}}{2a^2 b^2}$$

$$x = \frac{4b^4 - 3a^4 \pm \sqrt{16b^8 + 9a^8 + 24b^4 a^4}}{2a^2 b^2}$$

$$x = \frac{4b^4 - 3a^4 \pm \sqrt{(4b^4 + 3a^4)^2}}{2a^2 b^2}$$

$$x = \frac{4b^4 - 3a^4 \pm 4b^4 + 3a^4}{2a^2 b^2}$$

$$x = \frac{4b^4 - 3a^4 + 4b^4 + 3a^4}{2a^2 b^2} \text{ (or) } x = \frac{4b^4 - 3a^4 - 4b^4 - 3a^4}{2a^2 b^2}$$

$$x = \frac{8b^4}{2a^2 b^2} \text{ (or) } x = \frac{-6a^4}{2a^2 b^2}$$

$$x = \frac{4b^2}{a^2} \text{ (or) } x = \frac{-3a^2}{2b^2}$$

Model Problem:

Solve the following problem, using quadratic formula.

(i) $(a + b)^2 x^2 + 8(a^2 - b^2) + 16(a - b)^2 = 0$, $a + b \neq 0$, $a \neq b$

(ii) $3x^2 a^2 + 8abx + 4b^2 = 0$, $a \neq 0$

Answers:

$$(i) \quad -4\left(\frac{a-b}{a+b}\right), -4\left(\frac{a-b}{a+b}\right)$$

$$(ii) \quad -\frac{2b}{a}, -\frac{2b}{3a}$$

30) Find the values of k for which the following equation has equal roots.

$$(k - 12)x^2 + 2(k - 12)x + 2 = 0$$

Sol: Given quadratic equation $(k - 12)x^2 + 2(k - 12)x + 2 = 0$ ----(1)

Compare with $ax^2 + bx + c = 0$, we get

$$a = k - 12 ; b = 2(k - 12); c = 2$$

Given that the roots of equation (1) are equal

i.e. discriminant $D = 0$

$$\Rightarrow b^2 - 4ac = 0$$

$$\Rightarrow (2(k - 12))^2 - 4(k - 12)(2) = 0$$

$$\Rightarrow 4(k - 12)^2 - 8(k - 12) = 0$$

$$\Rightarrow 4[(k - 12)^2 - 2(k - 12)] = 0$$

$$\Rightarrow (k - 12)^2 - 2(k - 12) = 0$$

$$\Rightarrow (k - 12)[(k - 12) - 2] = 0$$

$$\Rightarrow (k - 14)(k - 12) = 0$$

$$\Rightarrow (k - 14) = 0 \text{ (or) } (k - 12) = 0$$

$$\Rightarrow k = 14 \text{ (or) } k = 12$$

31) Prove that the equation $x^2 (a^2 + b^2) + 2x (ac + bd) + (c^2 + d^2) = 0$ has no real roots, if $ad \neq bc$.

Sol: Given quadratic equation

$$x^2 (a^2 + b^2) + 2x (ac + bd) + (c^2 + d^2) = 0$$

Compare with $ax^2 + bx + c = 0$, we get

$$a = a^2 + b^2; \quad b = 2(ac + bd); \quad c = c^2 + d^2$$

$$\text{Discriminant (d)} = b^2 - 4ac$$

$$= [2(ac + bd)]^2 - 4(a^2 + b^2)(c^2 + d^2)$$

$$= 4(a^2 c^2 + a^2 d^2 + 2abcd) - 4(a^2 c^2 + a^2 d^2 + b^2 c^2 + b^2 d^2)$$

$$= 4[a^2 c^2 + a^2 d^2 + 2abcd - a^2 c^2 - a^2 d^2 - b^2 c^2 - b^2 d^2]$$

$$= 4[-a^2 d^2 - b^2 c^2 + 2abcd]$$

$$= -4[a^2 d^2 + b^2 c^2 - 2abcd]$$

$$= -4[(ad - bc)^2]$$

Given that $ad \neq bc$

$$\Rightarrow ad - bc \neq 0$$

$$\Rightarrow (ad - bc)^2 > 0$$

$$D = -4(ad - bc)^2 < 0$$

$$(\because (ad - bc)^2 < 0 \quad -(ad - bc)^2 > 0)$$

Since $D < 0$, the given equation has no real roots.

32) If the roots of the equation $x^2 + 2cx + ab = 0$ are real unequal, prove that the equation $x^2 - 2(a + b)x + a^2 + b^2 + 2c^2 = 0$ has no real roots.

Sol: Given quadratic equations,

$$x^2 + 2cx + ab = 0 \text{ ---- (i)}$$

$$x^2 - 2(a + b)x + a^2 + b^2 + 2c^2 = 0 \text{ ----(ii)}$$

Since the roots of equation (i) are real and unequal.

$$\therefore \text{Discriminant } d = b^2 - 4ac > 0$$

$$\Rightarrow (2c)^2 - 4(1)(ab) > 0$$

$$\Rightarrow 4(c^2 - ab) > 0$$

$$\Rightarrow c^2 - ab > 0 (\because 4 > 0)$$

From the equation (2)

$$\text{Discriminant } d = b^2 - 4ac$$

$$\Rightarrow (-2(a+b))^2 - 4(a)(a^2 + b^2 + 2c^2)$$

$$\Rightarrow 4[a^2 + b^2 + 2ab - a^2 - b^2 - 2c^2]$$

$$\Rightarrow 4[2ab - 2c^2]$$

$$\Rightarrow 8(ab - c^2)$$

$$\Rightarrow -8(c^2 - ab) < 0 (\because c^2 - ab > 0)$$

Since $d < 0$, roots of equation (2) are not real.

SHORT ANSWER QUESTIONS

1) Check whether the following are quadratic equations?

(i) $x^3 - 4x^2 - x + 1 = (x - 2)^3$

(ii) $(x - 2)(x + 1) = (x - 1)(x + 3)$

Sol:

(i) Given $x^3 - 4x^2 - x + 1 = (x - 2)^3$

$$\Rightarrow x^3 - 4x^2 - x + 1 = x^3 - 8 + 3x(2)^2 - 3x^2(2)$$

$$((a - b)^3 = a^3 - b^3 - 3a^2b + 3ab^2)$$

$$\Rightarrow x^3 - 4x^2 - x + 1 = x^3 - 8 + 12x - 6x^2$$

$$\Rightarrow 6x^2 - 4x^2 - x - 12x + 1 + 8 = 0$$

$$\Rightarrow 2x^2 - 13x + 9 = 0$$

It is in the form of $ax^2 + bx + c = 0$, $a \neq 0$.

Hence the given equation is a quadratic equation.

(ii) Given $(x - 2)(x + 1) = (x - 1)(x + 3)$

$$\Rightarrow x^2 + x - 2x - 2 = x^2 + 3x - x - 3$$

$$\Rightarrow -x - 2 - 2x + 3 = 0$$

$$\Rightarrow -3x + 1 = 0$$

$$\Rightarrow 3x - 1 = 0$$

It is not in the form of $ax^2 + bx + c = 0$, $a \neq 0$.

Hence the given equation is not a quadratic equation.

2) Report the following situation in the form of quadratic equation?

(i) **Rohan's mother is 26 years older than him. The product of their ages after 3 years will be 360 years, we need to find Rohan's Present age.**

(ii) **A train travels a distance of 480km at a uniform speed. If the speed had been 8km/h less, then it would have taken 3 hours more to cover the same distance. We need to find the speed of train?**

Sol:

- (i) Let Rohan's present age = x years.

Then, the present age of his mother = $(x + 26)$ years (Given)

3 years from now (After 3 years)

Age of Rohan = $(x + 3)$ years

Age of his mother = $x + 26 + 3 = x + 29$

Given that product of their ages will be 360

$$\text{i.e. } (x + 3)(x + 29) = 360$$

$$\Rightarrow x^2 + 29x + 3x + 87 = 360$$

$$\Rightarrow x^2 + 32x - 87 = 0$$

\therefore Rohan's present age satisfies the quadratic equation

$$x^2 + 32x - 87 = 0$$

- (ii) Let the uniform speed of the train = x km/hour

The distance travelled by the train = 480 km.

$$\text{Time taken by the train} = \frac{\text{distance}}{\text{speed}} = \frac{480}{x}$$

If the speed had been 8 km/h less, then the speed of the train = $(x - 8)$ km/h

$$\text{Time taken by the train when the speed increase} = \frac{480}{x - 8}$$

Difference between the two timings $s = 3$ hours

$$\text{i.e. } \frac{480}{x - 8} - \frac{480}{x} = 3$$

Uniform speed of train satisfies the quadratic equation.

$$\frac{480}{x - 8} - \frac{480}{x} = 3$$

3) Find two numbers whose sum is 27 and product is 182.

Sol: Let the numbers are $x, (27 - x)$

(\therefore Given sum is 27)

Given that product of that two numbers = 182

$$\Rightarrow x(27 - x) = 182$$

$$\Rightarrow 27x - x^2 = 182$$

$$\Rightarrow 27x - x^2 - 182 = 0$$

$$\Rightarrow x^2 - 27x + 182 = 0$$

$$\Rightarrow x^2 - 13x - 14x + 182 = 0$$

$$\Rightarrow x(x - 13) - 14(x - 13) = 0$$

$$\Rightarrow (x - 13)(x - 14) = 0$$

$$\Rightarrow (x - 13) = 0 \text{ (or) } (x - 14) = 0$$

$$\Rightarrow x = 13 \text{ (or) } x = 14$$

$$27 - x = 27 - 13 \text{ (or) } 27 - 14 = 14 \text{ (or) } 13$$

So the required two numbers are 13, 14.

4) Solve the quadratic equation $\frac{2}{5}x^2 - x - \frac{3}{5} = 0$ by factorization method?

Sol:

Given quadratic equation $\frac{2}{5}x^2 - x - \frac{3}{5} = 0$

$$\Rightarrow \frac{2x^2 - 5x - 3}{5} = 0$$

$$\Rightarrow 2x^2 - 5x - 3 = 0$$

$$\Rightarrow 2x^2 - 6x + x - 3 = 0$$

$$\Rightarrow 2x(x - 3) + 1(x - 3) = 0$$

$$\Rightarrow (x - 3)(2x + 1) = 0$$

$$\Rightarrow (x - 3) = 0 \text{ (or) } (2x + 1) = 0$$

$$\Rightarrow x = 3 \text{ (or) } x = -1/2$$

5) Solve $9x^2 - 6ax + (a^2 - b^2) = 0$ by factorization method?

Sol: Given $9x^2 - 6ax + (a^2 - b^2) = 0$

$$\Rightarrow 9x^2 - [3(a + b) + 3(a - b)]x + (a^2 - b^2) = 0$$

$$\Rightarrow 9x^2 - 3(a + b)x - 3(a - b)x + (a + b)(a - b) = 0$$

$$\Rightarrow 3x [3x - (a + b)] - (a - b) [3x - (a + b)] = 0$$

$$\Rightarrow [3x - (a + b)] [3x - (a - b)] = 0$$

$$\Rightarrow 3x - (a + b) = 0 \text{ (or) } 3x - (a - b) = 0$$

$$x = \frac{a+b}{3} \text{ (or) } x = \frac{a-b}{3}$$

6) The sum of a number and its reciprocal is $2\frac{1}{42}$. Find the number?

Sol: Let the number = x

Reciprocal of that number = $1/x$

$$\text{Given that, } x + \frac{1}{x} = 2\frac{1}{42}$$

$$\Rightarrow x + \frac{1}{x} = \frac{85}{42}$$

Multiplying both sides with "42x"

$$42x^2 + 42 = 85x$$

$$\Rightarrow 42x^2 + 42 - 85x = 0$$

$$\Rightarrow 42x^2 - 49x - 36x + 42 = 0$$

$$\Rightarrow 7x(6x - 7) - 6(6x - 7) = 0$$

$$\Rightarrow (6x - 7)(7x - 6) = 0$$

$$\Rightarrow (6x - 7) = 0 \text{ (or) } (7x - 6) = 0$$

$$\Rightarrow x = 7/6 \text{ (or) } x = 6/7$$

7) Find the roots of the quadratic equation $2x^2 - 7x + 3 = 0$, by using method of completing the square?

Sol: Given $2x^2 - 7x + 3 = 0$

Dividing both sides with "2"

$$\Rightarrow x^2 - \frac{7}{2}x + \frac{3}{2} = 0$$

$$\Rightarrow x^2 - \frac{7}{2}x = -\frac{3}{2}$$

$$\Rightarrow x^2 - 2.(x).\frac{7}{4} = -\frac{3}{2}$$

Adding both sides by $\left(\frac{7}{4}\right)^2$

$$\Rightarrow x^2 - 2.(x).\frac{7}{4} + \left(\frac{7}{4}\right)^2 = -\frac{3}{2} + \left(\frac{7}{4}\right)^2$$

$$\Rightarrow \left(x - \frac{7}{4}\right)^2 = -\frac{3}{2} + \frac{49}{16} = \frac{-24 + 49}{16} = \frac{25}{16} = \left(\frac{5}{4}\right)^2$$

$$\Rightarrow x - \frac{7}{4} = \sqrt{\left(\frac{5}{4}\right)^2} = \pm \frac{5}{4}$$

$$\Rightarrow x = \pm \frac{5}{4} + \frac{7}{4}$$

$$\Rightarrow x = \frac{5}{4} + \frac{7}{4} \text{ (or) } x = -\frac{5}{4} + \frac{7}{4} = \frac{12}{4} \text{ (or) } \frac{2}{4}$$

$$\Rightarrow x = 3 \text{ (or) } \frac{1}{2}$$

8) Find the roots of the equation $x + \frac{1}{x} = 3$ by using quadratic formula?

Sol: Given $x + \frac{1}{x} = 3$

Multiplying with 'x' on both sides

$$\Rightarrow x^2 + 1 = 3x$$

$$\Rightarrow x^2 - 3x + 1 = 0$$

Comparing with $ax^2 + bx + c = 0$, we get $a = 1$, $b = -3$ $c = 1$

$$\text{Discriminant (d)} = b^2 - 4ac = (-3)^2 - 4(1)(1) = 9 - 4 = 5 > 0$$

Since $d > 0$, we can find the real root of given equation.

$$\Rightarrow x = \frac{-b \pm \sqrt{b^2 - 4ac}}{2(1)}$$

$$\Rightarrow x = \frac{-(-3) \pm \sqrt{5}}{2(1)}$$

$$\Rightarrow \frac{3 \pm \sqrt{5}}{2}$$

$$\Rightarrow \frac{3 + \sqrt{5}}{2} \text{ (or)} \Rightarrow \frac{3 - \sqrt{5}}{2}$$

9) Find the values of k for the quadratic equation $kx(x - 2) + 6 = 0$. So that they have two real equal roots?

Sol: Given quadratic equation $kx(x - 2) + 6 = 0$

$$\Rightarrow kx^2 - 2kx + 6 = 0$$

Comparing with $ax^2 + bx + c = 0$, we get $a = k$, $b = -2k$, $c = 6$

Since the given quadratic has two equal real roots discriminant $(d) = 0$

$$\Rightarrow \text{i.e. } b^2 - 4ac = 0$$

$$\Rightarrow (-2k)^2 - 4(k)(6) = 0$$

$$\Rightarrow 4k^2 - 24k = 0$$

$$\Rightarrow 4k(k - 6) = 0$$

$$\Rightarrow k = 0 \text{ (or) } k - 6 = 0$$

$$\Rightarrow k = 0 \text{ (or) } k = 6$$

If $k = 0$ then the equation $0 \cdot x(x - 2) + 6 = 0 \Rightarrow 6 = 0$. This is not a quadratic equation. So $k \neq 0$.

$$\therefore k = 6$$

10) If -4 is a root of the quadratic equation $x^2 + px - 4 = 0$ and the quadratic equation $x^2 + px + k = 0$ has equal roots, find the value of k .

Sol: Given equations

$$x^2 + px - 4 = 0 \text{ ----(1)}$$

$$x^2 + px + k = 0 \text{ ----(2)}$$

-4 is a root of equation(1).

$$\text{i.e. } (-4)^2 + p(-4) - 4 = 0$$

$$\Rightarrow 16 - 4p - 4 = 0$$

$$\Rightarrow 12 - 4p = 0$$

$$\Rightarrow p = 3$$

Substitute $p = 3$ in equation (2) we get,

$$x^2 + 3x + k = 0 \text{ ----(3)}$$

Equation (3) has equal roots.

$$\text{Discriminant } b^2 - 4ac = 0$$

$$\Rightarrow (3)^2 - 4(1)(k) = 0$$

$$\Rightarrow 4k = 9$$

$$\Rightarrow k = 9/4$$

MULTIPLE CHOICE QUESTIONS

- 1) Which of the following is not a quadratic equation. [B]
 A) $(x - 2)^2 + 1 = 2x - 3$ B) $x(x + 1) + 8 = (x + 2)(x - 2)$
 C) $x(2x + 3) = x^2 + 1$ D) $(x + 2)^3 = x^3 - 4$
- 2) Which of the following is a quadratic equation? [A]
 A) $(x + 1)^2 = 2(x - 3)$ B) $(x - 2)(x + 1) = (x - 1)(x + 3)$
 C) $x^2 + 3x + 1 = (x - 2)^2$ D) $x^4 - 1 = 0$
- 3) The sum of a number and its reciprocal is $50/7$, then the number is [A]
 A) $1/7$ B) 5 C) $2/7$ D) $3/7$
- 4) The roots of the equation $3x^2 - 2\sqrt{6}x + 2 = 0$ are: [C]
 A) $\frac{2}{\sqrt{3}}, -\frac{2}{\sqrt{3}}$ B) $\frac{1}{\sqrt{3}}, -\frac{1}{\sqrt{3}}$ C) $\sqrt{\frac{2}{3}}, \sqrt{\frac{2}{3}}$ D) $\frac{1}{\sqrt{3}}, \frac{5}{\sqrt{3}}$
- 5) Which of the following equations has $1/5$ as a root? [A]
 A) $35x^2 - 2x - 1 = 0$ B) $2x^2 - 7x - 6 = 0$
 C) $10x^2 - 3x - 1 = 0$ D) $3x^2 - 2x - 1 = 0$
- 6) If $x^2 - 2x + 1 = 0$, then $x + 1/x = \dots$ then $k = \dots$ [B]
 A) 0 B) 2 C) 1 D) None
- 7) If 3 is a solution of $3x^2 + (k - 1)x + 9 = 0$, then $k = \dots$ [B]
 A) 11 B) -11 C) 13 D) -13
- 8) The roots of $x^2 - 2x - (r^2 - 1) = 0$ are [B]
 A) $1 - r, -r - 1$ B) $1 - r, r + 1$ C) $1, r$ D) $1 - r, r$
- 9) The sum of the roots of the equation $3x^2 - 7x + 11 = 0$ is [C]
 A) $11/3$ B) $-7/3$ C) $7/3$ D) $3/7$
- 10) The roots of the equation $\frac{x^2 - 8}{x^2 + 20} = \frac{1}{2}$ are [C]
 A) ± 3 B) ± 2 C) ± 6 D) ± 4

- 11) The roots of the quadratic equation $\frac{9}{x^2 - 27} = \frac{25}{x^2 - 11}$ are [C]
A) ± 3 B) ± 4 C) ± 6 D) ± 5
- 12) The roots of the equation $\sqrt{2x^2 + 9} = 9$ are [B]
A) $x = 6$ B) $x = \pm 6$ C) $x = -6$ D) 0
- 13) Which of the following equations has the product of its roots as 4? [A]
A) $x^2 + 4x + 4 = 0$ B) $x^2 + 4x - 4 = 0$
C) $-x^2 + 4x + 4 = 0$ D) $x^2 + 4x - 24 = 0$
- 14) The two roots of a quadratic equation are 2 and -1. The equation is [D]
A) $x^2 + 2x - 2 = 0$ B) $x^2 + x + 2 = 0$
C) $x^2 + x + 2 = 0$ D) $x^2 - x - 2 = 0$
- 15) If the sum of a quadratic equation are $3x^2 + (2k + 1)x - (k+5) = 0$, is equal to the product of the roots, then the value of k is..... [C]
A) 2 B) 3 C) 4 D) 5
- 16) The value of k for which 3 is a root of the equation $kx^2 - 7x + 3 = 0$ is [B]
A) -2 B) 2 C) 3 D) -3
- 17) If the difference of the roots of the quadratic equation $x^2 - ax + b$ is 1, then [C]
A) $a^2 - 4b = 0$ B) $a^2 - 4b = -1$
C) $a^2 - 4b = 1$ D) $a^2 - 4b = 4$
- 18) The quadratic equation whose one root $2 - \sqrt{3}$ is [A]
A) $x^2 - 4x + 1 = 0$ B) $x^2 + 4x - 1 = 0$
C) $x^2 - 4x - 1 = 0$ D) $x^2 - 2x - 3 = 0$
- 19) What is the condition that one root of the quadratic equation $ax^2 + bx + c$ is reciprocal of the other? [A]
A) $a = c$ B) $a = b$ C) $b = c$ D) $a + b + c = 0$

- 20) The roots of a quadratic equation $\frac{x}{p} = \frac{p}{x}$ are [**A**]
A) $\pm p$ B) $p, 2p$ C) $-p, 2p$ D) $-p, -2p$
- 21) If the roots of the equation $12x^2 + mx + 5 = 0$ are real and equal then **m** is equal to [**C**]
A) $8\sqrt{15}$ B) $2\sqrt{15}$ C) $4\sqrt{15}$ D) $10\sqrt{15}$
- 22) Which of the following equations has the equal roots? [**B**]
A) $x^2 + 6x + 5 = 0$ B) $x^2 - 8x + 16 = 0$
C) $6x^2 - x - 2 = 0$ D) $10x - \frac{1}{x} = 3$
- 23) If the equation $x^2 - 4x + 9$ has no real roots, then [**D**]
A) $a < 4$ B) $a \leq 4$ C) $a < 2$ D) $a > 4$
- 24) The discrimination of the quadratic equation $7\sqrt{3}x^2 + 10x - \sqrt{3} = 0$ is [**C**]
A) 142 B) $\frac{-10}{7\sqrt{3}}$ C) 184 D) 26
- 25) The value of $\sqrt{6 + \sqrt{6 + \sqrt{6 + \sqrt{6 + \dots}}}}$ is [**B**]
A) 4 B) 3 C) -2 D) 3.5

FILL IN THE BLANKS

- 1) Standard form of a quadratic equation is $(ax^2 + bx + c = 0, a \neq 0)$
- 2) The sum of a number and its reciprocal is $\frac{5}{2}$. This is represent as $(x + \frac{1}{x} = \frac{5}{2})$
- 3) “The sum of the squares of two consecutive natural numbers is 25”, is represent as $(x^2 + (x - 1)^2 = 25)$
- 4) If one root of a quadratic equation is $7 - \sqrt{3}$ then the other root is $(7 + \sqrt{3})$
- 5) The discriminant of $5x^2 - 3x - 2 = 0$ is (49)
- 6) The roots of the quadratic equation $x^2 - 5x + 6 = 0$ are $(2, 3)$
- 7) If $x = 1$ is a common root of the equations $ax^2 + ax + 3 = 0$ and $x^2 + x + b = 0$ then the value of ab is (3)
- 8) If the discriminant of the quadratic equation $ax^2 + bx + c = 0$ is zero, then the roots of the equation are (Real and equal)
- 9) The product of the roots of the quadratic equation $\sqrt{2}x^2 - 3x + 5\sqrt{2} = 0$ is (5)
- 10) The nature of the roots of a quadratic equation $4x^2 - 12x + 9 = 0$ is (real and equal)
- 11) If the equation $x^2 - bx + 1 = 0$ does not possess real roots, then
 $(b^2 - 4 < 0 \text{ (or) } b^2 < 4 \text{ (or) } -2 < b < 2)$
- 12) If the sum of the roots of the equation $x^2 - (k + 6)x + 2(2k - 1) = 0$ is equal to half of their product, then $k = \dots$ (7)
- 13) If one root of the equation $4x^2 - 2x + (\lambda - 4) = 0$ be the reciprocal of the other, then $\lambda = \dots$ (8)
- 14) If $\sin\alpha$ and $\cos\alpha$ are the roots of the equation $ax^2 + bx + c = 0$, then $b^2 = \dots$ $(a^2 + 2ac)$
- 15) If the roots of the equation $(a^2 + b^2)x^2 - 2b(a + c)x + (b^2 + c^2) = 0$ are equal, then $b^2 = \dots$ (ac)
- 16) The quadratic equation whose roots are $-3, -4$ is $(x^2 + 7x + 12 = 0)$
- 17) If $b^2 - 4ac < 0$ then the roots of quadratic equation $ax^2 + bx + c = 0$ are
 $(\text{Not real or imaginary})$

Chapter – 6

Progressions

- Evidence is found that Babylonians some 400 years ago, knew of arithmetic and geometric progressions.
- Among the Indian mathematicians, Aryabhata (470 AD) was the first to give formula for the sum of squares and cubes of natural numbers in his famous work “Aryabhata”
- Indian mathematician Brahmagupta (598 AD), Mahavira (850 AD) and Bhaskara (1114 – 1185 AD) also considered the sums of squares and cubes.

- **Arithmetic progression(A.P)**

An arithmetic progression (AP) is a list of numbers in which each term is obtained by term adding a fixed number ‘d’ to preceding term, except the first term. The fixed number ‘d’ is called the common difference

Ex: 1, 2, 7, 10, 13..... are in AP Here $d = 3$

- Let $a_1, a_2, a_3, \dots, a_k, a_{k+1}, \dots, a_n, \dots$ be an AP.

Let its common difference be d, then

$$d = a_2 - a_1 = a_3 - a_2 = \dots = a_{k+1} - a_k = \dots$$

- If the first term is ‘a’ and the common difference is ‘d’ then $a, a + d, a + 2d, a + 3d, \dots$ is an A.P.

- **General term of an A.P.**

Let ‘a’ be the first term and ‘d’ be the common difference of an A.P., Then, its nth term or general term is given by $a_n = a + (n - 1) d$

Ex: The 10th term of the A.P. given by 5, 1 – 3, – 7,.....

$$\text{is } a_{10} = 5 + (10 - 1) (-4) = -31$$

- If the number of terms of an A.P. is finite, then it is a finite A.P.

Ex: 13, 11, 9, 7, 5

- If the number of terms of an A.P. is infinite, then it is an infinite A.P.

Ex: 4, 7, 10, 13, 16, 19,

- Three numbers in AP should be taken as $a - d, a, a + d$.
- Four numbers in AP should be taken as $a - 3d, a - d, a + d, a + 3d$.
- Five numbers in AP should be taken as $a - 2d, a - d, a, a + d, a + 2d$
- Six numbers in AP should be taken as $a - 5d, a - 3d, a - d, a + d, a + 3d, a + 5d$.
- If a, b, c are in AP, then $b = \frac{a+c}{2}$ is called the arithmetic mean if 'a' and 'c'.
- The sum of the first 'n' terms of an AP is given by $s_n = \frac{n}{2}[2a + (n-1)d]$.
- If the first and last terms of an AP are 'a' and 'l', the common difference is not given then $s_n = \frac{n}{2}[a+l]$.
- $a_n = s_n - s_{n-1}$
- The sum of first 'n' positive integers $s_n = \frac{n(n+1)}{2}$.
- **Ex:** sum of first '10' positive integers $= \frac{10(10+1)}{2} = 55$.

Geometric progression (G.P.)

A Geometric Progression is a list of numbers in which each term is obtained by multiplying preceding term with a fixed number 'r' except first term. This fixed number is called common ratio 'r'.

Ex: 3, 9, 27, 81, are in G.P.

Here common ratio $r = 3$

- A list of numbers $a_1, a_2, a_3, \dots, a_n, \dots$ are in G. P. Then the common ratio

$$r = \frac{a_2}{a_1} = \frac{a_3}{a_2} = \dots = \frac{a_n}{a_{n-1}} = \dots$$

- The first term of a G.P. by 'a' and common ratio 'r' then the G.P is a, ar, ar^2, \dots
- If the first term and common ratio of a G.P. are a, r respectively then nth term $a_n = ar^{n-1}$.

1 Mark Questions

1. Do the irrational numbers $\sqrt{2}, \sqrt{8}, \sqrt{18}, \sqrt{32}, \dots$ form an A.P? If so find common difference?

Sol: Given irrational numbers are $\sqrt{2}, \sqrt{8}, \sqrt{18}, \sqrt{32}, \dots$

$$d = a_2 - a_1$$

$$\Rightarrow \sqrt{8} - \sqrt{2}$$

$$\Rightarrow \sqrt{4 \times 2} - \sqrt{2}$$

$$\Rightarrow 2\sqrt{2} - \sqrt{2}$$

$$\Rightarrow \sqrt{2}$$

$$\sqrt{18} - \sqrt{8} = \sqrt{9 \times 2} - \sqrt{4 \times 2}$$

$$\Rightarrow 3\sqrt{2} - 2\sqrt{2}$$

$$\Rightarrow \sqrt{2}$$

Here common difference is same. i.e $\sqrt{2}$

\therefore The numbers are in A.P.

2. Write first four terms of the A.P, when the first term 'a' and common difference 'd' are given as follow.

$$a = -1.25, d = -0.25$$

Sol: $a_1 = a = -1.25, d = -0.25$

$$a_2 = a + d = -1.25 - 0.25 = -1.50$$

$$a_3 = a + 2d = -1.25 + 2(-0.25) = -1.75$$

$$a_4 = a + 3d = -1.25 + 3(-0.25) = -2.00$$

$$\therefore AP = -1.25, -1.5, -1.75, -2.$$

3. Is the following forms AP? If it, form an AP, find the common difference d and write three more terms.

Sol: $\sqrt{2}, \sqrt{8}, \sqrt{18}, \sqrt{32}, \dots$

Here $a = \sqrt{2}$

$$d = a_2 - a_1 = \sqrt{8} - \sqrt{2} = \sqrt{2 \times 4} - \sqrt{2} = 2\sqrt{2} - \sqrt{2} = \sqrt{2}$$

$$d = a_3 - a_2 = \sqrt{18} - \sqrt{8} = \sqrt{9 \times 2} - \sqrt{2 \times 4} = 3\sqrt{2} - 2\sqrt{2} = \sqrt{2}$$

$$d = a_4 - a_3 = \sqrt{32} - \sqrt{18} = \sqrt{4 \times 4 \times 2} - \sqrt{9 \times 2} = 4\sqrt{2} - 3\sqrt{2} = \sqrt{2}$$

'd' is equal for all. So it forms an AP

Next three terms

$$a_5 = a_4 + d = \sqrt{32} + \sqrt{2} = \sqrt{16 \times 2} + \sqrt{2} = 4\sqrt{2} + \sqrt{2} = 5\sqrt{2} = \sqrt{25 \times 2} = \sqrt{50}$$

$$a_6 = a_5 + d = \sqrt{50} + \sqrt{2} = \sqrt{25 \times 2} + \sqrt{2} = 5\sqrt{2} + \sqrt{2} = 6\sqrt{2} = \sqrt{36 \times 2} = \sqrt{72}$$

$$a_7 = a_6 + d = \sqrt{72} + \sqrt{2} = \sqrt{36 \times 2} + \sqrt{2} = 6\sqrt{2} + \sqrt{2} = 7\sqrt{2} = \sqrt{49 \times 2} = \sqrt{98}$$

$$\therefore \sqrt{50}, \sqrt{72}, \sqrt{98}.$$

4. If an AP $a_n = 6n + 2$ find the common difference

Sol: Let $a_n = 6n + 2$

$$a_1 = 6(1) + 2 =$$

$$= 6 + 2$$

$$= 8$$

$$a_2 = 6(2) + 2 = 12 + 2 = 14$$

$$a_3 = 6(3) + 2 = 18 + 2 = 20$$

$$d = a_2 - a_1$$

$$= 14 - 8$$

$$= 6.$$

Common difference = 6.

5. In G.P. 2, -6, 18, -54 find a_n

Sol: $a = 2$

$$r = \frac{a_2}{a_1} = \frac{-6}{2} = -3$$

$$a_n = a.r^{n-1}$$

$$= 2.(-3)^{n-1}$$

6. The 17th term of an A.P exceeds its 10th term by 7. Find the common difference.

Sol: Given an A.P in which $a_{17} = a_{10} + 7$

$$\Rightarrow a_{17} - a_{10} = 7 \Rightarrow (a + 16d) - (a + 9d) = 7$$

$$\Rightarrow 7d = 7$$

$$\Rightarrow d = \frac{7}{7} = 1$$

7. A man helps three persons. He ask each or them to give their help another three persons. If the chain continued like this way. What are the numbers obtained this series

Sol: First person = 1

No.of person taken help from 1st person = 3

No.of person taken help from the persons taken help from first person = $3^2 = 9$

Similarly, no.of persons taken help 27, 81, 243, ... progression 1, 3, 9, 27, 81, 243

In the above progression $a_1 = 1, a_2 = 3, a_3 = 9$

$$\text{Common ratio (r)} = \frac{a_2}{a_1} = \frac{a_3}{a_2} = \frac{3}{1} = \frac{9}{3} = 3$$

So, above progression is in G.P.

8. Find the sum of 8 terms of a G.P., whose nth term is 3^n .

Sol: In a G.P. nth term $(a_n) = 3^n$

$$a_1 = 3^1 = 3$$

$$a_2 = 3^2 = 9$$

$$a_3 = 3^3 = 27 \dots\dots$$

\therefore Geometric progression = 3, 9, 27.....

First term (a) = 3

$$\text{Common ratio (r)} = \frac{a_2}{a_1} = \frac{9}{3} = 3 > 1$$

No. of terms (n) = 8

$$\text{Sum of terms } (s_n) = \frac{a(r^n - 1)}{r - 1}$$

$$\begin{aligned} \text{Sum of 8 terms } (s_8) &= \frac{3(3^8 - 1)}{3 - 1} \\ &= \frac{3}{2}(3^8 - 1) \end{aligned}$$

9. In A.P n^{th} term $a_n = a + (n - 1) d$ explain each term in it.

Sol: $a_n = a + (n - 1) d$

a = First term

n = No. of terms

d = Common difference

$a_n = n^{\text{th}}$ term.

10. 6, 18, 54 is it in G.P. What is the common ratio?

Sol: Given that 6, 18, 54.....

$$r = \frac{a_2}{a_1} = \frac{18}{6} = 3$$

$$r = \frac{a_3}{a_2} = \frac{54}{18} = 3$$

$$\frac{a_2}{a_1} = \frac{a_3}{a_2} = 3$$

So, 6, 18, 54, i.. is in G.P. Common ratio = 3.

11. Find sum of series 7, 13, 19..... upto 35 terms

Sol: Given that 7, 13, 19.....

$$a_1 = 7$$

$$d = a_2 - a_1 = 13 - 7 = 6$$

$$\text{No. of terms } (n) = 35$$

$$\text{Sum of terms } S_n = \frac{n}{2} [2a + (n-1)d]$$

$$S_{35} = \frac{35}{2} [2(7) + (35-1)6]$$

$$= \frac{35}{2} [14 + 34 \times 6]$$

$$= \frac{35}{2} [14 + 204]$$

$$= \frac{35}{2} \times 218$$

$$= 35 \times 109$$

$$= 3815.$$

12. What is 10th term in the series 3, 8, 13

Sol: Given series 3, 8, 13, it is in A.P.

$$\text{First term } (a) = 3$$

$$d = 8 - 3 = 5$$

$$n = 10$$

$$a_n = a + (n - 1)d$$

$$= 3 + (10 - 1) (5)$$

$$= 3 + 45$$

$$= 48$$

\therefore 10th term in given series $a_{10} = 48$.

13. can $x + 2$, $x + 4$ and $x + 9$ be in A.P. Justify your answer

Sol: **Given terms are:**

$$x + 2, x + 4, x + 9$$

$$a_2 - a_1 = (x + 4) - (x + 2)$$

$$= 2$$

$$a_3 - a_2 = (x + 9) - (x + 4)$$

$$= x + 9 - x - 4$$

$$= 5$$

$$a_2 - a_1 \neq a_3 - a_2.$$

\therefore Given terms are not in A.P.

14. In a G.P., first term is 9, 7th term is $\frac{1}{81}$ find the common ratio

Sol: G.P. first term $a_1 = 9 = 3^2$

$$7^{\text{th}} \text{ term } a_7 = \frac{1}{81} = \frac{1}{3^4}$$

$$a_7 = ar^6 = \frac{1}{81}$$

$$\frac{7^{\text{th}} \text{ term}}{1^{\text{st}} \text{ term}} = \frac{a_7}{a_1} = \frac{ar^6}{a} = \frac{\frac{1}{81}}{\frac{1}{9}} = \frac{1}{81} \times \frac{1}{9}$$

$$\Rightarrow r^6 = \frac{1}{3^4} \times \frac{1}{3^2}$$

$$r^6 = \left[\frac{1}{3} \right]^6$$

\therefore Common ratio $r = \frac{1}{3}$.

15. Write the general terms of an AP and GP.

Sol: The general terms of AP are $a, a + d, a + 2d, a + 3d, \dots$

The general terms of GP are a, ar, ar^2, ar^3, \dots

2 Mark Questions

1. Determine the A.P. whose 3rd term is 5 and the 7th term is 9.

Sol: we have

$$a_3 = a + (3 - 1) d = a + 2d = 5 \text{----- (1)}$$

$$a_7 = a + (7 - 1) d = a + 6d = 9 \text{----- (2)}$$

solving the pair of linear equations (1) and (2), we get

$$a + 2d = 5 \text{----- (1)}$$

$$a + 6d = 9 \text{----- (2)}$$

$$\begin{array}{r} - \quad - \quad - \\ \hline \end{array}$$

$$- 4d = -4$$

$$d = \frac{-4}{-4}$$

$$d = 1$$

substitute $d = 1$ in equ (1)

$$a + 2d = 5 \Rightarrow a + 2(1) = 5 \Rightarrow a = 5 - 2 = 3$$

$$\therefore a = 3 \text{ and } d = 1$$

Hence, the required AP is 3, 4, 5, 6, 7,.....

2. How many two-digit numbers are divisible by 3?

Sol: The list of two – digit numbers divisible by 3 are 12, 15, 1899. These terms are in A.P. $(\because t_2 - t_1 = t_3 - t_2 = 3)$

Here, $a = 12$, $d = 3$, $a_n = 99$

$$a_n = a + (n - 1)d$$

$$99 = 12 + (n - 1) 3$$

$$99 - 12 = (n - 1) \times 3$$

$$87 = (n - 1) 3$$

$$n - 1 = \frac{87}{3}$$

$$n - 1 = 29$$

$$n = 29 + 1 = 30$$

so, there are 30 two- digit numbers divisible by 3.

3. Find the respective term of $a_1 = 5$, $a_4 = 9\frac{1}{2}$ find a_2, a_3 in APs

Sol: Given $a_1 = a = 5$ ----- (1)

$$a_4 = a + 3d = 9\frac{1}{2} \text{ ----- (2)}$$

Solving the equ (1) and equ (2), we get

$$\text{equ (1) - equ (2)}$$

$$(a + 3d) - a = 9\frac{1}{2} - 5$$

$$a + 3d - a = 4\frac{1}{2}$$

$$3d = \frac{9}{2}$$

$$d = \frac{9 \times 1}{2 \times 3}$$

$$\therefore d = \frac{3}{2}$$

$$a_2 = a + d = 5 + \frac{3}{2} = \frac{10+3}{2} = \frac{13}{2}$$

$$a_3 = a_2 + d = \frac{13}{2} + \frac{3}{2} = \frac{16}{2} = 8$$

$$\therefore a_2 = \frac{13}{2}, a_3 = 8.$$

4. $a_2 = 38$; $a_6 = -22$ find a_1, a_3, a_4, a_5

Sol: Given $a_2 = a + d = 38$ ----- (1)

$$a_6 = a + 5d = -22$$
----- (2)

Equation (2) – equation (1)

$$(a + 5d) - (a + d) = -22 - 38$$

$$a + 5d - a - d = -22 - 38$$

$$4d = -60$$

$$d = \frac{-60}{4}$$

$$\therefore d = -15$$

$$a_2 = a + d = 38$$

$$a + (-15) = 38 \Rightarrow a - 15 = 38 \Rightarrow a = 38 + 15 \Rightarrow a = 53.$$

$$\therefore a_1 = a = 53$$

$$a_3 = a + 2d = 53 + 2(-15) = 53 - 30 = 23$$

$$a_4 = a + 3d$$

$$= 53 + 3(-15)$$

$$= 53 - 45$$

$$= 8$$

$$a_5 = a + 4d$$

$$= 53 + 4 (-15)$$

$$= 53 - 60$$

$$= -7$$

$$\therefore a_1 = 53, a_3 = 23, a_4 = 8, a_5 = -7.$$

5. Which term of the A.P: 3, 8, 13, 18..... is 78?

Sol: $a_n = 78$

$$a = 3$$

$$d = a_2 - a_1 = 8 - 3 = 5$$

$$a_n = a + (n - 1)d$$

$$78 = 3 + (n - 1) 5$$

$$78 = 3 + 5n - 5$$

$$78 = 5n - 2$$

$$5n = 78 + 2$$

$$5n = 80$$

$$n = \frac{80}{5}$$

$$n = 16$$

\therefore 16th term of the A.P is 78.

6. Find the 31st term of an AP whose 11th term is 38 and 16th term is 73.

Sol: Given $a_{11} = 38$, $a_{16} = 73$ and $a_{31} = ?$

$$\therefore a_n = a + (n - 1) d$$

$$a_{11} = a + 10 d = 38 \text{ ----- (1)}$$

$$a_{16} = a + 15d = 73 \text{ ----- (2)}$$

$$(2) - (1) \Rightarrow a + 15d = 73$$

$$a + 10d = 38$$

$$\begin{array}{r} - \quad - \quad - \\ \hline \end{array}$$

$$5d = 35$$

$$d = \frac{35}{5} = 7$$

Substitute $d = 7$ in equ (1)

$$a + 10d = 38$$

$$a + 10(7) = 38$$

$$a + 70 = 38$$

$$a = 38 - 70$$

$$a = -32$$

$$31^{\text{st}} \text{ term } a_{31} = a + 30d$$

$$= -32 + 30(7)$$

$$= -32 + 210$$

$$= 178$$

$\therefore 178$ is the 31^{st} term.

7. Find the sum of $7 + 10\frac{1}{2} + 14 + \dots + 84$

Sol: Given terms are in A.P.

$$\text{Here } a = 7, d = a_2 - a_1 = 10\frac{1}{2} - 7 = 3\frac{1}{2} = \frac{7}{2}, a_n = 84$$

$$a_n = a + (n - 1) d = 84$$

$$7 + (n - 1) \left(\frac{7}{2}\right) = 84$$

$$(n - 1) \left(\frac{7}{2}\right) = 84 - 7$$

$$(n - 1) \left(\frac{7}{2}\right) = 77$$

$$(n - 1) = 77 \times \frac{2}{7}$$

$$n - 1 = 22$$

$$n = 22 + 1 = 23$$

$$\therefore n = 23$$

$$s_n = \frac{n}{2} [a + l]$$

$$s_{23} = \frac{23}{2} [7 + 84]$$

$$= \frac{23}{2} [91]$$

$$= \frac{2093}{2}$$

$$\therefore S_{23} = 1046 \frac{1}{2}$$

8. In an AP given $a = 5$, $d = 3$, $a_n = 50$, find n and s_n

Sol: $a_n = a + (n - 1) d$

$$50 = 5 + (n - 1) 3 \quad (\because a = 5, d = 3, a_n = 50)$$

$$50 = 5 + 3n - 3$$

$$50 = 3n + 2$$

$$50 - 2 = 3n$$

$$3n = 48$$

$$n = \frac{48}{3}$$

$$\therefore n = 16$$

$$S_n = \frac{n}{2} [2a + (n-1)d]$$

$$S_{16} = \frac{16}{2} [2(5) + (16-1)(3)]$$

$$= 8 [10 + (15)(3)]$$

$$= 8 [10 + 45]$$

$$= 8 \times 55$$

$$\therefore S_{16} = 440.$$

9. In an AP given $a_3 = 15$, $S_{10} = 125$, find d and a_{10}

Sol: $a_3 = 15$, $S_{10} = 125$

$$a_3 = a + 2d = 15 \text{ ----- (1)}$$

$$S_n = \frac{n}{2} [2a + (n-1)d]$$

$$S_{10} = \frac{10}{2} [2a + (10-1)d] = 125$$

$$5[2a + 9d] = 125$$

$$2a + 9d = \frac{125}{5}$$

$$2a + 9d = 25 \text{ ----- (2)}$$

Equ (1) and equ (2)

$$a + 2d = 15 \text{ ----- (1) } \times 2$$

$$2a + 9d = 25 \text{ ----- (2) } \times 1$$

$$2a + 4d = 30$$

$$2a + 9d = 25$$

$$\begin{array}{r} - \quad - \quad - \\ \hline \end{array}$$

$$-5d = +5$$

$$d = \frac{+5}{-5}$$

$$\therefore d = -1$$

Substitute $d = -1$ in equ (1)

$$a + 2d = 15 \Rightarrow a + 2(-1) = 15 \Rightarrow a - 2 = 15$$

$$\Rightarrow a = 15 + 2 = 17$$

$$a_{10} = a + 9d = 17 + 9(-1) \Rightarrow 17 - 9 = 8$$

$$\therefore d = -1 \text{ and } a_{10} = 8$$

10. The first and the last terms of an AP are 17 and 350 respectively. If the common difference is 9, how many terms are there and what is their sum?

Sol: Given A.P in which $a = 17$

$$\text{Last term} = l = 350$$

$$\text{Common, difference, } d = 9$$

We know that, $a_n = a + (n - 1) d$

$$350 = 17 + (n - 1) (9)$$

$$350 = 17 + 9n - 9$$

$$350 = 9n + 8$$

$$9n = 350 - 8$$

$$9n = 342$$

$$n = \frac{342}{9}$$

$$\therefore n = 38$$

Now $S_n = \frac{n}{2}[a+l]$

$$S_{38} = \frac{38}{2}[17+350]$$

$$= 19 \times 367$$

$$= 6973$$

$$\therefore n = 38; S_n = 6973.$$

11. Which term of the G.P: 2, $2\sqrt{2}$, 4 is 128?

Sol: Here $a = 2$, $r = \frac{2\sqrt{2}}{2} = \sqrt{2}$

Let 128 be the n^{th} term of the GP

Then $a_n = ar^{n-1} = 128$

$$2(\sqrt{2})^{n-1} = 128$$

$$(\sqrt{2})^{n-1} = \frac{128}{2}$$

$$(\sqrt{2})^{n-1} = 64$$

$$2^{\frac{n-1}{2}} = 2^6 \qquad \left(\because \sqrt{2} = 2^{\frac{1}{2}} \right)$$

$$\frac{n-1}{2} = 6 \qquad \left(\because a^m = a^n \Rightarrow m = n \right)$$

$$n - 1 = 6 \times 2$$

$$n - 1 = 12$$

$$n = 12 + 1$$

$$\therefore n = 13$$

Hence 128 is the 13th term of the G.P.

12. Which term of the G.P. is 2, 8, 32, is 512?

Sol: Given G.P. is 2, 8, 32, is 512

$$a = 2, \quad r = \frac{a_2}{a_1} = \frac{8}{2} = 4$$

$$a_n = 512$$

$$a_n = ar^{n-1} = 512$$

$$\begin{array}{r} 2 \overline{)512} \\ \underline{2} \\ 2 \\ \underline{2} \\ 2 \\ \underline{2} \\ 2 \\ \underline{2} \\ 2 \\ \underline{2} \\ 2 \\ \underline{2} \\ 2 \\ \underline{2} \\ 0 \end{array}$$

$$2(4)^{n-1} = 512$$

$$2(2^2)^{n-1} = 2^9$$

$$2^{2n-1} = 2^9 \qquad \left(\because a^m \times a^n = a^{m+n} \right)$$

$$2n - 1 = 9 \quad (\because a^m = a^n \Rightarrow m = n)$$

$$2n = 9 + 1$$

$$n = \frac{10}{2} = 5$$

$$\therefore n = 5$$

512 is the 5th term of the given G.P.

13. $\sqrt{3}, 3, 3\sqrt{3}, \dots$ is 729?

Sol: Given G.P. is $\sqrt{3}, 3, 3\sqrt{3}, \dots$ is 729

$$a = \sqrt{3}$$

$$r = \frac{3}{\sqrt{3}} \times \frac{\sqrt{3}}{\sqrt{3}} = \frac{3\sqrt{3}}{3} = \sqrt{3}$$

$$\begin{array}{r} 3 \overline{)729} \\ \underline{3 \ 243} \\ 3 \ 81 \\ \underline{3 \ 27} \\ 3 \ 9 \\ \underline{3 \ 3} \\ 1 \end{array}$$

$$a_n = 729$$

$$a_n = a \cdot r^{n-1} = 729$$

$$\sqrt{3} \cdot (\sqrt{3})^{n-1} = 729$$

$$3^{\frac{1}{2}} \cdot 3^{\frac{n-1}{2}} = 3^6$$

$$3^{\frac{1+n-1}{2}} = 3^6$$

$$(\because a^m \times a^n = a^{m+n})$$

$$3^{\frac{1+n-1}{2}} = 3^6$$

$$3^{\frac{n}{2}} = 3^6 \quad (\because a^m = a^n \Rightarrow m = n)$$

$$\frac{n}{2} = 6$$

$$n = 6 \times 2$$

$$\therefore n = 12$$

$\therefore 729$ is the 12th term of the given G.P.

14. In a nursery, there are 17 rose plants in the first row, 14 in the second row, 11 in the third row and so on. If there are 2 rose plants in the last row, find how many rows of rose plants are there in the nursery.

Sol: Number of plants in first row = 17

Number of plants in second row = 14

Number of plants in third row = 11

\therefore The series formed as 17, 14, 11, 8, 5, 2; the terms are in A.P.

Here $a = 17$, $d = 14 - 17 = -3$

$$a_n = 2$$

$$a_n = a + (n - 1)d = 2$$

$$17 + (n - 1)(-3) = 2$$

$$17 - 3n + 3 = 2$$

$$20 - 3n = 2$$

$$3n = 20 - 2$$

$$3n = 18$$

$$n = \frac{18}{3}$$

$$\therefore n = 6$$

\therefore There are 6 rows in the nursery.

15. Which term of the sequence -1, 3, 7, 11 is 95?

Sol: Let the A.P. -1, 3, 7, 11..... 95

$$a = -1; d = 3 - (-1) = 3 + 1 = 4; a_n = 95$$

$$a + (n - 1) d = 95$$

$$-1 + (n - 1) (4) = 95$$

$$-1 + 4n - 4 = 95$$

$$4n - 4 = 95 + 1$$

$$4n - 4 = 96$$

$$4n = 96 + 4$$

$$4n = 100$$

$$n = \frac{100}{4} = 25$$

\therefore 25th term = 95.

16. A sum of Rs. 280 is to be used to award four prizes. If each prize after the first is Rs. 20 less than its preceding prize. Find the value of each of the prizes.

Sol: The value of prizes form an A.P

$$\therefore \text{ In A.P. } d = -20$$

$$S_n = 280$$

$$n = 4$$

$$\frac{n}{2}[2a+(n-1)d] = 280$$

$$\frac{4}{2}[2a+(4-1)(-20)] = 280$$

$$2[2a - 60] = 280$$

$$2a - 60 = \frac{280}{2}$$

$$2a - 60 = 140$$

$$2a = 140 + 60$$

$$2a = 200$$

$$a = \frac{200}{2}$$

$$\therefore a = 100$$

\therefore The value of each of the prizes = Rs 100, Rs 80, Rs 60, Rs 40.

17. If the 8th term of an A.P. is 31 and the 15th term is 16 more than the 11th term, find the A.P.

Sol: In an A.P. $a_8 = 31 \Rightarrow a_8 = a + 7d = 31$

$$a_{15} = 16 + a_{11} \Rightarrow a + 14d = 16 + a + 10d$$

$$14d - 10d = 16 + a - a$$

$$4d = 16$$

$$d = \frac{16}{4} = 4$$

$$a + 7d = 31 \text{ and } d = 4$$

$$a + 7(4) = 31$$

$$a + 28 = 31$$

$$a = 31 - 28$$

$$\therefore a = 3$$

\therefore A.P. is 3, 7, 11, 15, 19

18. Define Arithmetic progression and Geometric progression.

Sol: **Arithmetic Progression:** An arithmetic progression (AP) is a list of numbers in which each term is obtained by adding a fixed number 'd' to the preceding term, except the first term. The fixed number 'd' is called the common difference.

Geometric Progression: A geometric progression (G.P) is a list of numbers in which each term is obtained by multiplying preceding term with a fixed number 'r' except first term. This fixed number is called common ratio (r).

4 Mark Questions

1. If the 3rd & the 9th terms of an A.P. are 4 and -8 respectively. Which term of this AP is zero?

Sol: $a_3 = 4, a_9 = -8$

$$a_3 = a + 2d = 4 \text{ ----- (1)}$$

$$a_9 = a + 8d = -8 \text{ ----- (2)}$$

(2) – (1) we get

$$a + 8d = -8$$

$$a + 2d = 4$$

$$\begin{array}{r} - \quad - \quad - \\ \hline \end{array}$$

$$6d = -12$$

$$d = \frac{-12}{-6}$$

$$d = -2$$

Substitute $d = -2$ in the following equations

$$a_4 = a_3 + d = 4 + (-2) = 4 - 2 = 2$$

$$a_5 = a_4 + d = 2 + (-2) = 2 - 2 = 0$$

\therefore 5th term of the A.P becomes zero.

2. Find the 20th term from the end of A.P: 3, 8, 13 253

Sol: $a = 3, d = a_2 - a_1 = 8 - 3 = 5, a_n = 253$

$$a_n = a + (n - 1) d$$

$$253 = 3 + (n - 1) (5)$$

$$253 - 3 = (n - 1) 5$$

$$\frac{250}{5} = n - 1$$

$$n - 1 = 50$$

$$n = 51$$

∴ The 20th term from the other end would be $n - r + 1 = 51 - 20 + 1$
 $= 32.$

$$a_{32} = a + 31d$$

$$= 3 + 31(5)$$

$$= 3 + 155$$

$$= 158$$

The 20th term is 158.

3. The sum of the 4th and 8th terms of an A.P. is 24 and the sum of the 6th and 10th term is 44. Find the first three terms of the A.P.

Sol: $4^{\text{th}} + 8^{\text{th}} = 24$

$$\Rightarrow (a + 3d) + (a + 7d) = 24$$

$$\Rightarrow a + 3d + a + 7d = 24$$

$$\Rightarrow 2a + 10d = 24$$

$$\Rightarrow 2(a + 5d) = 24$$

$$\Rightarrow (a + 5d) = \frac{24}{2}$$

$$\therefore a + 5d = 12 \dots\dots\dots (1)$$

$$6^{\text{th}} + 10^{\text{th}} = 44$$

$$\Rightarrow (a + 5d) + (a + 9d) = 44$$

$$\Rightarrow a + 5d + a + 9d = 44$$

$$\Rightarrow 2a + 14d = 44$$

$$\Rightarrow 2(a + 7d) = 44$$

$$\Rightarrow a + 7d = \frac{44}{2}$$

$$\therefore a + 7d = 22 \text{----- (2)}$$

$$(2) - (1) = a + 7d = 22$$

$$a + 5d = 12$$

$$\begin{array}{r} - \quad - \quad - \\ \hline \end{array}$$

$$2d = 10$$

$$d = \frac{10}{2}$$

$$\therefore d = 5.$$

Substitute $d = 5$ in eq (1)

$$\text{We get, } a + 5(5) = 12$$

$$\Rightarrow a + 25 = 12$$

$$\Rightarrow a = 12 - 25$$

$$\Rightarrow a = -13$$

\therefore The first three terms of A.P are

$$a_1 = a = -13$$

$$a_2 = a + d = -13 + 5 = -8$$

$$a_3 = a + 2d = -13 + 2(5) = -13 + 10 = -3.$$

- 4. Subba rao started work in 1995 at an annual salary of Rs 5000 and received an increment of Rs 200 each year. In which year did his income reach Rs 7000?**

Sol:

Year	1995	1996	1997	1998	1999
Subba rao salary	5000	5200	5400	5600	5800

5000, 5200, 5400, 5600, 5800..... is in A.P.

$$a_n = a + (n - 1)d$$

$$= 5000 + (n - 1)(200) = 7000$$

$$= 5000 + 200n - 200 = 7000$$

$$= 200n + 4800 = 7000$$

$$= 200n = 7000 - 4800$$

$$= 200n = 2200$$

$$n = \frac{2200}{200}$$

$$\therefore n = 11.$$

\therefore The 11th is 7000.

\therefore In the year 2005 his income reaches to Rs 7000.

- 5. Given $a = 2$, $d = 8$, $S_n = 90$. Find n and a_n .**

Sol: $a_n = a + (n - 1)d$

$$= 2 + (n - 1)8$$

$$= 2 + 8n - 8$$

$$= 8n - 6$$

$$a = 2, d = 8, S_n = 90$$

$$S_n = \frac{n}{2} [2a + (n-1)d] = 90$$

$$\Rightarrow \frac{n}{2} [2(2) + (n-1)8] = 90$$

$$\Rightarrow \frac{n}{2} [4 + 8n - 8] = 90$$

$$\Rightarrow n [4 + 8n - 8] = 90 \times 2$$

$$\Rightarrow 4n + 8n^2 - 8n = 90 \times 2$$

$$\Rightarrow 4n + 8n^2 - 8n = 180$$

$$\Rightarrow 8n^2 + 4n - 8n = 180$$

$$\Rightarrow 8n^2 - 4n - 180 = 0$$

$$\Rightarrow 2n^2 - n - 45 = 0$$

$$\Rightarrow 2n^2 - 10n + 9n - 45 = 0$$

$$\Rightarrow 2n(n-5) + 9(n-5) = 0$$

$$\Rightarrow (n-5)(2n+9) = 0$$

$$n - 5 = 0 \quad 2n + 9 = 0$$

$$n = 5 \quad 2n = -9$$

$$n = \frac{-9}{2}$$

But we cannot take negative values so, $n = 5$

$$\therefore a_5 = a + 4d = 2 + 4(8)$$

$$= 2 + 32 = 34.$$

$$\therefore n = 5 \text{ and } a_5 = 34.$$

6. If the sum of first 7 terms of an A.P is 49 and that of 17 terms is 289, find the sum of first n terms.

Sol: The sum of first 7 terms of an A.P = 49.

$$S_n = \frac{n}{2}[2a + (n-1)d], \text{ where } S_n = 49$$

$$n = 7, \text{ then } \Rightarrow 49 = \frac{7}{2}[2a + (7-1)d]$$

$$\Rightarrow 49 \times \frac{2}{7} = 2a + 6d$$

$$\Rightarrow 14 = 2a + 6d$$

$$\Rightarrow 14 = 2(a + 3d)$$

$$\Rightarrow a + 3d = \frac{14}{2} = 7$$

$$\therefore a + 3d = 7 \text{ ----- (1)}$$

And the sum of 17 terms is 289,

$$S_n = \frac{n}{2}[2a + (n-1)d], S_n = 289, n = 17$$

$$\text{Then } 289 = \frac{17}{2}[2a + (17-1)d]$$

$$\Rightarrow 289 \times \frac{2}{17} = 2a + 16d$$

$$\Rightarrow 34 = 2a + 16d$$

$$\Rightarrow 34 = 2(a+8d) \Rightarrow a+8d = \frac{34}{2} = 17$$

$$a + 8d = 17 \text{ ----- (2)}$$

(1)(2) by solving

$$a + 8d = 17$$

$$a + 3d = 7$$

$$\begin{array}{r} - \quad - \quad - \\ \hline 5d = 10 \end{array}$$

$$d = \frac{10}{5}$$

$$\therefore d = 2$$

Substitute $d = 2$ in eq(1), we get

$$a + 3d = 7 \Rightarrow a + 3 \times 2 = 7 \Rightarrow a + 6 = 7$$

$$\Rightarrow a = 7 - 6$$

$$\therefore a = 1$$

The first 'n' terms sum $S_n = \frac{n}{2}[2a + (n-1)d]$

$a = 1, d = 2$, then on substituting, we get

$$S_n = \frac{n}{2}[2.1 + (n-1)2]$$

$$S_n = \frac{n}{2}[2 + 2n - 2]$$

$$= \frac{n}{2} \times 2n = n^2$$

$$S_n = n^2$$

\therefore The sum of first 'n' terms (S_n) = n^2 .

7. If the sum of the first n terms of an AP is $4n - n^2$, what is the first term (remember the first term is S_1)? What is the sum of first two terms? What is the second term? Similarly, find the 3rd, the 10th and the n th terms.

Sol: The sum of the first ' n ' terms of an A.P is $4n - n^2$

$$\text{First term } a_1 = S_1 = 4 \times 1 - 1^2 = 4 - 1 = 3 \quad (\because n = 1)$$

$$\text{First sum of the two terms} = 4 \times 2 - 2^2 = 8 - 4 = 4$$

$$S_3 = 4 \times 3 - 3^2 = 12 - 9 = 3 \quad a_2 = S_2 - S_1 = 4 - 3 = 1$$

$$\therefore \text{Third term } (a_3) = S_3 - S_2 = 3 - 4 = -1$$

$$S_{10} = 4 \times 10 - 10^2 = 40 - 100 = -60$$

$$S_9 = 4 \times 9 - 9^2 = 36 - 81 = -45$$

$$\text{Tenth term } (a_{10}) = S_{10} - S_9 = -60 - (-45) = -60 + 45 = 15$$

$$S_n = 4n - n^2$$

$$S_{n-1} = 4(n-1) - (n-1)^2$$

$$= 4n - 4 - (n^2 - 2n + 1)$$

$$= -n^2 + 6n - 5$$

$$\text{The } n\text{th term } a_n = S_n - S_{n-1}$$

$$\Rightarrow a_n = 4n - n^2 - (-n^2 + 6n - 5)$$

$$= 4n - n^2 + n^2 - 6n + 5$$

$$= 5 - 2n$$

$$\therefore S_1 = 3, S_2 = 4, a_2 = 1, a_3 = -1, a_{10} = -15, a_n = 5 - 2n.$$

8. A sum of Rs 700 is to be used to give seven cash prizes to students of a school for their overall academic performance. If each prize is Rs 20 less than its preceding prize, find the value of each of the prizes.

Sol: First term = Rs a

Each price is Rs 20 less than its preceding prize, then the remaining prize of gift (a - 20), (a - 40) ----- (a - 120), then

a, (a - 20), (a - 40) ----- (a - 120) forms an A.P

so, $S_n = \frac{n}{2}[a + a_n]$. Here $S_n = 700$, $n = 7$, $a = a$, $a_n = a - 120$, on substituting these

values we get

$$700 = \frac{7}{2}[a + a - 120]$$

$$700 \times \frac{2}{7} = 2a - 120$$

$$200 = 2a - 120$$

$$320 = 2a$$

$$a = \frac{320}{2}$$

$$\therefore a = 160$$

\therefore Each value of the prize Rs 160, Rs 140, Rs 120, Rs 100, Rs 80, Rs 60, Rs 40.

9. The number of bacteria in a certain culture triples every hour if there were 50 bacteria present in the culture originally. Then, what would be number of bacteria in fifth, tenth hour.

Sol: The no of bacteria in a culture triples every hour.

$$\therefore \text{No of bacteria in first hour} = 50$$

$$\text{No of bacteria in second hour} = 3 \times 50 = 150$$

$$\text{No of bacteria in third hour} = 3 \times 150 = 450$$

\therefore 50, 150, 450 would forms an G.P.

$$\text{First term (a)} = 50$$

$$\text{Common ratio (r)} = \frac{t_2}{t_1} = \frac{150}{50} = 3$$

$$\text{nth term } a_n = ar^{n-1}$$

$$\text{No of bacteria in 5}^{\text{th}} \text{ hour} = 50 \times 3^{5-1} = 50 \times 81 = 4050$$

$$\text{No of bacteria in 10}^{\text{th}} \text{ hour} = 50 \times 3^{10-1} = 50 \times 19683$$

$$= 984150$$

\therefore 3rd, 5th, 10th hours of bacteria number = 450, 4050, 984150.

10. The 4th term of a G.P is $\frac{2}{3}$ the seventh term is $\frac{16}{81}$. Find the Geometric series.

Sol: The 4th term of G.P = $\frac{2}{3}$, and the seventh term is $\frac{16}{81}$.

$$\text{i.e. } ar^3 = \frac{2}{3} \longrightarrow (1)$$

$$ar^6 = \frac{16}{81} \longrightarrow (2)$$

$\frac{(2)}{(1)}$, then we get

$$\frac{ar^6}{ar^3} = \frac{\frac{16}{81}}{\frac{2}{3}}$$

$$\Rightarrow r^3 = \frac{8}{27}$$

$$\Rightarrow r^3 = \left(\frac{2}{3}\right)^3$$

$$\therefore r = \frac{2}{3}$$

Now substitute $r = \frac{2}{3}$ in eq(1), we get

$$a \cdot \left(\frac{2}{3}\right)^3 = \frac{2}{3} \Rightarrow a \times \frac{8}{27} = \frac{2}{3}$$

$$\therefore a = \frac{9}{4}, r = \frac{2}{3}$$

Then A.P. a, ar, ar^2, ar^3, \dots

$$\frac{9}{4}, \frac{9}{4} \times \frac{2}{3}, \frac{9}{4} \times \frac{2^2}{3^2}, \frac{9}{4} \times \frac{2^3}{3^3}, \dots$$

$$\Rightarrow \frac{9}{4}, \frac{3}{2}, 1, \frac{2}{3}, \dots$$

11. If the geometric progressions 162, 54, 18 and $\frac{2}{81}, \frac{2}{27}, \frac{2}{9}, \dots$ have their nth term equal. Find its value of n?

Sol: 162, 54, 18

$$\text{Here } a = 162, r = \frac{a_2}{a_1} = \frac{54}{162} = \frac{1}{3}$$

The n^{th} term $= ar^{n-1} = 162 \left(\frac{1}{3}\right)^{n-1}$ (1)

$$\frac{2}{81}, \frac{2}{27}, \frac{2}{9}, \dots$$

Here $a = \frac{2}{81}, r = \frac{a_2}{a_1} = \frac{\frac{2}{27}}{\frac{2}{81}} = \frac{2}{27} \times \frac{81}{2} = 3$

$$n^{\text{th}} \text{ term} = a.r^{n-1} = \frac{2}{81} \cdot (3)^{n-1} \dots\dots\dots(2)$$

Given that n^{th} terms are equal

$$\Rightarrow 162 \times \left(\frac{1}{3}\right)^{n-1} = \frac{2}{81} \times (3)^{n-1} \quad (\because \text{From (1) \& (2)})$$

$$\Rightarrow 3^{n-1} \times 3^{n-1} = 162 \times \frac{81}{2}$$

$$\Rightarrow 3^{n-1+n-1} = 81 \times 81$$

$$\Rightarrow 3^{2n-2} = 3^4 \times 3^4$$

$$\Rightarrow 3^{2n-2} = 3^8 \quad [a^m \cdot a^n = a^{m+n}]$$

$$\Rightarrow 2n - 2 = 8$$

[if the bases are equal, exponents are also equal]

$$2n = 8 + 2$$

$$n = \frac{10}{2}$$

$$\therefore n = 5$$

\therefore The 5th terms of the two G.P. s are equal.

12. Find the 12th term of a G.P. whose 8th term is 192 and the common ratio is 2.

Sol: Given G.P $a_8 = 192$ & $r = 2$

$$a_n = a.r^{n-1}$$

$$a_8 = a (2)^{8-1} = 192$$

$$a.2^7 = 192 \Rightarrow a = \frac{192}{2^7} = \frac{192}{128} = \frac{12}{8} = \frac{3}{2}$$

$$\therefore a_{12} = a.r^{11} = \frac{3}{2} \times (2)^{11}$$

$$= 3 \times 2^{10} = 3 \times 1024$$

$$= 3072.$$

13. In an A.P 2nd, 3rd terms are 14 & 18 and find sum of first 51 terms?

Sol: **2nd term:**

3rd term:

$$a + d = 14 \dots\dots\dots (1)$$

$$a + 2d = 18 \dots\dots\dots (2)$$

$$a + d = 14$$

$$a + 2d = 18$$

- - -

$$-d = -4$$

$$d = 4$$

Substitute $d = 4$ in eq (1)

$$a + 4 = 14$$

$$a = 14 - 4$$

$$a = 10$$

$$S_n = \frac{n}{2} [2a + (n-1)d]$$

$$S_n = \frac{51}{2} [2(10) + (51-1)(4)]$$

$$\begin{aligned}
&= \frac{51}{2} [20 + (50)(4)] \\
&= \frac{51}{2} [20 + 200] \\
&= \frac{51}{2} [220] \\
&= 51 \times 110 \\
&= 5610
\end{aligned}$$

∴ The sum of first 51 term = 5610.

14. In an A.p, the sum of the ratio of the m and n terms in $m^2 : n^2$, then show that m^{th} term and n^{th} terms ratio is $(2m-1) : (2n-1)$.

Sol: AP, first term = a

Common difference = d

$$S_m = \frac{m}{2} [2a + (m-1)d]$$

$$S_n = \frac{n}{2} [2a + (n-1)d]$$

Given $\frac{S_m}{S_n} = \frac{m^2}{n^2}$

$$\frac{\frac{m}{2} [2a + (m-1)d]}{\frac{n}{2} [2a + (n-1)d]} = \frac{m^2}{n^2}$$

$$[2a + (m-1)d] n = [2a + (n-1)d] m$$

$$2a(n-m) = d[(n-1)m - (m-1)n]$$

$$2a(n-m) = d(n-m)$$

$$d = 2a$$

$$\frac{T_m}{T_n} = \frac{a + (m-1)2a}{a + (n-1)2a} = \frac{a + 2am - 2a}{a + 2an - 2a}$$

$$= \frac{2am - a}{2an - a} = \frac{a(2m-1)}{a(2n-1)}$$

$$\frac{T_m}{T_n} = \frac{2m-1}{2n-1}$$

15. The sum of n , $2n$, $3n$ terms of an A.P are S_1 , S_2 , S_3 respectively prove that $S_3 = 3(S_2 - S_1)$

Sol: In an A.P. first term is a and the common difference is d .

$$S_1 = \frac{n}{2}[2a + (n-1)d] \longrightarrow (1)$$

$$S_2 = \frac{2n}{2}[2a + (2n-1)d] \longrightarrow (2)$$

$$S_3 = \frac{3n}{2}[2a + (3n-1)d] \longrightarrow (3)$$

$$S_2 - S_1 = \frac{2n}{2}[2a + (2n-1)d] - \frac{n}{2}[2a + (n-1)d]$$

$$S_2 - S_1 = \frac{n}{2}[2a + (3n-1)d]$$

$$3(S_2 - S_1) = \frac{3n}{2}[2a + (3n-1)d] = S_3$$

$$S_3 = 3(S_2 - S_1)$$

Multiple Choice Questions

1. The n^{th} term of G.P is $a_n = ar^{n-1}$ where 'r' represents []
a) First term b) Common difference
c) Common ratio d) Radius
2. The n^{th} term of a G.P is $2(0.5)^{n-1}$ then r = []
a) 5 b) $\frac{1}{7}$ c) $\frac{1}{3}$ d) 0.5
3. In the A.P 10, 7, 4 -62, then 11th term from the last is []
a) -40 b) -23 c) -32 d) 10
4. Which term of the G.P $\frac{1}{3}, \frac{1}{9}, \frac{1}{27}, \dots$ is $\frac{1}{2187}$? []
a) 12 b) 8 c) 7 d) None
5. $n - 1, n - 2, n - 3, \dots, a_n = \dots$ []
a) n b) 0 c) -1 d) n^2
6. In an A.P a = -7, d = 5 then $a_{18} = \dots$ []
a) 71 b) 78 c) 87 d) 12
7. $2 + 3 + 4 + \dots + 100 = \dots$ []
a) 5050 b) 5049 c) 5115 d) 1155
8. $-1, \frac{1}{4}, \frac{3}{2}, \dots, s_{81} = \dots$ []
a) 3418 b) 8912 c) 3963 d) 3969
9. In G.P, 1st term is 2, Q common ratio is -3 then 7th term is []
a) 1458 b) -1458 c) 729 d) -729

10. **1, -2, 4, -8, is a Progression** []
a) A.P b) G.P c) Both d) None of these
11. **Common difference in $\frac{1}{2}, 1, \frac{3}{2}, \dots$** []
a) $\frac{-1}{2}$ b) $\frac{1}{2}$ c) 2 d) -2
12. **$\sqrt{3}, 3, 3\sqrt{3}, \dots$ is a** []
a) A.P b) G.P
c) Harmonic progression d) Infinite progression
13. **$a = \frac{1}{3}, d = \frac{4}{3}$, the 8th term of an A.P is _____** []
a) $\frac{7}{3}$ b) $\frac{29}{3}$ c) $\frac{29}{9}$ d) $\frac{29}{24}$
14. **Arithmetic progression in which the common difference is 3. If 2 is added to every term of the progression, then the common difference of new A.P.** []
a) 5 b) 6 c) 3 d) 2
15. **In an A.P. first term is 8 common difference is 2, then which term becomes zero** []
a) 6th term b) 7th term c) 4th term d) 5th term
16. **4, 8, 12, 16, is _____ series** []
a) Arithmetic b) Geometric
c) Middle d) Harmonic
17. **Next 3 terms in series 3, 1, -1, -3,** []
a) -5, -7, -9 b) 5, 7, 9 c) 4, 5, 6 d) -9, -11, -13

18. If x , $x + 2$ & $x + 6$ are the terms of G.P. then x _____ []
a) 2 b) -4 c) 3 d) 7
19. In G.P. $a_{p+q} = m$, $a_{p-q} = n$. Then $a_p =$ []
a) m^2n b) $\frac{m}{n}$ c) \sqrt{mn} d) $m\sqrt{n}$
20. $3 + 6 + 12 + 24 \dots\dots$ Progression, the n^{th} term is _____ []
a) $3 \cdot 2^{n-1}$ b) $-3 \cdot 2^{n-1}$ c) 2^{n+1} d) $2 \cdot 3^{n-1}$
21. $a_{12} = 37$, $d = 3$, then $S_{12} =$ _____ []
a) 264 b) 246 c) 4 d) 260
22. In the garden, there are 23 roses in the first row, in the 2nd row there are 19. At the last row there are 7 trees, how many rows of rose trees are there? []
a) 10 b) 9 c) 11 d) 7
23. From 10 to 250, how many multiples of 4 are _____ []
a) 40 b) 60 c) 45 d) 65
24. The taxi takes Rs. 30 for 1 hour. After for each hour Rs. 10, for how much money can be paid & how it forms progression []
a) Geometric progressions b) Harmonic progression
c) Series Progressions d) Arithmetic progression

Key

- 1) C 2) D 3) C 4) C 5) B 6) B 7) B 8) D
9) A 10) B 11) B 12) B 13) B 14) C 15) D 16) A
17) A 18) A 19) C 20) A 21) B 22) B 23) B 24) D

Bit Blanks

1. The sum of first 20 odd numbers _____
2. $10, 7, 4, \dots a_{30} =$ _____
3. $1 + 2 + 3 + 4 + \dots + 100 =$ _____
4. In the G.P $25, -5, 1, -\frac{1}{5}, \dots r =$ _____
5. The reciprocals of terms of G.P will form _____
6. If $-\frac{2}{7}, x, -\frac{7}{2}$ are in G.P. Then $x =$ _____
7. $1 + 2 + 3 + \dots + 10 =$ _____
8. If a, b, c are in G.P, then $\frac{b}{a} =$ _____
9. $x, \frac{4x}{3}, \frac{5x}{3}, \dots a_6 =$ _____
10. In a G.P $a_4 =$ _____
11. $\frac{1}{1000}, \frac{1}{100}, \frac{1}{10}, 1$ are in _____
12. The 10th term from the end of the A.P; $4, 9, 14, \dots 254$ is _____
13. In a G.P $a_{n-1} =$ _____
14. In an A.P $s_n - s_{n-1} =$ _____
15. $1.2 + 2.3 + 3.4 + \dots 5$ terms = _____
16. In a series $a_n = \frac{n(n+3)}{n+2}, a_{17} =$ -----
17. $-3, -\frac{1}{2}, 2, \dots$ A.P, the n^{th} term _____

18. $a_3 = 5$ & $a_7 = 9$, then find the A.P. _____
19. The n^{th} term of the G.P $2(0.5)^{n-1}$, then the common ratio _____
20. 4, -8, 16, -32 then find the common ratio is _____
21. The n^{th} term $t_n = \frac{n}{n+1}$ then $t_4 =$ _____
22. In an A.P $l = 28$, $s_n = 144$ & total terms are 9, then the first term is _____
23. In an A.P 11^{th} term is 38 and 16^{th} term is 73, then common difference of A.P is _____
24. In a garden there are 32 rose flowers in first row and 29 flowers in 2^{nd} row, and 26 flowers in 3^{rd} row, then how many rose trees are there in the 6^{th} row is _____
25. -5, -1, 3, 7 Progression, then 6^{th} term is _____
26. In Arithmetic progression, the sum of n^{th} terms is $4n - n^2$, then first term is _____

Key

- 1) 400; 2) -77; 3) 5050; 4) $\left(-\frac{1}{5}\right)$; 5) Geometric Progression;
- 6) ± 1 ; 7) 55; 8) $\frac{c}{b}$; 9) $\frac{8x}{3}$; 10) ar^3 ;
- 11) G.P.; 12) 209; 13) ar^{n-2} ; 14) a_n ; 15) 70;
- 16) $\frac{340}{19}$; 17) $\frac{1}{2}(5n-11)$; 18) 3, 4, 5, 6, 7; 19) 0.5; 20) -2;
- 21) $\frac{4}{5}$; 22) 4; 23) 7; 24) 17; 25) 15; 26) 3.

Chapter –8

Similar Triangles

Key Concepts:

1. A polygon in which all sides and angles are equal is called a regular polygon.
2. **Properties of similar Triangles:**
 - a) Corresponding sides are in the same ratio
 - b) Corresponding angles are equal
3. All regular polygons having the same number of sides are always similar
4. All squares and equilateral triangles are similar.
5. All congruent figures are similar but all similar figures need not be congruent.
6. **Thales Theorem (Basic proportionality Theorem):** If a line is drawn parallel to one side of a triangle to intersect the other two sides in distinct points, then the other two sides are divided in the same ratio.
7. If a line divides two sides of a triangle in the same ratio. Then the line is parallel to the third side.
8. **AAA criterion for similarity:** In two triangles, if the angles are equal, then the sides opposite to the equal angles are in the same ratio (or proportional) and hence the two triangles are similar.
9. **SSC criterion for similarity:** if in two triangles the sides of one triangle are proportional to the sides of the other triangle, then their corresponding angles are equal and hence the triangles are similar.

10. **SAS criterion for similarity:** if one angle of a triangle is equal to one angle of the other triangle and the sides including these angles are proportional, then the two triangles are similar.

11. If the areas of two similar triangles are equal, then they are congruent.

12. **Pythagoras theorem (Baudhayan Theorem):** In a right angle triangle, the square of hypotenuse is equal to the sum of the squares of the other two sides.

Short Questions

1. In $\triangle ABC$, $DE \parallel BC$ and $\frac{AD}{DB} = \frac{3}{5}$, $AC = 5.6$. Find AE .

Sol: In $\triangle ABC$, $DE \parallel BC$

$$\Rightarrow \frac{AD}{DB} = \frac{AE}{EC} \text{ (By Thales Theorem)}$$

$$\frac{AD}{DB} = \frac{3}{5} \text{ (Given), so } \frac{AE}{EC} = \frac{3}{5}$$

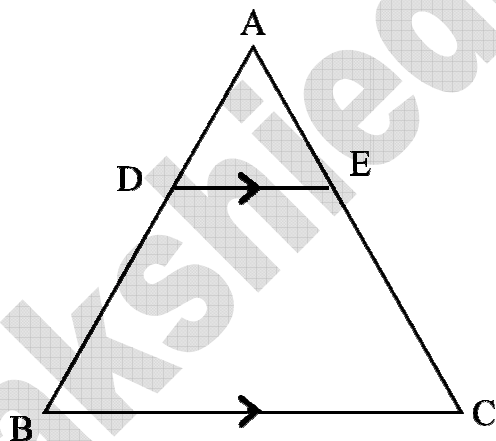

Given $AC = 5.6$; $AE : EC = 3:5$

$$\frac{AE}{AC - AE} = \frac{3}{5}$$

$$\frac{AE}{5.6 - AE} = \frac{3}{5}$$

$$5AE = 3(5.6 - AE) \text{ (cross multiplication)}$$

$$8AE = 16.8$$

$$\Rightarrow AE = \frac{16.8}{8} = 2.1 \text{ cm}$$

2. In a trapezium ABCD, AB//DC. E and F are points on non – parallel sides AD and BC respectively such that EF//AB show that $\frac{AE}{ED} = \frac{BF}{FC}$.

A. Let us join AC to intersect EF at G.

AB//DC and EF//AB (Given)

\Rightarrow EF//DC (Lines parallel to the same line are parallel to each other)

In ΔABC , EG//DC

$$\text{So, } \frac{AE}{ED} = \frac{AG}{GC} \text{ (By Thales Theorem)} \rightarrow (1)$$

Similarly In ΔCAB GF//AB

$$\frac{CG}{GA} = \frac{CF}{FB} \text{ (By Thales Theorem)}$$

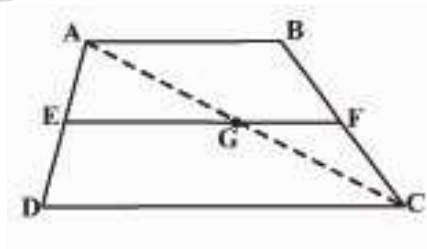

$$\frac{AG}{GC} = \frac{BF}{FC} \rightarrow (2)$$

From (1) and (2)

$$\frac{AE}{ED} = \frac{BF}{FC}$$

3. Prove that in two triangles, if the angles are equal, then the sides opposite to the equal angles are in the same ratio (or proportional) and hence the two triangles are similar.

Sol: Given: In triangles ABC and DEF

$$\angle A = \angle D, \angle B = \angle E \text{ and } \angle C = \angle F$$

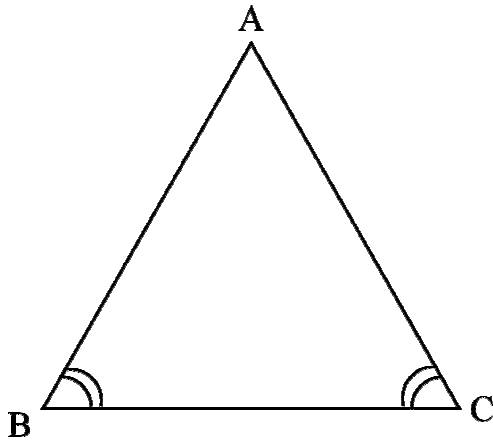

RTP: $\frac{AB}{DE} = \frac{BC}{EF} = \frac{AC}{DF}$

Construction: locate points P and Q on DE and DF respectively such that $AB = DP$ and $AC = DQ$. Join PQ.

Proof: $\triangle ABC \cong \triangle DPQ$

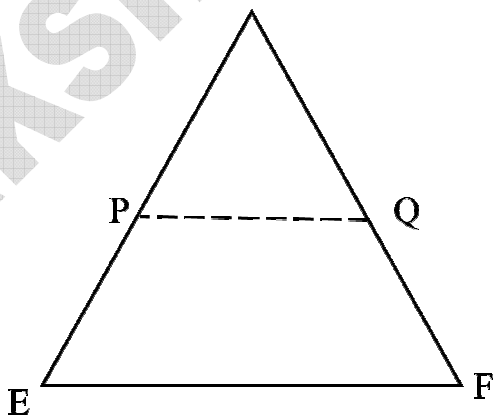

$$\angle B = \angle P = \angle E \text{ and } PQ \parallel EF$$

$$\frac{DP}{PE} = \frac{DQ}{QF}$$

$$i.e \frac{AB}{DE} = \frac{AC}{DF}$$

$$\text{Similarly } \frac{AB}{DE} = \frac{BC}{EF} \text{ and so } \frac{AB}{DE} = \frac{BC}{EF} = \frac{AC}{DF}$$

Hence proved

4. Prove that if the areas of two similar triangles are equal then they are congruent.

Sol: $\triangle ABC \sim \triangle PQR$

$$\text{So } \frac{\text{ar}(\triangle ABC)}{\text{ar}(\triangle PQR)} = \left(\frac{AB}{PQ}\right)^2 = \left(\frac{BC}{QR}\right)^2 = \left(\frac{AC}{PR}\right)^2$$

$$\text{But } \frac{\text{ar}(\triangle ABC)}{\text{ar}(\triangle PQR)} = 1 \text{ (areas are equal)}$$

$$\left(\frac{AB}{PQ}\right)^2 = \left(\frac{BC}{QR}\right)^2 = \left(\frac{AC}{PR}\right)^2 = 1$$

$$\text{So } AB^2 = PQ^2; BC^2 = QR^2; AC^2 = PR^2$$

From which we get $AB = PQ, BC = QR, AC = PR$

$\therefore \triangle ABC \cong \triangle PQR$ (by SSS congruency)

5. In a right angle triangle the square of hypotenuse is equal to the sum of the squares of the other two sides (Pythagoras theorem, (BAUDHAYAN THEOREM)).

Sol: Given: $\triangle ABC$ is a right angle triangle

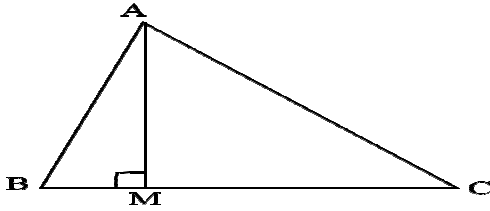

RTP: $AC^2 = AB^2 + BC^2$

Construction: Draw $AD \perp BC$

Proof: $\triangle ADB \sim \triangle ABC$

$$\frac{AD}{AB} = \frac{AB}{AC} \text{ (sides are proportional)}$$

$$AD \cdot AC = AB^2 \rightarrow (1)$$

Also $\triangle BDC \sim \triangle ABC$

$$\Rightarrow \frac{CD}{BC} = \frac{BC}{AC}$$

$$CD \cdot AC = BC^2 \rightarrow (2)$$

$$(1) + (2)$$

$$AD \cdot AC + CD \cdot AC = AB^2 + BC^2$$

$$AC (AD + CD) = AB^2 + BC^2$$

$$AC \cdot AC = AB^2 + BC^2$$

$$AC^2 = AB^2 + BC^2$$

6.The ratio of the areas of two similar triangles is equal to the ratio of the squares of their corresponding sides.

Sol: Given: $\triangle ABC \sim \triangle PQR$

RPT: $\frac{ar(\triangle ABC)}{ar(\triangle PQR)} = \left(\frac{AB}{PQ}\right)^2 = \left(\frac{BC}{QR}\right)^2 = \left(\frac{AC}{RP}\right)^2$

Construction: Draw $AM \perp BC$ and $PN \perp QR$

Proof: $\frac{ar(\triangle ABC)}{ar(\triangle PQR)} = \frac{\frac{1}{2} \times BC \times AM}{\frac{1}{2} \times QR \times PN} = \frac{BC \times AM}{QR \times PN} \rightarrow (1)$

In $\triangle ABM$ & $\triangle PQN$

$\angle B = \angle Q$ ($\because \triangle ABC \sim \triangle PQR$)

$\angle M = \angle N = 90^\circ$

$\therefore \triangle ABM \sim \triangle PQN$ (by AA similarity)

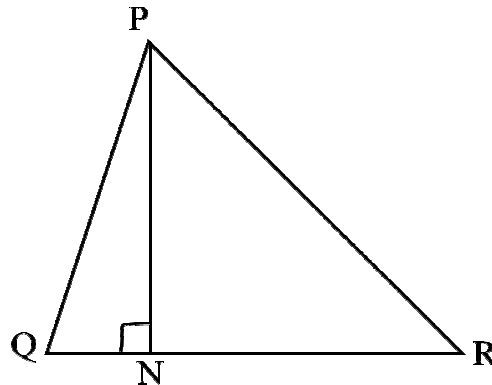
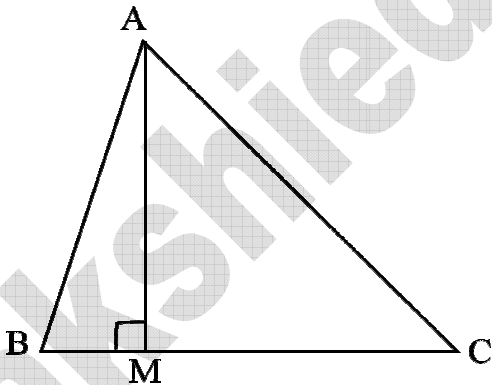

$\frac{AM}{PN} = \frac{AB}{PQ} \rightarrow (2)$

also $\triangle ABC \sim \triangle PQR$ (Given)

$\frac{AB}{PQ} = \frac{BC}{QR} = \frac{AC}{PR} \rightarrow (3)$

$$\frac{ar(\Delta ABC)}{ar(\Delta PQR)} = \frac{AB}{PQ} \times \frac{AB}{PQ} [now(1), (2) \& (3)]$$

$$= \left(\frac{AB}{PQ}\right)^2$$

Now by using (3), we get

$$\frac{ar(\Delta ABC)}{ar(\Delta PQR)} = \left(\frac{AB}{PQ}\right)^2 = \left(\frac{BC}{QR}\right)^2 = \left(\frac{AC}{PR}\right)^2 \text{ Hence proved}$$

7. Prove that the sum of the squares of the sides of a Rhombus is equal to the sum & squares of its diagonals.

Sol: in rhombus ABCD

$$AB = BC = CD = DA \text{ and}$$

Diagonals of rhombus perpendicularly bisect each other at 'o'

$$\text{So, } OA = OC \Rightarrow OA = \frac{AC}{2}$$

$$OB = OD \Rightarrow OD = \frac{BD}{2}$$

In ΔAOD , $\angle AOD = 90^\circ$

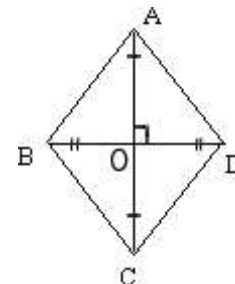

$$AD^2 = OA^2 + OD^2 \text{ (Pythagoras Theorem)}$$

$$= \left(\frac{AC}{2}\right)^2 + \left(\frac{BD}{2}\right)^2$$

$$= \frac{AC^2}{4} + \frac{BD^2}{4}$$

$$AD^2 = \frac{AC^2 + BD^2}{4}$$

$$4AD^2 = AC^2 + BD^2$$

$$AD^2 + AD^2 + AD^2 + AD^2 = AC^2 + BD^2$$

But $AB = BC = CD = AD$ (Given)

$$\therefore AB^2 + BC^2 + CD^2 + DA^2 = AC^2 + BD^2$$

8. Prove that a line drawn through the mid-point of one side of a triangle parallel to another side bisects the third side (using basic proportionality theorem)

Sol: Given: In $\triangle ABC$, D is the mid-point of AB and $DE \parallel BC$

To prove: $AE = CE$

Proof: by Thales theorem

$$\frac{AD}{DB} = \frac{AE}{EC} \rightarrow (1)$$

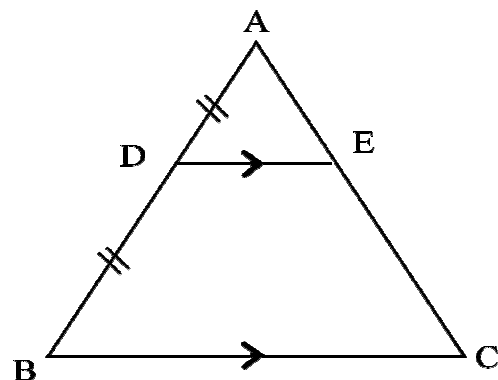

But D is the mid – point of AB

$$\Rightarrow AD = DB$$

$$\frac{AD}{DB} = 1$$

From (1) we get

$$\frac{AE}{EC} = 1$$

$$AE = CE$$

∴ AC is bisected by the parallel line

9. Prove that the ratio of areas of two similar triangles is equal to the square of the ratio of their corresponding medians.

Sol: Given: $\triangle ABC \sim \triangle DEF$ and AM and DN are their corresponding medians.

To prove: $\frac{ar(\triangle ABC)}{ar(\triangle DEF)} = \frac{AM^2}{DN^2}$

Proof: It is given that $\triangle ABC \sim \triangle DEF$

By the theorem on areas of similar triangles

$$\frac{ar(\triangle ABC)}{ar(\triangle DEF)} = \frac{AB^2}{DE^2}$$

$$\frac{AB^2}{DE^2} = \frac{BC^2}{EF^2} = \frac{AC^2}{DF^2} \rightarrow (1)$$

Also $\frac{AB}{DE} = \frac{BC}{EF} = \frac{2BM}{2EN} = \frac{BM}{EN}$

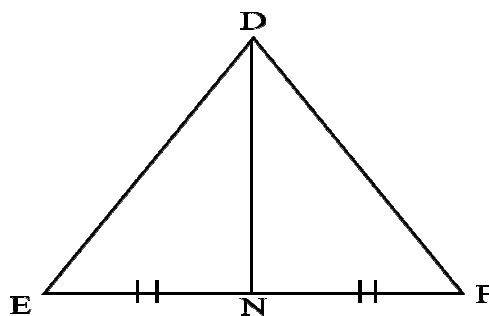
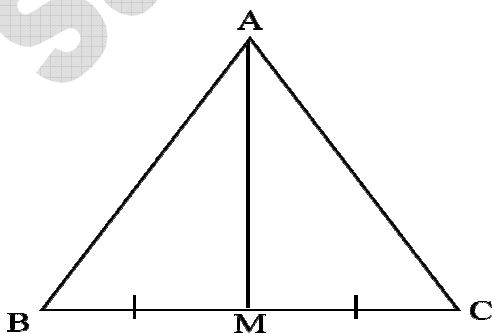

$$\Rightarrow \frac{AB}{DE} = \frac{BM}{EN}$$

Clearly $\angle ABM = \angle DEN$

SAS similarity criterion,

$$\Delta ABC \sim \Delta DEF$$

$$\frac{AB}{DE} = \frac{AM}{DN} \longrightarrow (2)$$

From (1) and (2) we get

$$\frac{ar(\Delta ABC)}{ar(\Delta DEF)} = \frac{AM^2}{DN^2}$$

Hence proved

10. A person 1.65m tall casts 1.8m shadow. At the same instance, a lamp-post casts a shadow of 5.4m. Find the height of the lamppost?

Sol: In ΔABC and ΔPQR

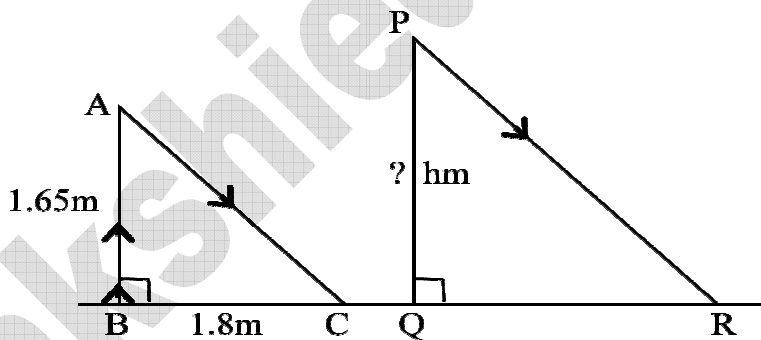

$$\angle B = \angle Q = 90^\circ$$

$$\angle C = \angle R \quad AC \parallel PR, \text{ (all sun's rays are parallel at any instance)}$$

$$\Delta ABC \sim \Delta PQR \text{ (by AA similarity)}$$

$$\frac{AB}{PQ} = \frac{BC}{QR} \text{ (corresponding parts of similar triangles)}$$

$$\frac{1.65}{PQ} = \frac{1.8}{5.4}$$

$$PQ = \frac{1.65 \times 54}{1.8} = 4.95m$$

Height of the lamp post = 4.95m.

11. The perimeters of two similar triangles are 30cm and 20cm respectively. If one side of the first triangle is 12cm, determine the corresponding side of the second triangle

Sol: Let the corresponding side of the second triangle be x m

We know that,

The ratio of perimeters of similar triangles = ratio of corresponding sides

$$\Rightarrow \frac{30}{20} = \frac{12}{x} \Rightarrow x = 8cm$$

∴ Corresponding side of the second triangle = 8cm

12. $\Delta ABC \sim \Delta DEF$ and their areas are respectively $64cm^2$ and $121cm^2$ If $EF = 15.4$ cm, Then Find BC .

Sol:
$$\frac{ar(\Delta ABC)}{ar(\Delta DEF)} = \left(\frac{BC}{EF}\right)^2$$

$$\frac{64}{121} = \left(\frac{BC}{15.4}\right)^2$$

$$\frac{8}{11} = \frac{BC}{15.4} \Rightarrow BC = \frac{15.4 \times 8}{11} = 11.2cm$$

13. $\Delta ABC \sim \Delta DEF$, $BC = 3\text{cm}$, $EF = 4\text{cm}$ and area of $\Delta ABC = 54\text{cm}^2$ Determine the area of ΔDEF .

Sol: $\Delta ABC \sim \Delta DEF$ $BC = 3\text{cm}$, $EF = 4\text{cm}$

$$\text{Area of } \Delta ABC = 54\text{cm}^2$$

By the theorem on areas of similar triangles,

$$\frac{\text{ar}(\Delta ABC)}{\text{ar}(\Delta DEF)} = \frac{BC^2}{EF^2}$$

$$\frac{54\text{cm}^2}{\text{ar}(\Delta DEF)} = \frac{9\text{cm}^2}{16\text{cm}^2}$$

$$\therefore \text{Area of } \Delta DEF = 96\text{ cm}^2$$

14. The areas of two similar triangles are 81cm^2 and 49 cm^2 respectively. If the altitude of the bigger triangle is 4.5cm . Find the corresponding altitude of the similar triangle.

Sol: We know that the ratio of areas of two similar triangles is equal to square of the ratio of their corresponding altitudes

$$\Rightarrow \frac{\text{area of bigger triangle}}{\text{area of smaller triangle}} = \left(\frac{\text{altitude of bigger triangle}}{\text{altitude of smaller triangle}} \right)^2$$

$$\Rightarrow \frac{81}{49} = \left(\frac{4.5}{x} \right)^2 \Rightarrow x = 3.5\text{cm}$$

Corresponding altitude of the smaller triangle = 3.5cm .

15. A ladder 25m long reaches a window of building 20m above the ground. Determine the distance of the foot of the ladder from the building.

Sol: In $\triangle ABC$, $\angle C = 90^\circ$

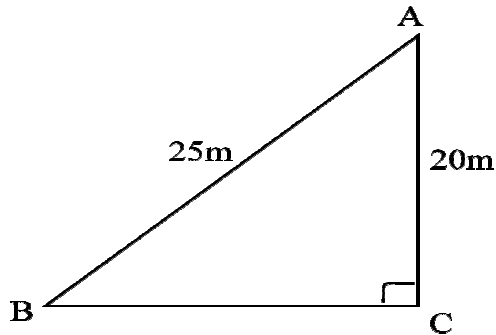

$$AB^2 = AC^2 + BC^2 \quad (\text{By Pythagoras Theorem})$$

$$25^2 = 20^2 + BC^2$$

$$BC^2 = 625 - 400 = 225\text{m}$$

$$BC = \sqrt{225} = 15\text{m}$$

\therefore The distance of the foot of the ladder from the building is 15m.

16. The hypotenuse of a right triangle is 6m more than twice of the shortest side if the third side is 2m less than the hypotenuse. Find the sides of the triangle.

Sol: Let the shortest side be x m

Then hypotenuse = $(2x + 6)$ m, third side = $(2x + 4)$ m

By Pythagoras Theorem we have

$$(2x + 6)^2 = x^2 + (2x + 4)^2$$

$$4x^2 + 36 + 24x = x^2 + 4x^2 + 16 + 16x$$

$$x^2 - 8x - 20 = 0$$

$$(x - 10)(x + 2) \Rightarrow x = +10, x = -2$$

But x can't be negative as side of a triangle

$$x = 10m$$

Hence the sides of the triangle are 10m, 26m, 24m.

17. Prove that three times the square of any side of an equilateral triangle is equal to four times the square of altitude

Sol: In $\triangle ABC$, $AB = BC = CA$, $AD \perp BC$

To prove: $3AB^2 = 4AD^2$

Proof: we have $AB = AC$ (Given)

$AD = AD$ (common side)

$\angle ADB = \angle ADC$ (Given)

$\triangle ADB \cong \triangle ADC$ (RHS congruently property)

$$\Rightarrow BD = CD = \frac{1}{2}BC = \frac{1}{2}AB$$

$\triangle ADB$ is right triangle

By Baudhayana Theorem

$$\begin{aligned} AB^2 &= AD^2 + BD^2 \\ &= AD^2 + \left(\frac{1}{2}AB\right)^2 = AD^2 + \frac{1}{4}AB^2 \end{aligned}$$

$$AD^2 = AB^2 - \frac{1}{4}AB^2$$

$$AD^2 = \frac{1}{4}AB^2$$

$$3 AB^2 = 4AD^2 \quad \text{Hence proved}$$

Essay Type Questions

1. Prove that if a line is drawn parallel to one side of a triangle to intersect the other two sides in distinct points then the other two sides are divided in the same Ratio (proportionality theorem / Thales Theorem).

Sol: Given: In $\triangle ABC$, $DE \parallel BC$ which intersects sides AB and AC at D and E respectively

RTP: $\frac{AD}{DB} = \frac{AE}{EC}$

Construction: Join B, E and C, D and then draw

$DM \perp AC$ and $EN \perp AB$

Proof: Area of $\triangle ADE = \frac{1}{2} \times AD \times EN$

Area of $\triangle BDE = \frac{1}{2} \times BD \times EN$

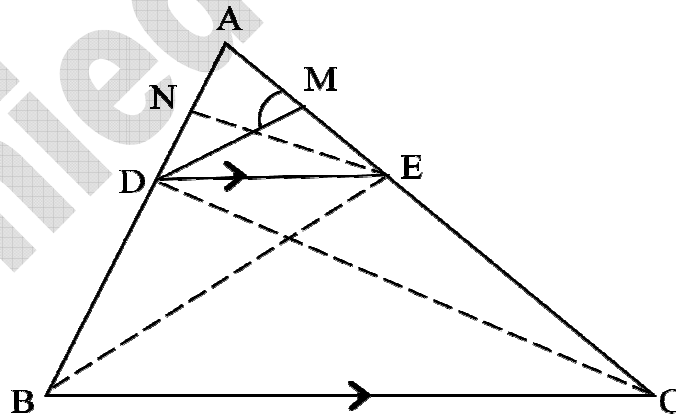

SO $\frac{\text{Area of } \triangle ADE}{\text{Area of } \triangle BDE} = \frac{\frac{1}{2} \times AD \times EN}{\frac{1}{2} \times BD \times EN} = \frac{AD}{BD} \rightarrow (1)$

Again Area of $\triangle ADE = \frac{1}{2} \times AE \times DM$

$$\text{Area of } \triangle CDE = \frac{1}{2} \times EC \times DM$$

$$\frac{\text{ar}(\triangle ABE)}{\text{ar}(\triangle CDE)} = \frac{\frac{1}{2} \times AE \times DM}{\frac{1}{2} \times EC \times DM} = \frac{AE}{CE} \rightarrow (2)$$

Observe that $\triangle BDE$ and $\triangle CDE$ are on the same base DE and between same parallels BC and DE

$$\text{So ar}(\triangle BDE) = \text{ar}(\triangle CDE) \rightarrow (3)$$

From (1) (2) & (3) we have

$$\frac{AD}{DB} = \frac{AE}{CE}$$

Hence proved

2. In the given figure $LM \parallel AB$ $AL = x - 3$, $AC = 2x$, $BM = x - 2$ and $BC = 2x + 3$ find the value of x .

Sol: in $\triangle ABC$, $LM \parallel AB$

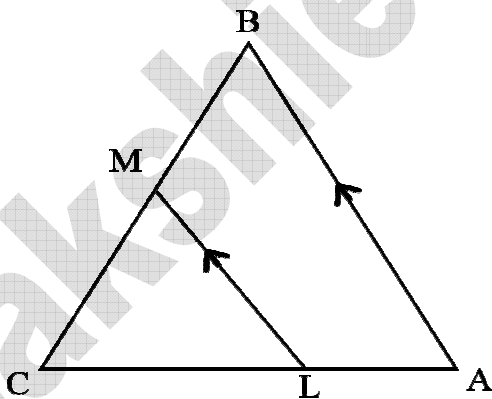

$$\Rightarrow \frac{AL}{LC} = \frac{BM}{MC} \text{ (By Thales Theorem)}$$

$$\frac{x-3}{2x-(x-3)} = \frac{x-2}{(2x+3)-(x-2)}$$

$$\frac{x-3}{(x+3)} = \frac{x-2}{x+5} \text{ (cross multiplication)}$$

$$(x - 3)(x + 5) = (x - 2)(x + 3)$$

$$x^2 + 2x - 15 = x^2 + x - 6$$

$$2x - x = -6 + 15 \Rightarrow x = 9.$$

3. What values of x will make DE//AB in the given figure.

Sol: In $\triangle ABC$, $DE \parallel AB$

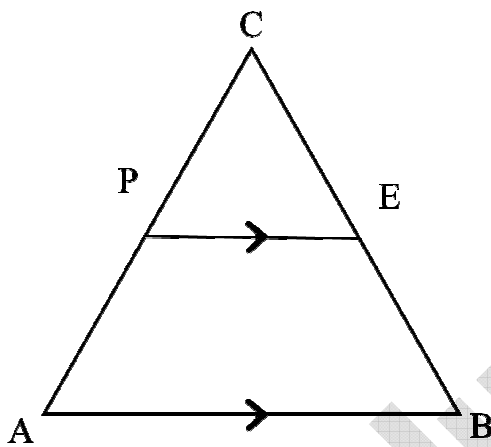

$$\frac{CD}{AD} = \frac{CE}{CB}$$

$$\frac{x+3}{8x+9} = \frac{x}{3x+4}$$

$$(x + 3)(3x + 4) = x(8x + 9)$$

$$3x^2 + 13x + 12 = 8x^2 + 9x$$

$$5x^2 - 4x - 12 = 0$$

$$(x - 2)(5x + 6) = 0 \Rightarrow x = 2; x = \frac{-6}{5}$$

4. In $\triangle ABC$, $DE \parallel BC$, $AD = x$, $DB = x - 2$, $AE = x + 2$ and $EC = x - 1$ Find value of x .

Sol: In $\triangle ABC$, $DE \parallel BC$

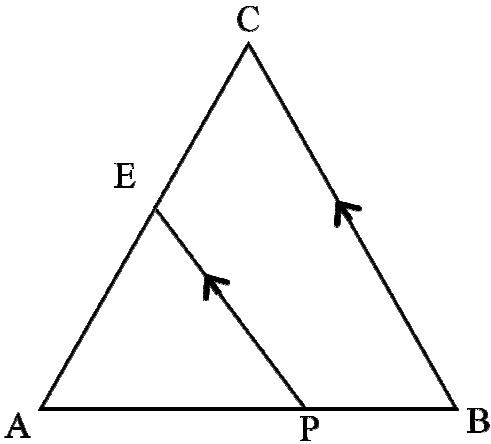

$$\frac{AD}{DB} = \frac{AE}{EC} \text{ (by thales theorem)}$$

$$\frac{x}{x-2} = \frac{x+2}{x-1}$$

$$x(x-1) = (x+2)(x-2)$$

$$x^2 - x = x^2 - 4 \Rightarrow x = 4.$$

5. In $\triangle PQR$, ST is a line such that $\frac{PS}{SQ} = \frac{PT}{TR}$ and $\angle PST = \angle PRQ$ prove that

$\triangle PQR$ is isosceles triangle.

Sol: In $\triangle PQR$, ST is a line such that $\frac{PS}{SQ} = \frac{PT}{TR}$ and $\angle PST = \angle PRQ$

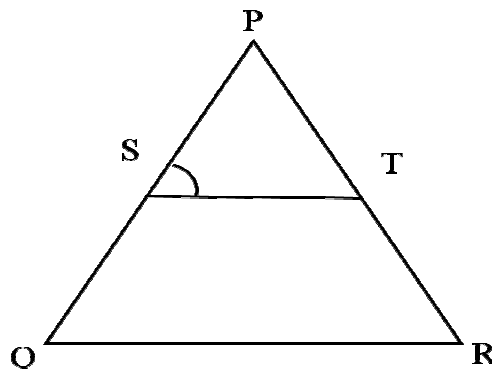

By the converse theorem of Thales,

$$ST \parallel QR$$

$$\Rightarrow \angle PST = \angle PQR \text{ (corresponding angles)} \rightarrow (1)$$

$$\angle PQR = \angle PRQ \text{ (Given)} \rightarrow (2)$$

From (1) and (2) we get

$$\angle PST = \angle PRQ$$

$$\Rightarrow PQ = QR \text{ (sides opposite to the equal angles)}$$

$\therefore \Delta PQR$ is an isosceles triangle

6. Prove that a line drawn through the mid-point of one side of a Triangle parallel to another side bisects the third side (using basic proportionality theorem)

Sol: In ΔABC , D is the mid-point of AB and $DE \parallel BC$

To prove: $AE = EC$

$$\frac{AD}{DB} = \frac{AE}{EC} \text{ (By Thales theorem)} \rightarrow (1)$$

But D is the mid-point of AB

$$\Rightarrow AD = DB$$

$$\frac{AD}{DB} = 1$$

$$\frac{AE}{EC} = 1 \text{ from (1)}$$

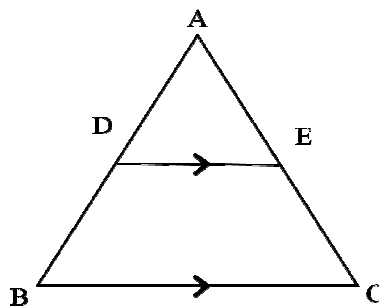

$$\Rightarrow AE = EC$$

AC is bisected by the parallel line.

One Mark Questions

1. **Define regular polygon?**

A. A polygon in which all sides and angles are equal is called a regular polygon.

2. **Write the properties of similar triangles?**

A. Corresponding sides are in the same ratio corresponding angles are equal

3. **Which figures are called similar figures?**

A. The geometrical figures which have same shape but not same size.

4. **Which figures are called congruent figures?**

A. The geometrical figures which have same size and same shape.

5. **When do you say that two triangles are similar?**

A. Two triangles are said to be similar if their

i) Corresponding angles are equal

ii) Corresponding sides are in the same ratio.

6. **Sides of two similar triangles are in the ratio 2:3. Find the ratio of the areas of the triangle**

A. 4 : 9

7. **Write the basic proportionality theorem.**

A. If a line is drawn parallel to one side of a triangle to intersect the other two sides in distinct points, then the other two sides are divided in the same ratio.

8. Write the converse of basic proportionality theorem.

A. If a line divides two sides of a triangle in the same ratio, then the line is parallel to the third side

9. Write AAA axiom.

A. In two triangles, if the angles are equal, then the sides opposite to the equal angles are in the same ratio (or proportion) and hence the two triangles are similar.

10. Write SSS criterion

A. If in two triangles the sides of one triangle are proportional to the sides of the other triangle, then their corresponding angles are equal and hence the triangles are similar.

11. Write SAS criterion.

A. If one angle of a triangle is equal to one angle of another triangle and the sides including these angles are proportional, then the two triangles are similar.

12. State Pythagoras theorem

A. In a right triangle, the square of hypotenuse is equal to the sum of the squares of the other two sides.

13. Which is the longest side in a right triangle?

A. Hypotenuse

14. If the side of an equilateral triangle is 'a' then find height?

A. $\frac{\sqrt{3}}{2}$ a units

Fill in the Blanks

1. In $\triangle ABC$ if $\angle D = 90^\circ$ and $BD \perp AC$ then $BD^2 =$ _____
2. All squares and equilateral triangles are _____
3. Example of similar figures is _____
4. Example of non similar figures is _____
5. If a line divides two sides of a triangle in the same ratio. Then the line is _____ parallel to the _____
6. In $\triangle ABC$, $BC^2 + AB^2 = AC^2$ Then _____ is a right angle
7. If D is the midpoint of BC in $\triangle ABC$ then $AB^2 + AC^2 =$ _____
8. In $\triangle ABC$, D and E are mid points of AB and AC then $DE : BC$ is _____.
9. The diagonal of a square is _____ times to its side
10. If $ABC \sim PQR$ Than $AB : AC$ _____
11. The ratio of corresponding sides of two similar triangles is 3 : 4 Then the _____ ratio of their areas is _____
12. Basic proportionality theorem is also known as _____ theorem
13. Area of an equilateral triangle is _____
14. _____ is the longest side of right angled triangle.

Key

- 1) AD.DC; 2) Similar; 3) Squares of different sizes, any two squares;
- 4) Any two walls, square and rhombus; 5) Third side; 6) $\angle B$;
- 7) $2AD^2 + 2BD^2$; 8) 1 : 2; 9) $\sqrt{2}$; 10) PQ : PR; 11) 9 : 16;
- 12) Thales; 13) $\frac{\sqrt{3}}{4} a^2$; 14) Hypotenuse.

Chapter –10

Mensuration

Cuboid:

l: length, b: breadth, h: height

Lateral Surface Area (LSA) or Curved Surface Area (CSA)

$$= 2h(l+b)$$

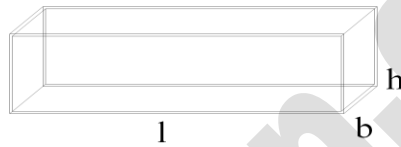

Total Surface Area (TSA) = $2(lb+bh+hl)$

$$\text{Volume} = lbh$$

Cube:

a: Side of the cube

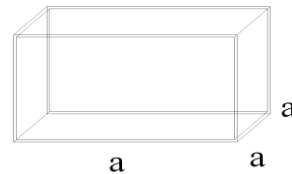

Lateral surface Area (LSA) = $4a^2$

Total surface Area (TSA) = $6a^2$

Volume = a^3

Right Prism:

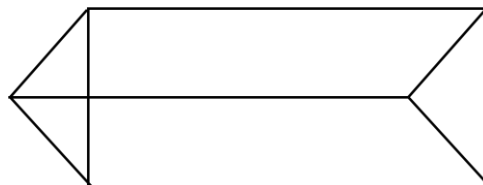

LSA = perimeter of base \times height

TSA = LSA + 2(area of the end surface)

Volume = Area of base \times height

Regular Circular Cylinder

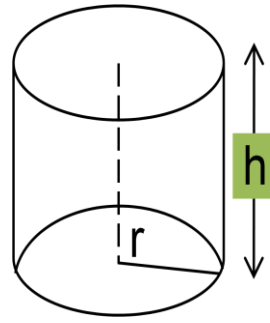

r: radius of the base

h: height

$$\text{LSR} = 2\pi rh$$

$$\text{TSA} = 2\pi r(h+r)$$

$$\text{Volume} = \pi r^2 h$$

Right Pyramid

$$\text{LSA} = \frac{1}{2} (\text{Perimeter of base}) \times \text{slant height}$$

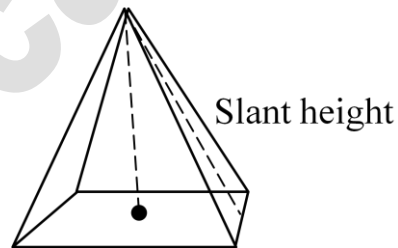

$$\text{TSA} = \text{LSA} + \text{area of the end surface}$$

$$\text{Volume} = \frac{1}{3} \text{Area of base} \times \text{height.}$$

Right circular cone:

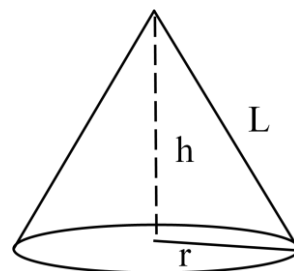

r : radius of the base, h:height ; l: slant height

$$\text{LSA} = \pi r l$$

$$\text{TSA} = \pi r (1 + r)$$

$$\text{Volume} = \frac{1}{3} \pi r^2 h$$

$$\text{Slant height } l = \sqrt{h^2 + r^2}$$

Sphere:

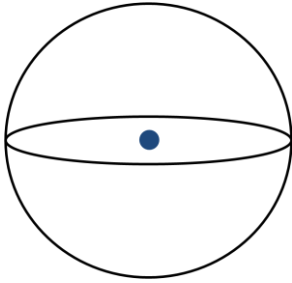

r : radius

$$\text{LSA} = 4\pi r^2$$

$$\text{TSA} = 4\pi r^2$$

$$\text{Volume} = \frac{4}{3} \pi r^3$$

Hemisphere:

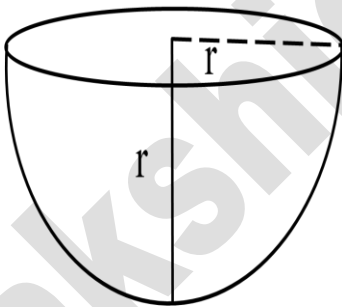

r : radius

$$\text{LSA} = 2 \pi r^2$$

$$\text{TSA} = 3\pi r^2$$

$$\text{Volume} = \frac{2}{3} \pi r^3$$

- If A sphere, a cylinder and a cone are of the same radius and same height then the ratio of their curved surface areas are $4 : 4 : \sqrt{5}$
- If A cylinder and cone have bases of equal radii and are of equal heights, then their volumes are in the ratio of $3 : 1$
- If A sphere is inscribed in a cylinder then the surface of the sphere equal to the curved surface of the cylinder

1 Mark Problems

1. Write the formula to find the volume of cylinder.

A. $\pi r^2 h$

Where r : radius of the base

h : height.

2. Find the ratio between lateral surface area and total surface area of cube?

A. lateral surface area of cube = $4a^2$

Total surface area of cube = $6a^2$

$$4a^2 : 6a^2$$

$$4 : 6$$

$$2 : 3$$

3. The diagonal of a cube is $6\sqrt{3}$ cm then find its lateral surface area?

A. The diagonal of a cube is = $\sqrt{3}a$

$$6\sqrt{3} = \sqrt{3}a$$

$$6 = a$$

Lateral surface area of cube = $4a^2$

$$= 4 \times 6^2$$

$$= 4 \times 6 \times 6$$

$$= 4 \times 36$$

$$= 144 \text{ sq.cm.}$$

4. What is the largest chord of the circle?

A. The 'Diameter' is the largest chord of the circle.

5. Find the volume of a sphere of radius 2.1cm.

A. Volume of sphere $= \frac{4}{3} \pi r^3$

$$= \frac{4}{3} \times \frac{22}{7} \times (2.1)^3$$
$$= \frac{4}{3} \times \frac{22}{7} \times 2.1 \times 2.1 \times 2.1$$
$$= 38.808 \text{ cm}^3.$$

6. Find the total surface area of a hemisphere of diameter 7cm.

A. $r = \frac{7}{2} \text{ cm}$

$$\text{T.S.A} = 3\pi r^2$$
$$= 3 \times \frac{22}{7} \times \frac{7}{2} \times \frac{7}{2}$$
$$= \frac{231}{2}$$
$$= 115.5 \text{ cm}^2.$$

7. What is the lateral surface area of cube.

A. $4a^2$, where a: side of the cube.

8. Find the total surface area of regular circular cylinder.

A. $2\pi r(r + h)$

Where, r : radius of the base

h : height.

9. Find the circumference of a circle of radius 8.4 cm

A. $r = 8.4 \text{ cm}$

Circumference, $c = 2\pi r$

$$= 2 \times \frac{22}{7} \times 8.4 \text{ cm}$$
$$= 52.8 \text{ cm.}$$

10. In a cuboid $l = 5\text{cm}$, $b = 3\text{cm}$, $h = 2\text{cm}$. Find its volume?

A. volume $v = lbh$

$$= 5 \times 3 \times 2$$
$$= 15 \times 2$$
$$= 30 \text{ cm}^3.$$

11. Find the surface area of sphere of radius 2.1cm .

A. Radius of sphere (r) = 2.1cm

$$\text{Surface area of sphere} = 4\pi r^2$$

$$= 4 \times \frac{22}{7} \times (2.1)^2$$
$$= 4 \times \frac{22}{7} \times \frac{21}{10} \times \frac{21}{10}$$
$$= \frac{1386}{25}$$
$$= 55.44 \text{ cm}^2.$$

12. In the figure find r .

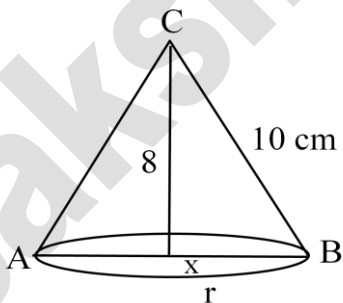

A. $10^2 = 8^2 + r^2$

$$100 = 64 + r^2$$
$$r^2 = 100 - 64$$

$$r^2 = 36$$

$$r = \sqrt{36}$$

$$r = 6$$

$$\therefore r = 6\text{cm.}$$

13. In a hemisphere $r = 8\text{cm}$, find CSA.

A. $r = 8\text{cm}$

$$\text{CSA} = 2\pi r^2$$

$$= 2 \times \frac{22}{7} \times 8 \times 8 \text{ cm}^2$$

$$= \frac{2816}{7} \text{ cm}^2$$

14. The area of the base of a cylinder is 616 sq.cm. Then find its radius

A. The area of the base of a cylinder = 616

We know that area base cylinder = πr^2 .

$$\therefore \pi r^2 = 616$$

$$\frac{22}{7} \times r^2 = 616$$

$$r^2 = 616 \times \frac{7}{22}$$

$$r^2 = 196$$

$$r = \sqrt{196}$$

$$r = 14 \text{ cm.}$$

15. Find T.S.A of a solid hemisphere whose radius is 7cm.

A. Total surface area of hemisphere = $3\pi r^2$

$$= 3 \times \frac{22}{7} \times 7 \times 7$$

$$= 21 \times 22$$

$$= 462 \text{ sqcm.}$$

16. The diagonal of square is $7\sqrt{2}$ cm. Then find its area.

A. The diagonal of a square = $\sqrt{2}.a$, a is the side of a square

$$\sqrt{2}.a = 7\sqrt{2}$$

$$a = \frac{7\sqrt{2}}{\sqrt{2}}$$

$$A = 7$$

$$\text{Area of square} = a \times a$$

$$= 7 \times 7$$

$$= 49 \text{ cm}^2.$$

17.If the ratio of radii of two spheres is 2 : 3. Then find the ratio of their surface areas.

A. Lateral surface area of sphere = $4\pi r^2$

$$\text{Ratio of radii of two spheres} = 2:3 \Rightarrow 2x : 3x$$

$$4\pi (2x)^2 : 4\pi (3x)^2$$

$$4\pi 4x^2 : 4\pi 9x^2$$

$$4 : 9$$

The ratio of surface areas are 4 : 9.

18. Find the surface area of hemispherical bowl whose radius is 21 cm.

A. surface area of Hemisphere = $2\pi r^2$

$$= 2 \times \frac{22}{7} \times 21 \times 21$$

$$= 44 \times 63$$

$$= 2772 \text{ cm}^2.$$

19. Find the T.S.A. of cube whose edge is 1cm.

A. T.S.A of cube = $6a^2 = 6(1)^2$

$$= 6 \text{ cm}^3.$$

2 Marks Problems

1.The radius of a conical tent is 7 meters and its height is 10 meters. Calculate the length of canvas used in making the tent if width of canvas is 2m.

A. If the the radius of conical tent is given (r) = 7 metres

$$\text{Height (h)} = 10\text{m.}$$

$$\therefore \text{ So, the slant height of the cone } l^2 = r^2 + h^2 \Rightarrow l =$$

$$= \sqrt{r^2 + h^2}$$

$$= \sqrt{49 + 100}$$

$$= \sqrt{149} = 12.2\text{m.}$$

Now, surface area of the tent = $\pi r l$

$$= \frac{22}{7} \times 7 \times 12.2\text{m}^2$$

$$= 268.4 \text{ m}^2.$$

$$\text{Area of canvas used} = 268.4\text{m}^2$$

It is given the width of the canvas = 2m.

$$\text{Length of canvas used} = \frac{\text{Area}}{\text{width}} = \frac{268.4}{2} = 134.2\text{cm.}$$

2.An oil drum is in the shape of a cylinder having the following dimensions: diameter is 2m and height is 7 meters. The painter charges Rs. 3 per m² to paint the drum. Find the total charges to be paid to the printer for 10 drums?

A. It is given that diameter of the (oil drum) cylinder = 2 m

$$\text{Radius of cylinder} = \frac{d}{2} = \frac{2}{2} = 1\text{m.}$$

Total surface area of a cylindrical drum = $2 \times \pi r (r + h)$

$$= 2 \times \frac{22}{7} \times 1(1 + 7)$$

$$= 2 \times \frac{22}{7} \times 8$$

$$\frac{352}{7} m^2$$

$$= 50.28 m^2$$

So, the total surface area of a drum = $50.28 m^2$

Painting charge per $1 m^2$ = Rs. 3

Cost of painting of 10 drums = $50.28 \times 3 \times 10$

$$= \text{Rs. } 1508.40.$$

3. A company wanted to manufacture 1000 hemispherical basins from a thin steel sheet. If the radius of hemispherical basin is 21cm, find the required area of steel sheet to manufacture the above hemispherical basins?

A. Radius of the hemispherical basin (r) = 21cm

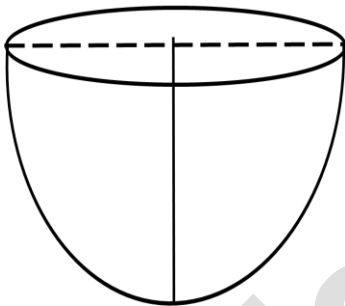

Surface area of a hemispherical basin = $2\pi r^2$

$$= 2 \times \frac{22}{7} \times 21 \times 21$$

$$= 2772 \text{ cm}^2$$

So, surface area of a hemispherical basin = 2772 cm^2

Hence, the steel sheet required for one basin = 2772 cm^2

Total area of steel sheet required for 1000

$$\text{basins} = 2772 \times 1000$$

$$= 2772000 \text{ cm}^2$$

$$= 277.2 m^2.$$

4. Find the volume and surface area of a sphere of radius 2.1cm.

A. Radius of sphere (r) = 2.1 cm

$$\text{Surface area of sphere} = 4\pi r^2$$

$$= 4 \times \frac{22}{7} \times (2.1)^2$$

$$= 4 \times \frac{22}{7} \times \frac{21}{10} \times \frac{21}{10}$$

$$= \frac{1386}{25}$$

$$= 55.44 \text{cm}^2.$$

$$\text{Volume of sphere} = \frac{4}{3}\pi r^3$$

$$= \frac{4}{3} \times \frac{22}{7} \times (2.1)^3$$

$$= \frac{4}{3} \times \frac{22}{7} \times 2.1 \times 2.1 \times 2.1$$

$$= 38.808 \text{cm}^3.$$

5. Find the volume and the total surface area of a hemisphere of radius 3.5cm.

A. Radius of sphere (r) is 3.5 cm = $\frac{7}{2}$ cm

$$\text{Volume of hemisphere} = \frac{2}{3}\pi r^3$$

$$= \frac{2}{3} \times \frac{22}{7} \times \frac{7}{2} \times \frac{7}{2} \times \frac{7}{2}$$

$$= \frac{539}{6}$$

$$= 89.83 \text{ cm}^3$$

$$\text{Total surface area} = 3\pi r^2$$

$$\begin{aligned} &= 3 \times \frac{22}{7} \times \frac{7}{2} \times \frac{7}{2} \\ &= \frac{231}{2} \\ &= 115.5 \text{cm}^2. \end{aligned}$$

6. The lateral surface area of a cylinder is equal to the curved surface area of a cone. If the radius be the same, find the ratio of the height of the cylinder and slant height of the cone.

A. Given, L.S.A of cylinder = C.S.A of the cone.

The dimensions are:

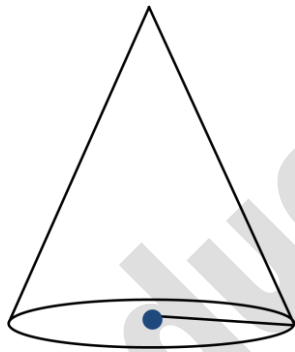
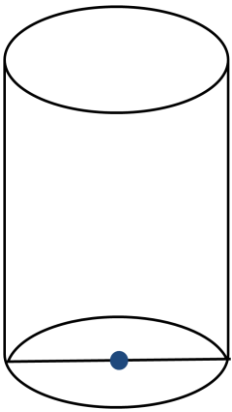

Cylinder

Radius = r

Height = h

L.S.A = $2\pi rh$

If radius is same,

$$2\pi rh = \pi rl$$

$$\Rightarrow \frac{h}{l} = \frac{\pi r}{2\pi r} = \frac{1}{2}$$

$$\Rightarrow h:l = 1:2.$$

cone

Radius = r

slant height = l

C.S.A = πrl

\therefore The ratio of height of cylinder and height of cone is 1: 2.

7. A cylinder and cone have bases of equal radii and are of equal height. Show that their volumes are in the ratio of 3: 1.

A. Given dimensions are:

Cone

Radius = r

Height = h

$$\text{Volume (v)} = \frac{1}{3} \pi r^2 h$$

cylinder

Radius = r

Height = h

$$\text{Volume (v)} = \pi r^2 h$$

$$\text{Ratio of volumes} = \pi r^2 h : \frac{1}{3} \pi r^2 h$$

$$= 1 : \frac{1}{3}$$

$$= 3 : 1$$

Hence, their volumes are in the ratio = 3 : 1.

8. A solid iron rod has a cylindrical shape, its height is 11cm. and base diameter is 7cm. Then find the total volume of 50 rods.

A.

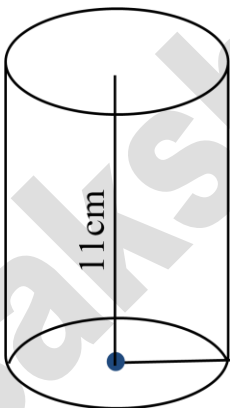

Diameter of the cylinder (d) = 7cm

$$\text{Radius of the base (r)} = \frac{7}{2} = 3.5\text{cm}$$

Height of the cylinder (h) = 11cm

Volume of the cylinder $v = \pi r^2 h$

$$= \frac{22}{7} \times 3.5 \times 3.5 \times 11$$

$$= 423.5 \text{ cm}^3$$

∴ Total volume of 50 rods

$$= 50 \times 423.5 \text{ cm}^3$$

$$= 21175 \text{ cm}^3.$$

9. The curved surface area of a cone is 4070 cm^2 and its diameter is 70cm. What is slant height?

A. The curved surface area of a cone = 4070 cm^2

Its diameter (d) = 70 cm

$$\text{Radius (r)} = \frac{d}{2} = \frac{70}{2}$$

$$= 35 \text{ cm}$$

Now $\pi r l = 4070 \text{ cm}^2$

$$= \frac{22}{7} \times 35 \times l = 4070 \text{ cm}^2$$

$$l = 4070 \times \frac{7}{22} \times \frac{1}{35}$$

$$= 37 \text{ cm}$$

∴ The slant height (l) = 37cm.

10. Two cubes each of volume 64cm^3 are joined end to end together. Find the surface area of the resulting cuboid.

A. volume of cube (v) = 64cm^3

$$S^3 = 64\text{cm}^3 = (4\text{cm})^3$$

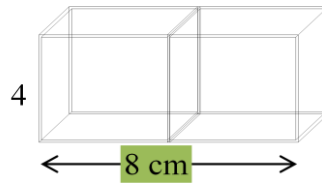

$$\Rightarrow S = 4\text{cm}$$

Length of the cuboid = $4\text{cm} + 4\text{cm}$

$$= 8\text{cm}$$

Surface area of the cuboid

$$= 2(lb + lh + bh)$$

$$= 2 [8 \times 4 + 8 \times 4 + 4 \times 4] \text{ cm}^2$$

$$= 2 [32 + 32 + 16] \text{ cm}^2$$

$$= 160 \text{ cm}^2.$$

12. A hemisphere is cut out from one face of a cubical wooden block such that the diameter of the hemisphere is equal to the length of the cube. Determine the surface area of the remaining solid.

A. Let the length of the edge of the cube = a units

T.S.A of the given solid $d = 5 \times \text{Area of each surface} + \text{Area of hemisphere}$

Square surface:

Side = a units

Area = a^2 sq units

Hemisphere:

Diameter = a units

$$\text{Radius} = \frac{a}{2}$$

$$\text{C.S.A} = 2\pi r^2$$

$$= 2\pi \frac{a^2}{4}$$

$$= \frac{\pi a^2}{2} \text{ sq.units}$$

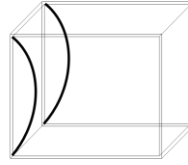

$$\text{Total surface area} = 5a^2 + \frac{\pi a^2}{2}$$

$$= a^2 \left[5 + \frac{\pi}{2} \right] \text{ sq.units.}$$

13. Find the volume of the largest right circular cone that can be cut out of a cube whose edge is 7cm.

A. Radius of the cone with the largest volume that can

be cut from a cube of edge 7cm = $\frac{7}{2}$ cm

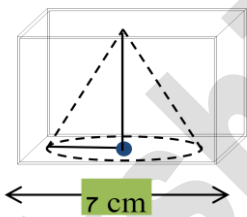

Height of the cone = edge of the cube = 7cm

$$\therefore \text{Volume of the cone } v = \frac{1}{3} \pi r^2 h = \frac{1}{3} \times \frac{22}{7} \times \frac{7}{2} \times \frac{7}{2} \times 7$$

$$= 89.83 \text{ cm}^3$$

14. A cone of height 24cm and radius of base 6cm is made up of modeling clay. A child reshapes it in the form of a sphere. Find the radius of the sphere.

A. volume of cone = $\frac{1}{3} \times \pi \times 6 \times 6 \times 24 \text{ cm}^3$

If r is the radius of the sphere, then its volume is $\frac{4}{3} \pi r^3$

Since the volume of clay is in the form of the same, we have

$$\frac{4}{3} \pi r^3 = \frac{1}{3} \pi \times 6 \times 6 \times 24$$

$$r^3 = \frac{6 \times 6 \times 24}{4}$$

$$r^3 = 6 \times 6 \times 6$$

$$r^3 = 6^3$$

$$r = 6 \text{ cm.}$$

∴ The radius of the sphere is 6cm.

15. A hemispherical bowl of internal radius 15cm. contains a liquid. The liquid is to be filled into cylindrical bottles of diameter 5cm and height 6cm. How many bottles are necessary to empty the bowl?

A. Volume of hemisphere = $\frac{2}{3} \pi r^3$

Internal radius of hemisphere (r) = 15cm

$$\begin{aligned} \therefore \text{Volume liquid contained in hemisphere bowl} &= \frac{2}{3} \times \pi \times (15)^3 \text{ cm}^3 \\ &= 2250\pi \text{ cm}^3 \end{aligned}$$

This liquid is to be filled in cylinder bottles and the height of each bottle (h) = 6cm

$$\text{Radius of cylindrical bottle (R)} = \frac{5}{2} \text{ cm}$$

$$\therefore \text{Volume of 1 cylindrical bottle} = \pi R^2 h$$

$$= \pi \times \left(\frac{5}{2}\right)^2 \times 6$$

$$= \pi \times \frac{25}{4} \times 6 \text{ cm}^3$$

$$= \frac{75}{2} \pi \text{ cm}^3$$

$$\text{Number of cylindrical bottles required} = \frac{\text{volume of hemispherical bowl}}{\text{volume of 1 cylindrical bottle}}$$

$$= \frac{2250\pi}{\frac{75}{2}\pi}$$

$$= \frac{2 \times 2250}{75}$$

$$= 60.$$

16. A metallic sphere of radius 4.2cm is melted and recast into the shape of a cylinder of radius 6cm. Find the height of the cylinder.

A. Let the height, of the cylinder = h cm

Volume of cylinder = volume of sphere

$$= \pi \times 6^2 \times h = \frac{4}{3} \times \pi (4.2)^3 \Rightarrow h = \frac{4}{3} \times \frac{\pi \times 4.2 \times 4.2 \times 4.2}{\pi \times 6 \times 6}$$

$$h = 4 \times 0.7 \times 0.7 \times 1.4$$

$$h = 2.744 \text{ cm.}$$

17. Find the area of required cloth to cover the heap of grain in conical shape whose diameter is 8cm and slant height of 3m.

A. diameter (d) = 8m

$$\text{Radius (r)} = \frac{d}{2} = \frac{8}{2} = 4$$

Slant height (l) = 3

Surface area of cone = πrl

$$\begin{aligned} &= \frac{22}{7} \times 4 \times 3 \\ &= \frac{22 \times 12}{7} = \frac{264}{7} \\ &= 37.71 \end{aligned}$$

Area of the cloth to cover the heap of the grain = 37.71

18. If the total surface area of a cube is 600 sq.cm. Then find its diagonal.

A. Total surface area = $6l^2$

$$6l^2 = 600$$

$$l^2 = \frac{600}{6}$$

$$l = \sqrt{100}$$

$$l = 10$$

Diagonal of cube = $\sqrt{3}l$

$$= \sqrt{3} \times 10$$

Diagonal = $10\sqrt{3}$ cm

19. The diagonal of a cube is $6\sqrt{3}$ cm. Then find its volume.

A. Diagonal of a cube = $\sqrt{3}l$

$$\sqrt{3}l = 6\sqrt{3}$$

$$l = \frac{6\sqrt{3}}{\sqrt{3}} = 6$$

Volume of cube = l^3

$$= 6 \times 6 \times 6$$

Volume = 216 cm^3 .

Extra Problems

1. A sphere, a cylinder and a cone are of the same radius and same height. Find the ratio of their curved surface areas?

A. Let r be the common radius of a sphere, a cone and a cylinder.

Height of sphere = its diameter = $2r$

Then, the height of the cone = height of cylinder = height of sphere = $2r$

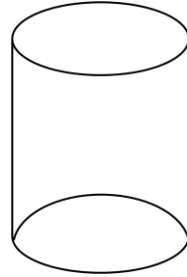

Let l be the slant height of cone = $\sqrt{r^2 + h^2}$

$$= \sqrt{r^2 + (2r)^2}$$

$$= \sqrt{5}r$$

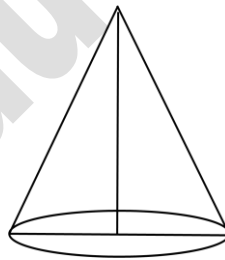

$$\therefore S_1 = \text{curved surface area of sphere} = 4\pi r^2$$

$$S_2 = \text{curved surface area of cylinder} = 2\pi rh = 2\pi r \times 2r$$

$$= 4\pi r^2$$

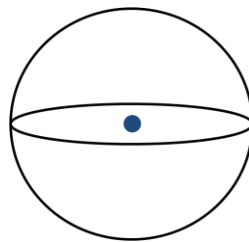

$$S_3 = \text{curved surface area of cone} = \pi rl$$

$$= \pi r \times \sqrt{5}r$$

$$= \sqrt{5} \pi r^2$$

Ratio of curved surface area as

$$\begin{aligned} \therefore S_1 : S_2 : S_3 &= 4\pi r^2 : 4\pi r^2 : \sqrt{5}\pi r^2 \\ &= 4 : 4 : \sqrt{5}. \end{aligned}$$

2. A right circular cylinder has base radius 14cm and height 21cm. Find

(i) Area of base or area of each end

(ii) Curved surface area

(iii) Total surface area

(iv) Volume of the right circular cylinder

A. Radius of the cylinder (r) = 14cm

Height of the cylinder (h) = 21cm

(i) Area of base (area of each end) $\pi r^2 = \frac{22}{7} \times (14)^2$

$$= \frac{22}{7} \times 196$$

$$= 616 \text{ cm}^2$$

(ii) curved surface area = $2\pi rh$

$$= 2 \times \frac{22}{7} \times 14 \times 21$$

$$= 1848 \text{ cm}^2.$$

(iii) Total surface area = $2 \times$ area of the base + curved surface area

$$= 2 \times 616 + 1848$$

$$= 3080 \text{ cm}^2$$

(iv) volume of cylinder = $\pi r^2 h =$ area of the base \times height

$$= 616 \times 21$$

$$= 12936 \text{ cm}^3.$$

3.A joker's cap is in the form of right circular cone whose base radius is 7cm and height is 24cm. Find the area of the sheet required to make 10 such caps.

A. Radius of the base (r) = 7cm

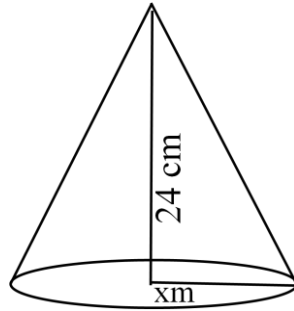

Height of the cone (h) = 24cm

$$\begin{aligned}\therefore \text{Slant height (l)} &= \sqrt{r^2 + h^2} \\ &= \sqrt{7^2 + 24^2} \\ &= \sqrt{49 + 576} \\ &= \sqrt{625} \\ &= 25\text{cm}\end{aligned}$$

Thus, lateral surface area of the joker cap = πrl

$$\begin{aligned}&= \frac{22}{7} \times 7 \times 25 \\ &= 550 \text{ cm}^2\end{aligned}$$

\therefore Total area of the sheet required to make 10 such caps

$$\begin{aligned}&= 10 \times 550 \text{ cm}^2 \\ &= 5500 \text{ cm}^2.\end{aligned}$$

4.A heap of rice is in the form of a cone of diameter 12 m and height 8m. Find its volume? How much canvas cloth is required to cover the heap?

A. Diameter of the conic heap of rice = 12m

$$\therefore \text{Its radius (r)} = \frac{12}{2}m = 6m$$

$$\begin{aligned} \text{Its volume (v)} &= \frac{1}{3}\pi r^2 h \\ &= \frac{1}{3} \times 3.14 \times 6^2 \times 8 \\ &= 301.44m^3 \end{aligned}$$

$$\therefore \text{Volume} = 301.44m^3.$$

$$\begin{aligned} \text{The lateral height (l)} &= \sqrt{r^2 + h^2} \\ &= \sqrt{6^2 + 8^2} \\ &= \sqrt{36 + 64} \\ &= \sqrt{100} \\ &= 10m \end{aligned}$$

Required canvas cloth to cover the heap = curved surface area of heap

$$\begin{aligned} &= \pi r l = 3.14 \times 6 \times 10 \text{ m}^2 \\ &= 188.4m^2 \end{aligned}$$

5.A toy is in the form of a cone mounted on a hemisphere. The diameter of the base and the height of the cone are 6cm and 4cm respectively. Determine the surface area of the toy.

A. Diameter of the cone (d) = 6cm

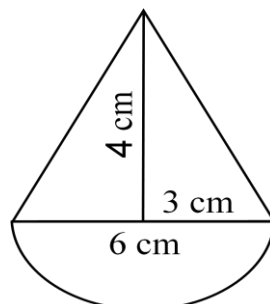

$$\text{Radius of the cone (r)} = \frac{d}{2} = \frac{6}{2} = 3\text{cm}$$

$$\text{Height of the cone (h)} = 4\text{cm}$$

$$\text{Slant height (l)} = \sqrt{r^2 + h^2}$$

$$= \sqrt{3^2 + 4^2}$$

$$= \sqrt{9+16}$$

$$= \sqrt{25}$$

$$= 5\text{cm.}$$

$$\therefore \text{Surface area of cone} = \pi r l$$

$$= 3.14 \times 3 \times 5$$

$$= 47.1 \text{ cm}^2$$

$$\text{Surface area of hemisphere} = 2\pi r^2$$

$$= 2 \times 3.14 \times 3 \times 3$$

$$= 56.52 \text{ cm}^2$$

Thus, total surface area of the toy

$$= \text{SA of cone} + \text{SA of hemisphere}$$

$$= 47.1 \text{ cm}^2 + 56.52 \text{ cm}^2$$

$$= 103.62\text{cm}^2.$$

6.A solid is in the form of a right circular cylinder with a hemisphere at one end and a cone at the other end. The radius of the common base is 8cm and the heights of the cylindrical and conical portions are 10cm and 6cm respectively. Find the total surface area of the solid.

A. Radius of the hemisphere (r) = 8cm

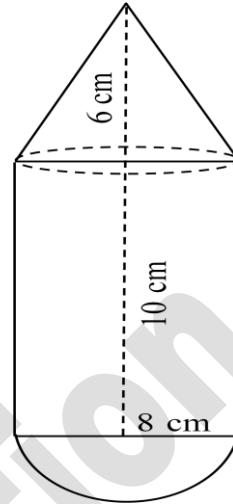

$$\begin{aligned}\text{Surface area of hemisphere} &= 2\pi r^2 \\ &= 2 \times 3.14 \times 8 \times 8 \\ &= 401.92 \text{ cm}^2\end{aligned}$$

$$\text{Height of the cylinder (h)} = 10\text{cm}$$

$$\begin{aligned}\text{Surface area of cylinder} &= 2\pi rh \\ &= 2 \times 3.14 \times 8 \times 10 \\ &= 502.4\text{cm}^2\end{aligned}$$

$$\text{Height of the cone (h)} = 6\text{cm.}$$

$$\begin{aligned}\text{Slant height (l)} &= \sqrt{r^2 + h^2} \\ &= \sqrt{6^2 + 8^2} \\ &= \sqrt{36 + 64} \\ &= \sqrt{100} \\ &= 10 \text{ cm}\end{aligned}$$

$$\text{Surface area of the cone} = \pi rl$$

$$= 3.14 \times 8 \times 10$$

$$= 251.2\text{cm}^2$$

∴ Total surface area of the solid

$$= \text{SA of hemisphere} + \text{SA of cylinder} + \text{SA of cone}$$

$$= 401.92 + 502.4 + 251.2$$

$$= 1155.52\text{cm}^2$$

(If we take $\pi = \frac{22}{7}$ we get 1156.58cm^2)

7.A medicine capsule is in the shape of a cylinder with two hemispheres stuck to each of its ends. The length of the capsule is 14mm and width is 5mm. Find its surface area.

A. length of the cylinder = AB

$$= 14\text{mm} - 2 \times 2.5\text{mm}$$

$$= 14\text{mm} - 5\text{mm} = 9\text{mm}$$

Curved surface area of cylinder = $2\pi rh$

$$= 2 \times \frac{22}{7} \times 2.5 \times 9$$

$$= 141.43 \text{ mm}^2.$$

Curved surface area of hemisphere = $2\pi r^2$

$$= 2 \times \frac{22}{7} \times 2.5 \times 2.5$$

$$= 39.29 \text{ mm}^2.$$

∴ Total surface area of the capsule

$$= \text{CSA of cylinder} + 2 \times \text{CSA of hemisphere}$$

$$= 141.43 \text{ mm}^2 + 2 \times 39.29 \text{ mm}^2$$

$$= 220.01 \text{ mm}^2.$$

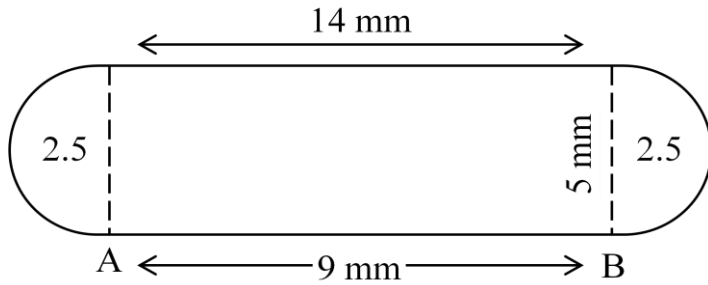

8.A storage tank consists of a circular cylinder with a hemisphere struck on either end. If the external diameter of the cylinder be 1.4m and its length be 8m. Find the cost of painting it on the outside at rate of Rs. 20 per m^2 .

A. The external diameter of the cylinder = 1.4m

$$\therefore \text{Its radius (r)} = \frac{1.4}{2}m = 0.7m$$

Its length or height (h) = 8m

$$\begin{aligned} \text{Curved surface area of each hemisphere} &= 2\pi r^2 \\ &= 2 \times 3.14 \times 0.7 \times 0.7 \\ &= 3.08m^2 \end{aligned}$$

$$\begin{aligned} \text{Curved surface area of cylinder} &= 2\pi rh \\ &= 2 \times 3.14 \times 0.7 \times 8 \\ &= 35.17m^2. \end{aligned}$$

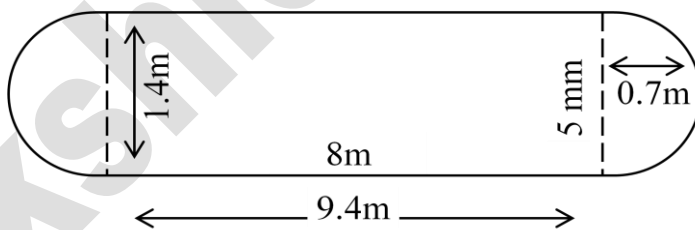

\therefore Total surface area of the storage tank

$$\begin{aligned} &= 35.17m^2 + 2 \times 3.08m^2 \\ &= 35.17m^2 + 6.16m^2 \\ &= 41.33m^2 \end{aligned}$$

The cost of painting it on the outside at rate of Rs 20 per $1m^2$

$$= \text{Rs } 20 \times 41.33$$

$$= \text{Rs. } 826.60.$$

9. A solid toy is in the form of a right circular cylinder with hemispherical shape at one end and a cone at the other end. Their common diameter is 4.2 cm and the height of the cylindrical and conical portions are 12cm and 7cm respectively. Find the volume of the solid toy.

A.

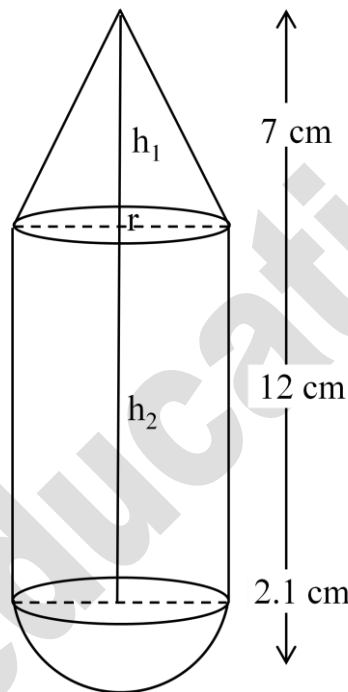

Let height of the conical portion $h_1 = 7\text{cm}$

The height of cylindrical portion $h_2 = 12\text{cm}$

$$\text{radius } (r) = \frac{4.2}{2} = 2.1 = \frac{21}{10} \text{ cm}$$

volume of the solid toy

= volume of the cone + volume of the cylinder + volume of the hemisphere.

$$= \frac{1}{3} \pi r^2 h_1 + \pi r^2 h_2 + \frac{2}{3} \pi r^3$$

$$= \pi r^2 \left[\frac{1}{3} h_1 + h_2 + \frac{2}{3} r \right]$$

$$\begin{aligned}
 &= \frac{22}{7} \times \left[\frac{21}{10} \right]^2 \times \left[\frac{1}{3} \times 7 + 12 + \frac{2}{3} \times \frac{21}{10} \right] \\
 &= \frac{22}{7} \times \frac{441}{100} \times \left[\frac{7}{3} + \frac{12}{1} + \frac{7}{5} \right] \\
 &= \frac{22}{7} \times \frac{441}{100} \times \left[\frac{35 + 180 + 21}{15} \right] \\
 &= \frac{22}{7} \times \frac{441}{100} \times \frac{236}{15} \\
 &= \frac{27258}{125} \\
 &= 218.064 \text{cm}^3.
 \end{aligned}$$

10. A cylindrical container is filled with ice-cream whose diameter is 12cm and height is 15cm. The whole ice-cream is distributed to 10 children in equal cones having hemispherical tops. If the height of the conical portion is twice the diameter of its base find the diameter of the ice-cream cone.

A. Let the radius of the base of conical ice cream = x cm.

∴ Diameter = 2x cm

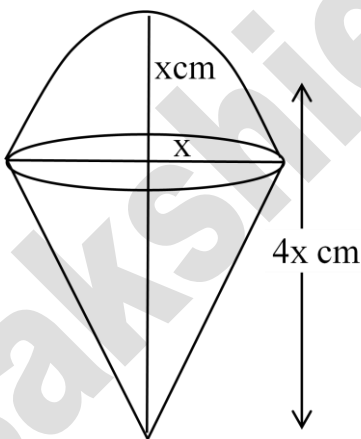

Then, the height of the conical ice-cream

$$= 2(\text{diameter}) = 2(2x) = 4x \text{cm}$$

Volume of ice – cream cone

= volume of conical portion + volume of hemispherical portion

$$= \frac{1}{3} \pi r^2 h + \frac{2}{3} \pi r^3$$

$$= \frac{1}{3} \pi r^2 (4x) + \frac{2}{3} \pi x^3$$

$$= \frac{4\pi x^3 + 2\pi x^3}{3} = \frac{6\pi x^3}{3}$$

$$= 2x^3 \text{ cm}^3$$

Diameter of cylindrical container = 12cm

Its height (h) = 15 cm

∴ Volume of cylindrical container = $\pi r^2 h$

$$= \pi(6)^2(15)$$

$$= 540\pi \text{ cm}^3.$$

Number of children to whom ice-creams is given = 10

$$\frac{\text{volume of cylindrical container}}{\text{volume of one ice - cream cone}} = 10$$

$$\Rightarrow \frac{540\pi}{2\pi x^3} = 10$$

$$\Rightarrow 2\pi x^3 \times 10 = 540\pi$$

$$\Rightarrow x^3 = \frac{540}{2 \times 10} = 27$$

$$\Rightarrow x^3 = 27$$

$$\Rightarrow x^3 = 3^3$$

$$\therefore x = 3$$

∴ Diameter of ice-cream cone $2x = 2(3) = 6\text{cm}$.

11. An iron pillar consists of a cylindrical portion of 2.8m height and 20cm in diameter and a cone of 42cm height surmounting it. Find the weight of the pillar if 1cm³ of iron weighs 7.5g.

A. Height of the cylinder portion = 2.8m

$$= 280 \text{ cm}$$

Diameter of the cylinder = 20cm

$$\text{Radius of the cylinder} = \frac{20}{2} \text{ cm} = 10 \text{ cm}$$

Volume of the cylinder = $\pi r^2 h$

$$= \frac{22}{7} \times 10 \times 10 \times 280 \text{ cm}^3$$

$$= 88000 \text{ cm}^3$$

Height of the cone (h) = 42cm

Radius of the cone (r) = 10cm

Volume of the cone (v) = $\frac{1}{3} \pi r^2 h$

$$= \frac{1}{3} \times \frac{22}{7} \times 10 \times 10 \times 42 \text{ cm}^3$$

$$= 4400 \text{ cm}^3$$

Volume of the pillar

$$= 88000 \text{ cm}^3 + 4400 \text{ cm}^3$$

$$= 92400 \text{ cm}^3$$

Weight of 1cm³ of iron = 7.5g

Weight of the pillar = 7.5 × 92400g

$$= 693000 \text{ g}$$

$$= 693 \text{ kg.}$$

12. A pen stand is made of wood in the shape of cuboid with three conical depressions to hold the pens. The dimensions of the cuboid are 15cm by 10 cm by 3.5 cm. The radius of each of the depressions is 0.5cm and depth is 1.4cm. Find the volume of wood in the entire stand.

A. It is given that the dimensions of the wooden cuboid pen stand are

$$l=15\text{cm}, b = 10\text{cm}, h= 3.5 \text{ cm}$$

$$\text{volume of the cuboid } (v_1) = lbh$$

$$= 15 \times 10 \times 3.5 \text{ cm}^3 = 525 \text{ cm}^3$$

$$\text{Radius of each conical depression } (r) = 0.5\text{cm}$$

$$\text{Depth of each conical depression } (h) = 1.4\text{cm}$$

$$\text{Volume of each conical depression } (v_2) = \frac{1}{3} \pi r^2 h$$

$$= \frac{1}{3} \times \frac{22}{7} \times 0.5 \times 0.5 \times 1.4 \text{ cm}^3$$

$$= 0.367 \text{ cm}^3$$

$$\text{Volume of three conical depressions} = 0.367 \times 3 = 1.101$$

$$\text{Volume of wood in entire stand} = 525 \text{ cm}^3 - 1.101$$

$$= 523.899 = 523.9 \text{ cm}^3$$

13. The diameter of the internal and external surfaces of a hollow hemispherical shell are 6cm and 10cm. Respectively it is melted and recast into a solid cylinder of diameter 14cm. Find the height of the cylinder.

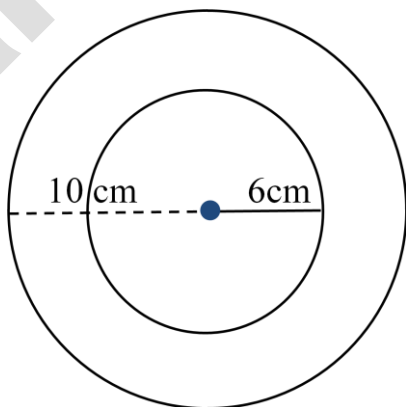

A. Radius of hollow hemispherical shell $= \frac{10}{2} = 5\text{cm} = R$

Internal radius of hollow hemispherical shell $= \frac{6}{2} = 3\text{cm} = r$

Volume of hollow hemispherical shell

= External volume – Internal volume

$$= \frac{2}{3} \pi R^3 - \frac{2}{3} \pi r^3$$

$$= \frac{2}{3} \pi (R^3 - r^3)$$

$$= \frac{2}{3} \pi (5^3 - 3^3)$$

$$= \frac{2}{3} \pi (125 - 27)$$

$$= \frac{2}{3} \pi \times 98\text{cm}^3$$

$$= \frac{196\pi}{3} \text{cm}^3 \rightarrow (1)$$

Since, this hollow hemispherical shell is melted and recast into a solid cylinder. So their volumes must be equal

Diameter of cylinder = 14cm

So, radius of cylinder = 7cm

Let the height of cylinder = h

\therefore volume of cylinder = $\pi r^2 h$

$$= \pi \times 7 \times 7 \times h \text{ cm}^3$$

$$= 49 \pi h \text{ cm}^3 \rightarrow (2)$$

According to given condition

Volume of hollow hemispherical shell = volume of solid cylinder

$$\frac{196}{3} \pi = 49 \pi h \quad \text{[from equation (1) and (2)]}$$

$$h = \frac{196}{3 \times 49}$$

$$h = \frac{4}{3} \text{ cm}$$

Hence, height of the cylinder = 1.33cm.

14. The diameter of a metallic sphere is 6cm. It is melted and drawn into a wire having diameter of the cross section as 0.2cm. Find the length of the wire?

A. We have diameter of metallic sphere = 6cm

∴ Radius of metallic sphere = 3cm.

Also we have,

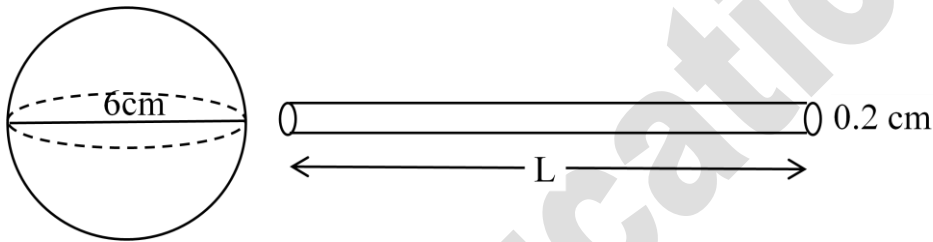

Diameter of cross-section of cylindrical wire = 0.2cm

Radius of cross-section of cylindrical wire = 0.10m

Let the length of wire be 'l' cm.

Since the metallic sphere is covered into a cylindrical shaped wire of length h cm.

∴ volume of the metal used in wire = volume of sphere

$$\pi r^2 h = \frac{4}{3} \pi r^3$$

$$\pi \times (0.1)^2 \times h = \frac{4}{3} \times \pi \times 3^3$$

$$\pi \times \left(\frac{1}{10}\right)^2 \times h = \frac{4}{3} \times \pi \times 27$$

$$\pi \times \frac{1}{100} \times h = \frac{4}{3} \times \pi \times 27$$

$$h = \frac{36\pi \times 100}{\pi}$$

$$h = 3600\text{cm}$$

$$h = 36\text{m.}$$

Therefore the length of wire is 36m.

15. How many spherical balls can be made out of a solid cube of lead whose edge measures 44cm and each ball being 4cm in diameters?

A. Side of lead cube = 44cm

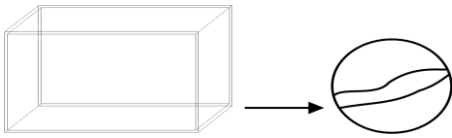

$$\text{Radius of spherical ball} = \frac{4}{2} \text{ cm} = 2\text{cm}$$

$$\begin{aligned} \text{Now, volume of spherical ball} &= \frac{4}{3} \pi r^3 \\ &= \frac{4}{3} \times \frac{22}{7} \times 2^3 \text{ cm}^3 \\ &= \frac{4}{3} \times \frac{22}{7} \times 8 \text{ cm}^3 \end{aligned}$$

$$\text{Volume of } x \text{ spherical ball} = \frac{4}{3} \times \frac{22}{7} \times 8 \times x \text{ cm}^3$$

It is clear that volume of x spherical balls = volume of lead cube

$$\Rightarrow \frac{4}{3} \times \frac{22}{7} \times 8 \times x = (44)^3$$

$$\Rightarrow \frac{4}{3} \times \frac{22}{7} \times 8 \times x = 44 \times 44 \times 44$$

$$x = \frac{44 \times 44 \times 44 \times 3 \times 7}{4 \times 22 \times 8}$$

$$x = 11 \times 11 \times 3 \times 7$$

$$x = 121 \times 21$$

$$x = 2541$$

Hence, total number of spherical balls = 2541.

16. A women self help group (DWACRA) is supplied a rectangular solid (cuboid shape) of wax with diameters 66cm, 42cm, 21cm, to prepare cylindrical candles each 4.2cm in diameters and 2.8cm of height. Find the number of candles.

A. volume of wax in rectangular filed = lbh

$$= (66 \times 42 \times 21) \text{ cm}^3$$

$$\text{Radius of cylindrical bottle} = \frac{4.2}{2} \text{ cm} = 2.1 \text{ cm.}$$

$$\text{Height of the cylindrical candle} = 2.8 \text{ cm.}$$

$$\text{Volume of candle} = \pi r^2 h$$

$$= \frac{22}{7} \times (2.1)^2 \times 2.8$$

$$\text{Volume of } x \text{ cylindrical wax candles} = \frac{22}{7} \times 2.1 \times 2.1 \times 2.8 \times x$$

∴ Volume of x cylindrical candles = volume of wax in rectangular shape

$$\therefore \frac{22}{7} \times 2.1 \times 2.1 \times 2.8 \times x = 66 \times 42 \times 21$$

$$x = \frac{66 \times 42 \times 21 \times 7}{22 \times 2.1 \times 2.1 \times 2.8}$$

$$x = 1500$$

Hence, the number of cylindrical wax candles is 1500

17. Metallic spheres of radius 6cm, 8cm and 10cm, respectively are melted to form a single solid sphere. Find the radius of resulting sphere.

Sol: Radius of first sphere = $(r_1) = 6\text{cm}$.

Radius of second sphere = $(r_2) = 8\text{cm}$.

Radius of third sphere = $(r_3) = 10\text{cm}$

Let the radius of resulting sphere = $r\text{ cm}$

Sum of volumes of 3 spheres = volumes of resulting sphere.

$$\frac{4}{3}\pi r_1^3 + \frac{4}{3}\pi r_2^3 + \frac{4}{3}\pi r_3^3 = \frac{4}{3}\pi r^3$$

$$\frac{4}{3}\pi (r_1^3 + r_2^3 + r_3^3) = \frac{4}{3}\pi r^3$$

$$r_1^3 + r_2^3 + r_3^3 = r^3$$

$$6^3 + 8^3 + 10^3 = r^3$$

$$216 + 512 + 1000 = r^3$$

$$r^3 = 1728$$

$$r^3 = 12^3$$

$$\therefore r = 12\text{cm}.$$

18. A well of diameter 14cm is dug 15m deep. The earth taken out of it has been spread evenly all around it in the shape of a circular ring of width 7cm to form an embankment. Find the height of the embankment.

Sol: Well is in the shape of cylinder.

Depth of well $(b_1) = 15\text{m/s}$

Diameter of well $(d_1) = 14\text{ mm}$

$$\text{Radius } (r_1) = \frac{d_1}{2} = \frac{14}{2} = 7\text{meters}$$

Width of circular ring $(w) = 7\text{ meters}$

Radius of outer circle $(r_2) = r_1 + w = 7 + 7 = 14\text{ m}$

Radius of inner circle (r_1) = 7 mts

Radius of the earth taken from well = volume of circular ring

$$\Rightarrow \pi \times r_1^2 \times h_1 = \pi (r_2^2 - r_1^2) \times h_2$$

$$\Rightarrow \frac{22}{7} \times 7^2 \times 15 = \frac{22}{7} (14^2 - 7^2) \times h_2$$

$$\Rightarrow \frac{22}{7} \times 49 \times 15 = \frac{22}{7} (196 - 49) \times h_2$$

$$\Rightarrow 49 \times 15 = 147 \times h_2$$

$$\Rightarrow h_2 = \frac{49 \times 15}{147}$$

$$\Rightarrow h_2 = 5 \text{ meters.}$$

19. How many silver coins 1.75 cm in diameter and thickness 2mm, need to be melted to form a cuboid of dimensions 5.5cm × 10 cm × 3.5cm?

Sol: Let the number of silver coins needed to melt = n

Then total volume of n coins = volume of the cuboid.

$$n \times \pi r^2 h = lbh$$

[∵ The shape of the coin is

a cylinder and $v = \pi r^2 h$]

$$n \times \frac{22}{7} \times \left[\frac{1.75}{2} \right]^2 \times \frac{2}{10} = 5.5 \times 10 \times 3.5$$

$$\left[\because 2\text{mm} = \frac{2}{10} \text{cm}, r = \frac{d}{2} \right]$$

$$n = 55 \times 3.5 \times \frac{7 \times 2 \times 2 \times 10}{22 \times 1.75 \times 1.75 \times 2}$$

$$= \frac{55 \times 35 \times 7 \times 4}{22 \times 2 \times 1.75 \times 1.75}$$

$$= \frac{5 \times 35 \times 7}{1.75 \times 1.75}$$

$$= \frac{175 \times 7}{1.75 \times 1.75} = \frac{100 \times 1}{0.25} = 400$$

∴ 400 silver coins are needed.

20. A solid metallic sphere of diameter 28cm is melted and recast into a number of smaller cones, each of diameters $4\frac{2}{3}$ cm and height 3cm. Find the number of cones so formed.

Sol: let the no. of small cones = n

Then, total volume of n cones = volume of sphere

Diameter = 28cm

Cones:

$$\text{Radius, } r = \frac{\text{diameter}}{2}$$

$$= \frac{4\frac{2}{3}}{2} = \frac{\frac{14}{3}}{2} = \frac{7}{3} \text{ cm}$$

Height, h = 3cm

$$\text{Volume, } v = \frac{1}{3} \pi r^2 h$$

$$= \frac{1}{3} \times \frac{22}{7} \times \frac{7}{3} \times \frac{7}{3} \times 3$$

$$= \frac{22 \times 7}{3 \times 3} = \frac{154}{9} \text{ cm}^3$$

$$\text{Total volume of n-cones} = n \cdot \frac{154}{9} \text{ cm}^3$$

Sphere:

$$\text{Radius, } r = \frac{d}{2} = \frac{28}{2} = 14 \text{ cm}$$

$$\text{Volume, } v = \frac{4}{3} \pi r^3$$

$$= \frac{4}{3} \times \frac{22}{7} \times 14 \times 14 \times 14$$

$$= \frac{88 \times 28 \times 14}{3} \text{ cm}^3$$

$$\therefore n \cdot \frac{154}{9} = \frac{88 \times 28 \times 14}{3}$$

$$n = \frac{88 \times 28 \times 14}{3} \times \frac{9}{154} = 672$$

\therefore No. of cones formed $n = 672$.

sakshieducation.com

Multiple Choices

1. Area of circle with d as diameter is _____ sq.units []
A) $\frac{\pi d^2}{4}$ B) πr^2 C) $\frac{\pi d^3}{2}$ D) None
2. Number of diameters of a circle is _____ []
A) 2 B) 3 C) 4 D) infinite
3. The ratio between the volume of a cone and a cylinder is []
A) 1 : 2 B) 2 : 1 C) 1 : 3 D) None
4. Heap of stones is example of _____ []
A) circle B) cone C) triangle D) curve
5. Volume of a cylinder = 88cm^3 , $r = 2\text{cm}$ then $h =$ _____ cm []
A) 8.5 B) 7 C) 6.4 D) None
6. Area of Ring = _____ []
A) $R^2 - r^2$ B) $\pi(R^2 - r^2)$ C) $\pi(R^2 + r^2)$ D) None
7. Book is an example of _____ []
A) cube B) cuboid C) Cone D) cylinder
8. The edge of a pencil gives an idea about []
A) curve B) secant C) cone D) cylinder
9. In a cylinder $d = 40\text{cm}$, $h = 56\text{cm}$ then $\text{CSA} =$ _____ cm^2 []
A) 7040 B) 70.40 C) 704 D) None
10. If each side of a cube is doubled then its volume becomes _____ times []
A) 6 B) 2 C) 8 D) 6.0
11. $r = 2.1\text{cm}$ then volume of the sphere is _____ cm^3 []
A) 19.45 B) 55.44 C) 38.88 D) None

12. The volume of right circular cone with radius 6cm and height 7cm is _____ cm^3 []
- A) 164 B) 264 C) 816 D) None
13. Laddu is in _____ shape []
- A) circular B) spherical C) conical D) None
14. In a cylinder $r = 1 \text{ cm}$, $h = 7 \text{ cm}$, then TSA = _____ cm^2 []
- A) 53.18 B) 51.09 C) 99.28 D) 50.28
15. The base of a cylinder is _____ []
- A) triangle B) pentagon C) circle D) None
16. In a cylinder $r = 10 \text{ cm}$, $h = 280 \text{ cm}$ then volume = _____ cm^3 []
- A) 88000 B) 8800 C) 880 D) None
17. Volume of cube is 1728 cm^3 then its edge is _____ cm []
- A) 21 B) 18 C) 12 D) 16
18. If d is the diameter of a sphere then its volume is _____ cubic units []
- A) $\frac{1}{6} \pi d^3$ B) $\frac{1}{12} \pi d^3$ C) $\frac{1}{9} \pi r^3$ D) All
19. Volume of cylinder is _____ []
- A) $\pi r^2 h$ B) $\pi^2 r h^2$ C) $2\pi r h$ D) $2\pi r (r + h)$
20. Circumference of semi circle is _____ units []
- A) $\frac{22}{7} r$ B) $2\pi r$ C) πr^2 D) $\frac{\pi r^2}{2}$

Key:

1. A; 2. D; 3. C; 4. B; 5. B; 6. B; 7. B;
8. C; 9. A; 10. C; 11. C; 12. B; 13. B; 14. D;
15. C; 16. A; 17. C; 18. A; 19. A; 20. A.

Bit Blanks

1. The area of the base of a cylinder is 616 sq.units then its radius is _____
2. Volume of hemisphere is _____
3. T.S.A of a cube is 216cm^2 then volume is _____ cm^3
4. In a square the diagonal is _____ times of its side.
5. Volume of sphere with radius r units is _____ cubic units.
6. In the cone $l^2 =$ _____
7. Number of radii of a circle is _____
8. Number of a edges of a cuboid is _____
9. Diagonal of a cuboid is _____
10. In a hemisphere $r = 3.5\text{cm}$ Then L.S.A = _____ cm^2
11. L.S.A of cone is _____
12. Rocket is a combination of _____ and _____
13. Volume of cone is _____ (or) _____
14. The surface area of sphere of radius 2.1 cm is _____ cm^2
15. In a cone $r = 7\text{cm}$, $h = 21\text{cm}$ Then $l =$ _____ cm
16. The base area of a cylinder is 200 cm^2 and its height is 4cm then its volume is _____ cm^3
17. The diagonal of a square is $7\sqrt{2}\text{cm}$. Then its area is _____ cm^2
18. The ratio of volume of a cone and cylinder of equal diameter and height is _____
19. In a cylinder $r = 1.75\text{cm}$, $h = 10\text{cm}$, then CSA = _____ cm^2
20. T.S.A of cylinder is _____ sq.units.

Key:

1) 14cm; 2) $\frac{2}{3}\pi r^3$; 3) 216; 4) $\sqrt{2}$; 5) $\frac{4}{3}\pi r^3$;

6) $r^2 + h^2$; 7) infinite; 8) 12; 9) $\sqrt{l^2 + b^2 + h^2}$;

10) 77; 11) $\pi r l$; 12) cone, cylinder;

13) $\frac{1}{3} \times \text{volume of cylinder}, \frac{1}{3} \times \pi r^2 h$; 14) 55.44; 15) $\sqrt{490}$;

16) 800; 17) 49; 18) 1 : 3; 19) 110; 20) $2\pi r(h + r)$.

Chapter –11

Trigonometry

In a right triangle ABC as show in the figure

AC is called hypotenuse.

BC is called “Opposite side of $\angle A$ ”

AB is called “Adjacent side of the $\angle A$ ”.

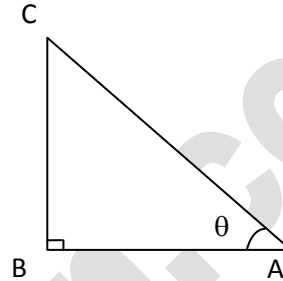

Ratios in A Right Angle Triangle:

$$\sin A = \frac{\text{opposite side of } \angle A}{\text{Hypotenuse}} = \frac{BC}{AC}$$

$$\cos A = \frac{\text{adjacent side of } \angle A}{\text{Hypotenuse}} = \frac{AB}{AC}$$

$$\tan A = \frac{\text{opposite side of } \angle A}{\text{Adjacent side of } \angle A} = \frac{BC}{AB}$$

$$\sec A = \frac{\text{hypotenuse}}{\text{adjacent side of } \angle A} = \frac{AC}{AB} = \frac{1}{\cos A}$$

$$\operatorname{cosec} A = \frac{\text{hypotenuse}}{\text{opposite side of } \angle A} = \frac{AC}{BC} = \frac{1}{\sin A}$$

$$\cot A = \frac{\text{Adjacent side of } \angle A}{\text{opposite side of } \angle A} = \frac{AB}{BC} = \frac{1}{\tan A}$$

Note: We observe that $\tan A = \frac{\sin A}{\cos A}$ and $\cot A = \frac{\cos A}{\sin A}$

Trigonometric ratios of some specific angles:

$\angle A$	0°	30°	45°	60°	90°
Sin A	0	$\frac{1}{2}$	$\frac{1}{\sqrt{2}}$	$\frac{\sqrt{3}}{2}$	1
Cos A	1	$\frac{\sqrt{3}}{2}$	$\frac{1}{\sqrt{2}}$	$\frac{1}{2}$	0
Tan A	0	$\frac{1}{\sqrt{3}}$	1	$\sqrt{3}$	Not defined
Cot A	Not defined	$\sqrt{3}$	1	$\frac{1}{\sqrt{3}}$	0
Sec A	1	$\frac{2}{\sqrt{3}}$	$\sqrt{2}$	2	Not defined
Cosec A	Not defined	2	$\sqrt{2}$	$\frac{2}{\sqrt{3}}$	1

- The value of $\sin A$ will be increased from 0° to 90°
- The value of $\cos A$ will decreased from 0° to 90°
- If one of the trigonometric ratios of an acute angle is known, the remaining trigonometric ratios of the angle can be determined
- The value of $\sin A$ or $\cos A$ never exceeds, where as the value of $\sec A$ or $\text{Cosec} A$ is always greater than or equal to 1.

Trigonometric ratios of complementary angles:

$$\sin (90^\circ - A) = \cos A \quad \text{Cosec} (90^\circ - A) = \sec A$$

$$\cos (90^\circ - A) = \sin A \quad \sec (90^\circ - A) = \text{cosec} A$$

$$\tan (90^\circ - A) = \cot A \quad \cot (90^\circ - A) = \tan A$$

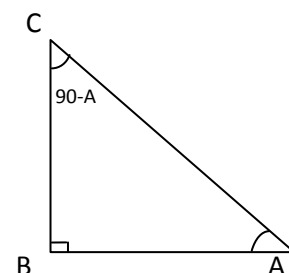

Exercise 11.1

1. In a right angle triangle ABC, 8cm, 15cm and 17cm are the lengths of AB, BC and CA respectively. Then, find out sinA, cosA and tanA.

A. In $\triangle ABC$, $AB = 8\text{cm}$

$$BC = 15\text{ cm}$$

$$AC = 17\text{ cm}$$

$$\sin A = \frac{\text{opposite side}}{\text{Hypotenuse}} = \frac{BC}{AC} = \frac{15}{17}$$

$$\cos A = \frac{\text{Adjacent side}}{\text{Hypotenuse}} = \frac{AB}{AC} = \frac{8}{17}$$

$$\tan A = \frac{\text{opposite side}}{\text{Hypotenuse}} = \frac{BC}{AB} = \frac{15}{8}$$

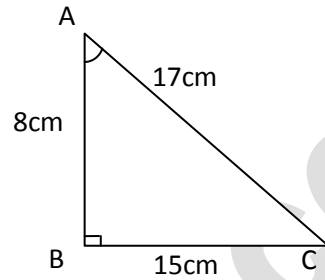

2. The sides of a right angle triangle PQR are PQ = 7cm, QR = 25cm

$\angle P = 90^\circ$ respectively then find tanQ – tanR.

Sol: Given that in PQR,

$$PQ = 7\text{cm and } QR = 25\text{ cm.}$$

$\triangle PQR$ is a right angle triangle

By using Pythagoras theorem

$$PR = \sqrt{QR^2 - PQ^2}$$

$$= \sqrt{(25)^2 - (7)^2} = \sqrt{625 - 49}$$

$$= \sqrt{576} = 24\text{cm.}$$

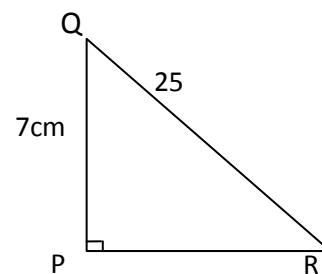

$$\therefore \tan Q = \frac{PR}{PQ} = \frac{24}{7}$$

$$\tan R = \frac{PQ}{PR} = \frac{7}{24}$$

$$\therefore \tan Q - \tan R = \frac{24}{7} - \frac{7}{24} = \frac{576 - 49}{168} = \frac{527}{168}$$

3. In a right angle triangle ABC with right angle at B, in which a = 24 units, b = 25 units and $\angle BAC = \theta$. Then find $\cos \theta$ and $\tan \theta$.

A. In a right angle triangle ABC $\angle B = 90^\circ$, $\angle BAC = \theta$.

a = BC = 24 units and b = AC = 25 units.

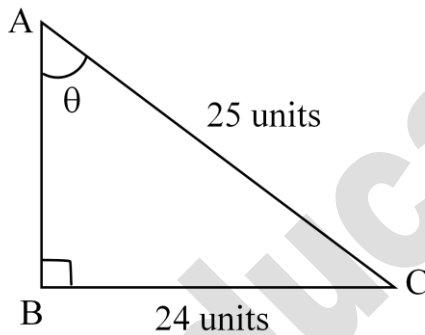

By using Pythagoras theorem

$$AB = \sqrt{AC^2 - BC^2} = \sqrt{(25)^2 - (24)^2} = \sqrt{625 - 576}$$

$$\therefore C = AB = \sqrt{49} = 7 \text{ cm.}$$

$$\text{Then } \cos \theta = \frac{AB}{AC} = \frac{7}{25}$$

$$\tan \theta = \frac{BC}{AB} = \frac{24}{7}$$

4. If $\cos A = \frac{12}{13}$, then find $\sin A$ and $\tan A$.

A. Given that $\cos A = \frac{12}{13} = \frac{BA}{AC}$

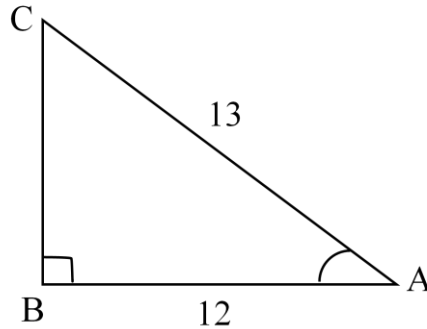

$$\frac{BA}{12} = \frac{AC}{13} = K(\text{say}).$$

Where k is a positive number $BA = 12k$

$$AC = 13K$$

By using Pythagoras theorem $BC = \sqrt{AC^2 - BA^2}$

$$BC = \sqrt{(13k)^2 - (12k)^2} = \sqrt{169k^2 - 144k^2} = \sqrt{25k^2} = 5k$$

$$\therefore \sin A = \frac{BC}{AC} = \frac{5k}{13k} = \frac{5}{13}$$

$$\tan A = \frac{BC}{AB} = \frac{5k}{12k} = \frac{5}{12}$$

5. If $3 \tan A = 4$, Then find $\sin A$ and $\cos A$.

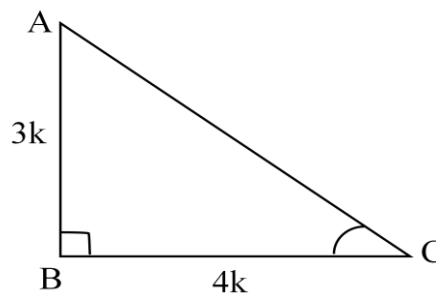

A. Given that $3 \tan A = 4$

$$\Rightarrow \tan A = \frac{4}{3} = \frac{BC}{AB}$$

$$\Rightarrow \frac{BC}{AB} = \frac{4}{3} \text{ say.}$$

$$\frac{BC}{4} = \frac{AB}{3} = k \text{ say. for any positive integer } k.$$

$$BC = 4k \text{ and } AB = 3k$$

By using Pythagoras theorem

$$AC^2 = AB^2 + BC^2$$

$$= (3k)^2 + (4k)^2$$

$$= 9k^2 + 16k^2$$

$$AC^2 = 25k^2$$

$$\therefore AC = 5k.$$

$$\text{Now, } \sin A = \frac{BC}{AC} = \frac{4k}{5k} = \frac{4}{5}.$$

$$\cos A = \frac{AB}{AC} = \frac{3k}{5k} = \frac{3}{5}.$$

6. If $\angle A$ and $\angle X$ are acute angles such that $\cos A = \cos X$, then show that

$$\angle A = \angle X.$$

Sol: Let us consider two right angled triangles $\triangle ABC$ and $\triangle XYZ$ and right angles at $\angle B$ and $\angle Y$ respectively.

$$\text{Given that } \cos A = \cos x$$

From $\triangle ABC$

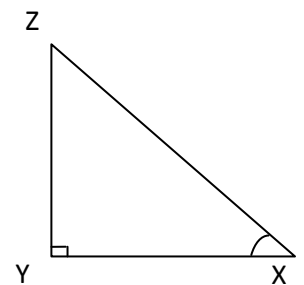
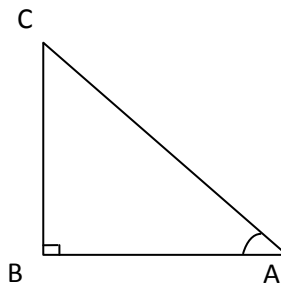

$$\cos A = \frac{AB}{AC} \longrightarrow (1)$$

From $\triangle XYZ$

$$\cos X = \frac{XY}{XZ} \longrightarrow (2)$$

From (1) & (2) $\frac{AB}{AC} = -\frac{XY}{XZ}$ ($\because \cos A = \cos X$)

$$\text{Let } \frac{AB}{AC} = \frac{XY}{XZ} = \frac{K}{1} \Rightarrow \frac{AB}{XY} = \frac{AC}{XZ} = k \longrightarrow (3)$$

$$\frac{BC}{YZ} = \frac{\sqrt{AC^2 - AB^2}}{\sqrt{XZ^2 - XY^2}} \quad (\because \text{By pythagoras theorem})$$

$$= \frac{\sqrt{K^2 XZ^2 - K^2 XY^2}}{\sqrt{XZ^2 - XY^2}} = \frac{K \sqrt{XZ^2 - XY^2}}{\sqrt{XZ^2 - XY^2}} = K$$

$$\therefore \frac{AB}{XY} = \frac{AC}{XZ} = \frac{BC}{YZ}$$

$$\Rightarrow \triangle ABC \sim \triangle XYZ$$

$$\Rightarrow \angle A = \angle X \text{ Proved.}$$

7. Given $\cos \theta = \frac{7}{8}$, then evaluate

(i) $\frac{(1 + \sin \theta)(1 - \sin \theta)}{(1 + \cos \theta)(1 - \cos \theta)}$

(ii) $\frac{1 + \sin \theta}{\cos \theta}$.

Sol: let us draw a right angle triangle ABC in which $\angle BAC = \theta$.

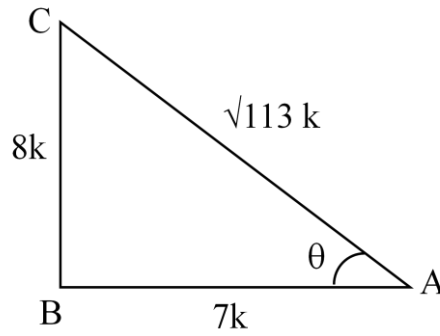

$$\cot \theta = \frac{7}{8} \text{ (Given)}$$

$$\Rightarrow \frac{AB}{BC} = \frac{7}{8}$$

$$\Rightarrow \frac{AB}{7} = \frac{BC}{8} = k \text{ (Say) where } k \text{ is a positive integer.}$$

$$\Rightarrow AB = 7k \text{ and } BC = 8k.$$

By using Pythagoras Theorem $AC = \sqrt{AB^2 + BC^2}$

$$\begin{aligned} &= \sqrt{(7k)^2 + (8k)^2} \\ &= \sqrt{49k^2 + 64k^2} = \sqrt{113}k. \end{aligned}$$

$$\therefore \sin \theta = \frac{BC}{AC} = \frac{8k}{\sqrt{113}k} = \frac{8}{\sqrt{113}}$$

$$\cos \theta = \frac{AB}{AC} = \frac{7k}{\sqrt{113}k} = \frac{7}{\sqrt{113}}$$

$$(i) \quad \frac{(1 + \sin \theta)(1 - \sin \theta)}{(1 + \cos \theta)(1 - \cos \theta)} = \frac{(1)^2 - \sin^2 \theta}{(1)^2 - \cos^2 \theta} = \frac{1 - \left(\frac{8}{\sqrt{113}}\right)^2}{1 - \left(\frac{7}{\sqrt{113}}\right)^2}$$

$$\Rightarrow \frac{1 - \frac{64}{113}}{1 - \frac{49}{113}} = \frac{113 - 64}{113 - 49} = \frac{49}{64}.$$

$$(ii) \frac{1 + \sin \theta}{\cos \theta}$$

$$\Rightarrow \frac{1 + \frac{8}{\sqrt{113}}}{\frac{7}{\sqrt{113}}} = \frac{\sqrt{113} + 8}{7}$$

8. In a right angle triangle ABC, right angle at B, if $\tan A = \sqrt{3}$. Then find the value of

(i) $\sin A \cos C + \cos A \sin C$. (ii) $\cos A \cos C - \sin A \sin C$.

Sol: let us draw a right angled triangle ABC.

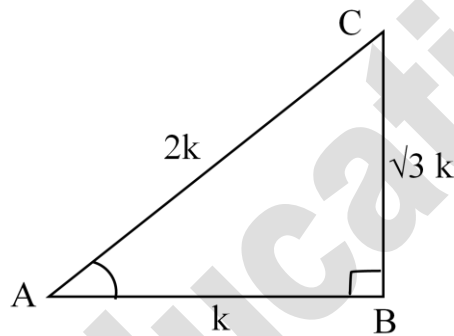

Given that $\tan A = \sqrt{3} = \frac{\sqrt{3}}{1}$, $B = 90^\circ$.

$$\Rightarrow \frac{BC}{AB} = \frac{\sqrt{3}}{1}$$

$$\Rightarrow \frac{BC}{\sqrt{3}} = \frac{AB}{1} = k \text{ say.}$$

Where k is any positive integer

$$\Rightarrow BC = \sqrt{3}k, AB = k.$$

By using Pythagoras theorem $AC = \sqrt{AB^2 + BC^2}$

$$= \sqrt{k^2 + (\sqrt{3}k)^2}$$

$$\sqrt{4k^2} = 2k.$$

$$\therefore AC = 2k.$$

$$\text{There fore } \sin A = \frac{BC}{AC} = \frac{\sqrt{3}k}{2k} = \frac{\sqrt{3}}{2}$$

$$\cos A = \frac{AB}{AC} = \frac{k}{2k} = \frac{1}{2}.$$

$$\sin C = \frac{AB}{AC} = \frac{k}{2k} = \frac{1}{2}; \quad \cos C = \frac{BC}{AC} = \frac{\sqrt{3}k}{2k} = \frac{\sqrt{3}}{2}$$

Now (i) $\sin A \cos C + \cos A \sin C$

$$= \frac{\sqrt{3}}{2} \cdot \frac{\sqrt{3}}{2} + \frac{1}{2} \cdot \frac{1}{2} = \frac{3}{4} + \frac{1}{4} = 1$$

(ii) $\cos A \cos C - \sin A \sin C$

$$= \frac{1}{2} \cdot \frac{\sqrt{3}}{2} - \frac{\sqrt{3}}{2} \cdot \frac{1}{2} = 0.$$

Exercise - 11.2

1. Evaluate the following.

(i) $\sin 45^\circ + \cos 45^\circ$

Sol: we know that $\sin 45^\circ = \frac{1}{\sqrt{2}}$ and $\cos 45^\circ = \frac{1}{\sqrt{2}}$.

$$\therefore \sin 45^\circ + \cos 45^\circ = \frac{1}{\sqrt{2}} + \frac{1}{\sqrt{2}} = \frac{2}{\sqrt{2}} = \sqrt{2}$$

(ii) $\frac{\cos 45^\circ}{\sec 30^\circ + \csc 60^\circ}$

$$= \frac{\frac{1}{\sqrt{2}}}{\frac{2}{\sqrt{3}} + \frac{2}{\sqrt{3}}} = \frac{\frac{1}{\sqrt{2}}}{\frac{2+2}{\sqrt{3}}} = \frac{1}{\sqrt{2}} \times \frac{\sqrt{3}}{2+2}$$

$$= \frac{\sqrt{3}}{4\sqrt{2}}$$

(iii) $\frac{\sin 30^\circ + \tan 45^\circ - \csc 60^\circ}{\cot 45^\circ + \cos 60^\circ - \sec 30^\circ}$

We know that $\sin 30^\circ = \frac{1}{2}$, $\tan 45^\circ = 1$, $\csc 60^\circ = \frac{2}{\sqrt{3}}$

$$\cot 45^\circ = 1; \cos 60^\circ = \frac{1}{2}; \sec 30^\circ = \frac{2}{\sqrt{3}}$$

$$\therefore \frac{\sin 30^\circ + \tan 45^\circ - \csc 60^\circ}{\cot 45^\circ + \cos 60^\circ - \sec 30^\circ} = \frac{\frac{1}{2} + 1 - \frac{2}{\sqrt{3}}}{1 + \frac{1}{2} - \frac{2}{\sqrt{3}}} = 1$$

(iv) $2 \tan^2 45^\circ + \cos^2 30^\circ - \sin^2 60^\circ$

A. $\tan 45^\circ = 1; \cos 30^\circ = \frac{\sqrt{3}}{2}; \sin 60^\circ = \frac{\sqrt{3}}{2}$.

$$\begin{aligned} \therefore 2 \tan^2 45^\circ + \cos^2 30^\circ - \sin^2 60^\circ \\ = 2(1)^2 + \left(\frac{\sqrt{3}}{2}\right)^2 - \left(\frac{\sqrt{3}}{2}\right)^2 = 2 + \frac{3}{4} - \frac{3}{4} = 2. \end{aligned}$$

$$(v) \frac{\sec^2 60^\circ - \tan^2 60^\circ}{\sin^2 30^\circ + \cos^2 30^\circ}$$

$$A. \sec 60^\circ = 2, \tan 60^\circ = \sqrt{3}$$

$$\sin 30^\circ = \frac{1}{2}, \cos 30^\circ = \frac{\sqrt{3}}{2}$$

$$\therefore \frac{\sec^2 60^\circ - \tan^2 60^\circ}{\sin^2 30^\circ + \cos^2 30^\circ} = \frac{(2)^2 - (\sqrt{3})^2}{\left(\frac{1}{2}\right)^2 + \left(\frac{\sqrt{3}}{2}\right)^2} = \frac{4-3}{\frac{1}{4} + \frac{3}{4}} = \frac{1}{1} = 1.$$

2. Evaluate $\sin 60^\circ \cdot \cos 30^\circ + \sin 30^\circ \cos 60^\circ$. What is the value of $\sin (60^\circ + 30^\circ)$. What can you conclude?

$$A. \text{ We know that } \sin 60^\circ = \frac{\sqrt{3}}{2} \quad \sin 30^\circ = \frac{1}{2}$$

$$\cos 60^\circ = \frac{1}{2} \quad \cos 30^\circ = \frac{\sqrt{3}}{2}.$$

$$\therefore \sin 60^\circ \cdot \cos 30^\circ + \sin 30^\circ \cos 60^\circ$$

$$= \frac{\sqrt{3}}{2} \cdot \frac{\sqrt{3}}{2} + \frac{1}{2} \cdot \frac{1}{2} = \frac{3}{4} + \frac{1}{4} = \frac{4}{4} = 1.$$

$$\sin (60^\circ + 30^\circ) = \sin (90^\circ) = 1$$

\therefore we can conclude that

$$\sin (60^\circ + 30^\circ) = \sin 60^\circ \cos 30^\circ + \sin 30^\circ \cos 60^\circ$$

$$\Rightarrow \sin (A + B) = \sin A \cos B + \cos A \sin B.$$

3. Is it right to say $\cos (60^\circ + 30^\circ) = \cos 60^\circ \cos 30^\circ - \sin 60^\circ \sin 30^\circ$.

Sol. L.H.S $\cos (60^\circ + 30^\circ) = \cos 90^\circ = 0$

We know that $\sin 30^\circ = \frac{1}{2}$; $\cos 30^\circ = \frac{\sqrt{3}}{2}$

$$\sin 60^\circ = \frac{\sqrt{3}}{2} \quad \cos 60^\circ = \frac{1}{2}$$

\therefore R.H.S = $\cos 60^\circ \cos 30^\circ - \sin 60^\circ \sin 30^\circ$

$$\frac{1}{2} \times \frac{\sqrt{3}}{2} - \frac{\sqrt{3}}{2} \times \frac{1}{2} = \frac{\sqrt{3}}{4} - \frac{\sqrt{3}}{4} = 0$$

\therefore It is right to say that

$$\cos (60^\circ + 30^\circ) = \cos 60^\circ \cos 30^\circ - \sin 60^\circ \sin 30^\circ.$$

4. In right angled triangle PQR, right angle is at Q and PQ = 6cm, $\angle RPQ = 60^\circ$.

Determine the lengths of QR and PR.

Sol: In ΔPQR $\angle Q = 90^\circ$

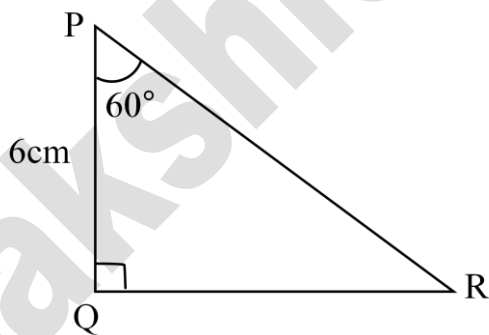

$$PQ = 6\text{cm.}$$

Then $\cos 60^\circ = \frac{\text{Adjacent side}}{\text{Hypotenuse}}$

$$\frac{1}{2} = \frac{PQ}{PR} \quad \left(\because \cos 60^\circ = \frac{1}{2} \right)$$

$$\therefore \frac{PQ}{PR} = \frac{1}{2} \Rightarrow PR = 2PQ = 2 \times 6\text{cm} = 12\text{cm}.$$

Similliarly

$$\sin 60^\circ = \frac{\text{opposite side}}{\text{Hypotenuse}} = \frac{QR}{PR}$$

$$\frac{\sqrt{3}}{2} = \frac{QR}{PR} \Rightarrow QR = \frac{\sqrt{3}.PR}{2}$$

$$\Rightarrow QR = \frac{\sqrt{3}(12)}{2} = 6\sqrt{3}\text{cm}.$$

$$\therefore QR = 6\sqrt{3}\text{cm}, PR = 12\text{cm}.$$

5. In ΔXYZ , right angle is at y , $yz = x$, and $XZ = 2x$ then determine $\angle YXZ$ and $\angle YZX$.

Sol: $\sin X = \frac{\text{opposite side of } \angle X}{\text{hypotenuse}} = \frac{x}{2x} = \frac{1}{2}$

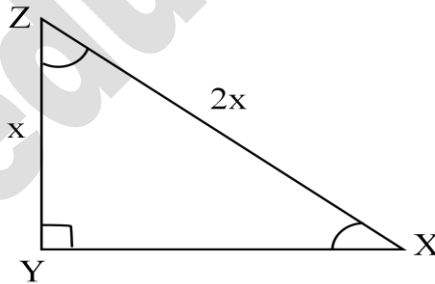

$$\sin X = \frac{1}{2} = \sin 30^\circ$$

$$\Rightarrow X = 30^\circ \text{ or } \angle YXZ = 30^\circ$$

$$\cos Z = \frac{\text{Adjacent side of } \angle Z}{\text{hypotenuse}} = \frac{x}{2x} = \frac{1}{2}$$

$$\cos Z = \frac{1}{2} = \cos 60^\circ$$

$$Z = 60^\circ \text{ or } \angle YZX = 60^\circ$$

Exercise – 11.3

1) Evaluate

(i) $\frac{\tan 36^\circ}{\cot 54^\circ}$ We can write $\tan \theta = \cot (90 - \theta)$.

$$\cot \theta = \tan (90 - \theta)$$

$$\therefore \tan 36^\circ = \cot (90^\circ - 36^\circ)$$

$$\Rightarrow \frac{\tan 36^\circ}{\cot 54^\circ} = \frac{\cot (90^\circ - 36^\circ)}{\cot 54^\circ} = \frac{\cot 54^\circ}{\cot 54^\circ} = 1$$

ii) $\cos 12^\circ - \sin 78^\circ$

$$\Rightarrow \cos (90 - 78^\circ) - \sin 78^\circ \quad (\because \cos(90^\circ - \theta) = \sin \theta)$$

$$\Rightarrow \sin 78^\circ - \sin 78^\circ = 0.$$

iii) $\operatorname{cosec} 31^\circ - \sec 59^\circ$

$$\Rightarrow \operatorname{cosec} (90^\circ - 59^\circ) - \sec 59^\circ$$

$$\Rightarrow \sec 59^\circ - \sec 59^\circ = 0. \quad (\sec \theta = \operatorname{cosec} (90^\circ - \theta))$$

iv) $\sin 15^\circ \sec 75^\circ$

$$\sin 15^\circ \cdot \sec (90 - 15^\circ) \quad (\because \sec(90^\circ - \theta) = \operatorname{cosec} \theta)$$

$$= \sin 15^\circ \cdot \operatorname{Cosec} 15^\circ \quad \left(\because \sin \theta = \frac{1}{\operatorname{cosec} \theta} \right)$$

$$= \sin 15^\circ \cdot \frac{1}{\sin 15^\circ} = 1$$

v) **$\tan 26^\circ \cdot \tan 64^\circ$**

$$\tan 26^\circ \cdot \tan 64^\circ = \tan 26^\circ \cdot \tan (90^\circ - 26^\circ) \quad \left(\begin{array}{l} \because \tan(90^\circ - \theta) = \cot \theta \\ = \cot \theta \cdot \frac{1}{\tan \theta} \end{array} \right)$$

$$= \tan 26^\circ \cdot \cot 26^\circ$$

$$= \tan 26^\circ \cdot \frac{1}{\tan 26^\circ} = 1$$

2. **Show that**

(i) **$\tan 48^\circ \cdot \tan 16^\circ \cdot \tan 42^\circ \cdot \tan 74^\circ = 1$**

(ii) **$\cos 36^\circ \cdot \cos 54^\circ - \sin 36^\circ \cdot \sin 54^\circ = 0$**

A. (i) **$\tan 48^\circ \cdot \tan 16^\circ \cdot \tan 42^\circ \cdot \tan 74^\circ$**

We know that $\tan (90 - \theta) = \cot \theta$.

Re write $\tan 48^\circ = \tan (90^\circ - 42^\circ)$ and $\tan 16^\circ = \tan (90 - 74^\circ)$

$$\Rightarrow \tan 48^\circ \cdot \tan 16^\circ \cdot \tan 42^\circ \cdot \tan 74^\circ$$

$$= \tan (90 - 42^\circ) \cdot \tan (90 - 74^\circ) \cdot \tan 42^\circ \cdot \tan 74^\circ$$

$$= \cot 42^\circ \cdot \cot 74^\circ \cdot \tan 42^\circ \cdot \tan 74^\circ$$

$$= (\cot 42^\circ \cdot \tan 42^\circ) (\cot 74^\circ \cdot \tan 74^\circ)$$

$$= 1 \times 1$$

$$= 1$$

$$\left(\begin{array}{l} \because \cot \theta \cdot \tan \theta = 1 \\ or = \tan \theta \cdot \frac{1}{\cot \theta} \end{array} \right)$$

(ii) $\cos 36^\circ \cdot \cos 54^\circ - \sin 36^\circ \sin 54^\circ = 0.$

A. take L.H.S. $\cos 36^\circ \cdot \cos 54^\circ - \sin 36^\circ \sin 54^\circ$

$$= \cos 36^\circ \cdot \cos (90 - 36^\circ) - \sin 36^\circ (90 - 36^\circ)$$

$$= \cos 36^\circ \cdot \sin 36^\circ - \sin 36^\circ \cdot \cos 36^\circ.$$

$$\left(\begin{array}{l} \because (\cos (90^\circ - \theta) = \sin \theta) \\ \text{Sin } (90^\circ - \theta) = \cos \theta \end{array} \right)$$

$$= 0. \text{ R.H.S.}$$

3. If $\tan 2A = \cot (A - 18^\circ)$, where $2A$ is an acute angle. Find the value of A .

A. Given that $\tan 2A = \cot (A - 18^\circ)$

$$\Rightarrow \cot (90^\circ - 2A) = \cot (A - 18^\circ) \quad (\because \cot(90^\circ - 2A) = \tan 2A)$$

$$\Rightarrow 90^\circ - 2A = A - 18^\circ \quad \left(\begin{array}{l} \because 90^\circ - 2A \text{ and } A - 18^\circ \\ \text{both are acute angles} \end{array} \right)$$

$$\Rightarrow -2A - A = -18 - 90^\circ$$

$$-3A = -108^\circ$$

$$\Rightarrow A = \frac{-108}{-3} = 36^\circ \rightarrow$$

$$A = 36^\circ.$$

4. If $\tan A = \cot B$, where A & B are acute angles, prove that $A + B = 90^\circ$.

Sol: Given that $\tan A = \cot B$.

$$\Rightarrow \tan A = \tan (90^\circ - B) \quad (\because \tan(90^\circ - \theta) = \cot \theta)$$

$$\Rightarrow A = 90^\circ - B \quad \left(\begin{array}{l} \because A \text{ and } (90^\circ - B) \\ \text{both are acute angle.} \end{array} \right)$$

$$\Rightarrow A + B = 90^\circ.$$

5. If A, B and C are interior angle of a triangle ABC, then show that

$$\tan\left(\frac{A+B}{2}\right) = \cot\frac{C}{2}.$$

Sol: The sum of the interior angles in ABC is 180

$$\Rightarrow A + B + C = 180$$

$$\frac{A+B}{2} + \frac{C}{2} = \frac{180^\circ}{2} = 90^\circ$$

$$\Rightarrow \frac{A+B}{2} = 90^\circ - \frac{C}{2}$$

$$\Rightarrow \tan\left(\frac{A+B}{2}\right) = \tan\left(90^\circ - \frac{C}{2}\right) \quad (\because \tan(90^\circ - \theta) = \cot \theta)$$

$$\therefore \tan\left(\frac{A+B}{2}\right) = \cot\frac{C}{2}.$$

6. Express $\sin 75^\circ + \cos 65^\circ$ in terms of trigonometric ratios of angles between 0° and 45° .

A. $\sin 75^\circ = \sin(90^\circ - 15^\circ) = \cos 15^\circ$ ($\because \sin(90^\circ - \theta) = \cos \theta$)

$\cos 65^\circ = \cos(90^\circ - 25^\circ) = \sin 25^\circ.$ ($\because \cos(90^\circ - \theta) = \sin \theta$)

$$\therefore \sin 75^\circ + \cos 65^\circ = \cos 15^\circ + \sin 25^\circ.$$

Exercise – 11.4

1. Evaluating the following.

(i) $(1 + \tan \theta + \sec \theta) (1 + \cot \theta - \operatorname{cosec} \theta)$.A. $(1 + \tan \theta + \sec \theta) (1 + \cot \theta - \operatorname{cosec} \theta)$

$$= (1 + \tan \theta + \sec \theta) \left(1 + \frac{1}{\tan \theta} - \operatorname{cosec} \theta \right)$$

$$= (1 + \tan \theta + \sec \theta) \left(\frac{\tan \theta + 1 - \tan \theta \cdot \operatorname{cosec} \theta}{\tan \theta} \right)$$

$$\left(\frac{(1 + \tan \theta + \sec \theta)(\tan \theta + 1 - \sec \theta)}{\tan \theta} \right) \left(\begin{array}{l} \because \tan \theta \operatorname{cosec} \theta \\ = \frac{\sin \theta}{\cos \theta} \cdot \frac{1}{\sin \theta} \\ \frac{1}{\cos \theta} = \sec \theta \end{array} \right)$$

$$\frac{(1 + \tan \theta)^2 - \sec^2 \theta}{\tan \theta}$$

$$\frac{1 + \tan^2 \theta + 2 \tan \theta - \sec^2 \theta}{\tan \theta}$$

$$\frac{1 + 2 \tan \theta - (\sec^2 \theta - \tan^2 \theta)}{\tan \theta}$$

$$= \frac{1 + 2 \tan \theta - 1}{\tan \theta} = \frac{2 \tan \theta}{\tan \theta} = 2.$$

ii) $(\sin \theta + \cos \theta)^2 + (\sin \theta - \cos \theta)^2$.A. $(\sin \theta + \cos \theta)^2 + (\sin \theta - \cos \theta)^2$

$$\sin^2 \theta + \cos^2 \theta + 2 \sin \theta \cos \theta + \sin^2 \theta + \cos^2 \theta - 2 \sin \theta \cos \theta$$

$$= 2\sin^2 \theta + 2\cos^2 \theta = 2(\sin^2 \theta + \cos^2 \theta) \quad (\because \sin^2 \theta + \cos^2 \theta = 1)$$

$$= 2(1) = 2.$$

iii) $(\sec^2 \theta - 1)(\operatorname{cosec}^2 \theta - 1)$

A. $(\sec^2 \theta - 1)(\operatorname{cosec}^2 \theta - 1)$ $\left(\begin{array}{l} \because \sec^2 \theta - 1 = \tan^2 \theta \\ \operatorname{cosec}^2 \theta - 1 = \cot^2 \theta \end{array} \right)$

$$= \tan^2 \theta \cdot \cot^2 \theta$$

$$= 1.$$

2) **Show that** $(\operatorname{cosec} \theta - \cot \theta)^2 = \frac{1 - \cos \theta}{1 + \cos \theta}$

A. L.H.S $(\operatorname{cosec} \theta - \cot \theta)^2$

$$= \left(\frac{1}{\sin \theta} - \frac{\cos \theta}{\sin \theta} \right)^2 = \left(\frac{1 - \cos \theta}{\sin \theta} \right)^2 = \frac{(1 - \cos \theta)^2}{\sin^2 \theta}$$

$$= \frac{(1 - \cos \theta)^2}{1 - \cos^2 \theta} = \frac{(1 - \cos \theta)^2}{(1 - \cos \theta)(1 + \cos \theta)} = \frac{1 - \cos \theta}{1 + \cos \theta} = R.H.S$$

3) **Show that** $\sqrt{\frac{1 + \sin A}{1 - \sin A}} = \sec A + \tan A.$

A. L.H.S

$$\sqrt{\frac{1 + \sin A}{1 - \sin A}} = \sqrt{\frac{(1 + \sin A)(1 + \sin A)}{(1 - \sin A)(1 + \sin A)}} = \sqrt{\frac{(1 + \sin A)^2}{1 - \sin^2 A}}$$

$$= \sqrt{\frac{(1 + \sin A)^2}{\cos^2 A}} \quad (\because 1 - \sin^2 A = \cos^2 A)$$

$$= \frac{1 + \sin A}{\cos A}$$

$$= \frac{1}{\cos A} + \frac{\sin A}{\cos A}$$

$$= \sec A + \tan A. \text{ R.H.S.}$$

4. **Show that** $\frac{1 - \tan^2 A}{\cot^2 A - 1} = \tan^2 A.$

A. L.H.S

$$\frac{1 - \tan^2 A}{\cot^2 A - 1} = \frac{1 - \frac{\sin^2 A}{\cos^2 A}}{\frac{\cos^2 A}{\sin^2 A} - 1} = \frac{\frac{\cos^2 A - \sin^2 A}{\cos^2 A}}{\frac{\cos^2 A - \sin^2 A}{\sin^2 A}}$$

$$= \frac{\cos^2 A - \sin^2 A}{\cos^2 A} \times \frac{\sin^2 A}{\cos^2 A - \sin^2 A}$$

$$= \frac{\sin^2 A}{\cos^2 A} = \tan^2 A. \quad \text{R.H.S}$$

II Method:

$$\frac{1 - \tan^2 A}{\cot^2 A - 1} = \frac{1 - \tan^2 A}{\frac{1}{\tan^2 A} - 1} = \frac{1 - \tan^2 A}{\frac{1 - \tan^2 A}{\tan^2 A}}$$

$$= \tan^2 A = \text{R.H.S.}$$

5. **Show that** $\frac{1}{\cos \theta} - \cos \theta = \tan \theta \cdot \sin \theta.$

A. L.H.S.

$$\frac{1}{\cos \theta} - \cos \theta = \frac{1 - \cos^2 \theta}{\cos \theta}$$

$$= \frac{\sin^2 \theta}{\cos \theta}$$

$$= \frac{\sin \theta}{\cos \theta} \cdot \sin \theta = \tan \theta \cdot \sin \theta = \text{R.H.S.}$$

∴

$$\text{L.H.S.} = \text{R.H.S.}$$

6. Simplify $\sec A \cdot (1 - \sin A) \cdot (\sec A + \tan A)$.

A. $\sec A (1 - \sin A) \cdot (\sec A + \tan A)$

$$= (\sec A - \sec A \sin A) (\sec A + \tan A)$$

$$= \left(\sec A - \frac{1}{\cos A} \cdot \sin A \right) (\sec A + \tan A) \left(\because \sec A = \frac{1}{\cos A} \right)$$

$$= (\sec A - \tan A) (\sec A + \tan A) \left(\because \tan A = \frac{\sin A}{\cos A} \right)$$

$$= \sec^2 A - \tan^2 A \left(\because \sec^2 A - \tan^2 A = 1 \right)$$

$$= 1.$$

7. Prove that $(\sin A + \operatorname{cosec} A)^2 + (\cos A + \sec A)^2 = 7 + \tan^2 A \cot^2 A$

A. L.H.S $(\sin A + \operatorname{cosec} A)^2 + (\cos A + \sec A)^2$

$$= \sin^2 A + \operatorname{cosec}^2 A + 2 \sin A \cdot \operatorname{cosec} A + \cos^2 A + \sec^2 A + 2 \sec A \cdot \cos A$$

$$= (\sin^2 A + \cos^2 A) + \operatorname{cosec}^2 A + \sec^2 A + 2 \sin A \operatorname{cosec} A + 2 \sec A \cos A$$

$$= 1 + (1 + \cot^2 A) + (1 + \tan^2 A) + 2 \sin A \cdot \frac{1}{\sin A} + 2 \cdot \frac{1}{\cos A} \cdot \cos A$$

$$= 1 + 1 + \cot^2 A + 1 + \tan^2 A + 2 + 2$$

$$= 7 + \cot^2 A + \tan^2 A$$

$$= \text{R.H.S.}$$

8. Simplify $(1 - \cos \theta) (1 + \cos \theta) (1 + \cot^2 \theta)$.

A. $(1 - \cos \theta) (1 + \cos \theta) (1 + \cot^2 \theta)$

$$= (1 - \cos^2 \theta) (1 + \cot^2 \theta) \quad \left(\because 1 + \cot^2 \theta = \operatorname{cosec}^2 \theta \right)$$

$$= \sin^2 \theta (1 + \cot^2 \theta) = \sin^2 \theta \cdot \operatorname{cosec}^2 \theta.$$

$$= 1.$$

9. If $\sec \theta + \tan \theta = P$; then what is the value of $\sec \theta - \tan \theta$?

A. $\sec \theta + \tan \theta = P$. (Given)

We know that $\sec^2 \theta - \tan^2 \theta = 1$ $(a^2 - b^2 = (a+b)(a-b))$

$$\Rightarrow (\sec \theta + \tan \theta) (\sec \theta - \tan \theta) = 1$$

$$P (\sec \theta - \tan \theta) = 1$$

$$\Rightarrow \sec \theta - \tan \theta = \frac{1}{P}$$

$$\therefore \text{The value of } \sec \theta - \tan \theta = \frac{1}{P}.$$

10. If $\operatorname{cosec} \theta + \cot \theta = k$, then show that $\cos \theta = \frac{k^2 - 1}{k^2 + 1}$.

A. Given that $\operatorname{cosec} \theta + \cot \theta = k \rightarrow (1)$

Then $\operatorname{cosec} \theta - \cot \theta = \frac{1}{k} \rightarrow (2)$

$$\left[\begin{array}{l} \because \operatorname{cosec}^2 \theta - \cot^2 \theta = 1 \\ (\operatorname{cosec} \theta + \cot \theta) \\ (\operatorname{cosec} \theta - \cot \theta) = 1 \\ \operatorname{cosec} \theta - \cot \theta = \frac{1}{\operatorname{cosec} \theta + \cot \theta} \end{array} \right]$$

Adding (1) & (2) we get

$$2 \cos \theta = k + \frac{1}{k} \Rightarrow 2 \cos \theta = \frac{k^2 + 1}{k} \rightarrow (3)$$

Subtracting (2) from (1) we get

$$2 \cot \theta = k - \frac{1}{k} \Rightarrow 2 \cot \theta = \frac{k^2 - 1}{k} \rightarrow (4)$$

Dividing (4) by (3) we get

$$\frac{2 \cot \theta}{2 \cos \theta} = \frac{\frac{k^2 - 1}{k}}{\frac{k^2 + 1}{k}} = \frac{k^2 - 1}{k} \times \frac{k}{k^2 + 1}$$

$$\frac{\cos \theta}{\sin \theta} \cdot \sin \theta = \frac{k^2 - 1}{k^2 + 1}$$

$$\therefore \cos \theta = \frac{k^2 - 1}{k^2 + 1}$$

Objective Type Questions

1. In the following figure, the value of $\cot A$ is []

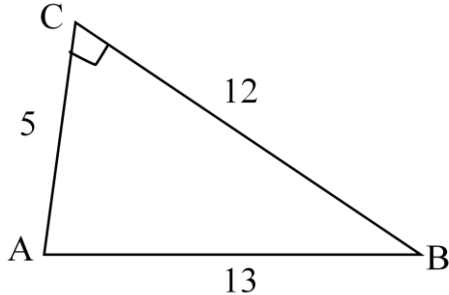

- a) $\frac{12}{13}$ b) $\frac{5}{12}$ c) $\frac{5}{13}$ d) $\frac{13}{5}$

2. If in $\triangle ABC$, $\angle B = 90^\circ$, $AB = 12$ cm and $BC = 5$ cm then the value of $\cos c$ is.

[]

- a) $\frac{5}{13}$ b) $\frac{5}{12}$ c) $\frac{12}{5}$ d) $\frac{13}{5}$

3. If $\cot \theta = \frac{b}{a}$ then the value of $\frac{\cos \theta + \sin \theta}{\cos \theta - \sin \theta}$ is []

- a) $\frac{b-a}{b+a}$ b) $b-a$ c) $b+a$ d) $\frac{b+a}{b-a}$

4. The maximum value of $\sin \theta$ is _____ []

- a) $\frac{1}{2}$ b) $\frac{\sqrt{3}}{2}$ c) 1 d) $\frac{1}{\sqrt{2}}$

5. If A is an acute angle of a $\triangle ABC$, right angled at B, then the value of $\sin A + \cos A$ is []

- a) Equal to one b) greater than two
c) Less than one d) equal to two

6. The value of $\frac{2 \tan 30^\circ}{1 + \tan^2 30^\circ}$ is []
- a) $\sin 60^\circ$ b) $\cos 60^\circ$ c) $\tan 60^\circ$ d) $\sin 30^\circ$
7. If $\sin \theta = \frac{1}{2}$, then the value of $(\tan \theta + \cot \theta)^2$ is []
- a) $\frac{16}{3}$ b) $\frac{8}{3}$ c) $\frac{4}{3}$ d) $\frac{10}{3}$
8. If $\sin \theta - \cos \theta = 0$; then the value of $\sin^4 \theta + \cos^4 \theta$ is []
- a) $\frac{1}{2}$ b) $\frac{1}{4}$ c) $\frac{3}{4}$ d) 1
9. If $\theta = 45^\circ$ then the value of $\frac{1 - \cos 2\theta}{\sin 2\theta}$ is []
- a) 0 b) 1 c) 2 d) ∞
10. If $\tan \theta = \cot \theta$, then the value of $\sec \theta$ is []
- a) 2 b) 1 c) $\frac{1}{\sqrt{3}}$ d) $\sqrt{2}$
11. If $A + B = 90^\circ$, $\cot B = \frac{3}{4}$ then $\tan A$ is equal to []
- a) $\frac{5}{3}$ b) $\frac{1}{3}$ c) $\frac{3}{4}$ d) $\frac{1}{4}$
12. If $\sin (x - 20^\circ) = \cos (3x - 10)^\circ$. Then x is []
- a) 60° b) 30° c) 45° d) 35.5
13. The value of $1 + \tan 5^\circ \cot 85^\circ$ is equal to []
- a) $\sin^2 5^\circ$ b) $\cos^2 5^\circ$ c) $\sec^2 5^\circ$ d) $\operatorname{cosec}^2 5^\circ$

14. If any triangle ABC, the value of $\sin \frac{B+C}{2}$ is _____ []
- a) $\cos \frac{A}{2}$ b) $\sin \frac{A}{2}$ c) $-\sin \frac{A}{2}$ d) $-\cos \frac{A}{2}$
15. If $\cos \theta = \frac{a}{b}$, then cosec θ is equal to []
- a) $\frac{b}{a}$ b) $\frac{b}{\sqrt{b^2 - a^2}}$ c) $\frac{\sqrt{b^2 - a^2}}{b}$ d) $\frac{a}{\sqrt{b^2 - a^2}}$
16. The value of $\cos 20^\circ \cos 70^\circ - \sin 20^\circ \sin 70^\circ$ is equal to []
- a) 0 b) 1 c) ∞ d) $\cos 50^\circ$
17. The value of $\tan 5^\circ \tan 25^\circ \tan 45^\circ \tan 65^\circ \tan 85^\circ$ is _____ []
- a) 2 b) 3 c) 1 d) 4
18. If $\tan \theta + \cot \theta = 5$ then the value of $\tan^2 \theta + \cot^2 \theta$ is _____ []
- a) 23 b) 25 c) 27 d) 15
19. If $\operatorname{cosec} \theta = 2$ and $\cot \theta = \sqrt{3} p$ where θ is an acute angle, then the value of p is []
- a) 2 b) 1 c) 0 d) $\sqrt{3}$
20. $\frac{\sqrt{1 + \sin A}}{\sqrt{1 - \sin A}}$ is equal to []
- a) $\sin A + \cos A$ b) $\sec A + \tan A$
 c) $\sec A - \tan A$ d) $\sec^2 A + \tan^2 A$

Key:

1. b; 2. a; 3. d; 4. c; 5. b; 6. a; 7. a; 8. a; 9. b; 10. d;
 11. c; 12. b; 13. c; 14. a; 15. c; 16. b; 17. c; 18. a; 19. b; 20. b.

Fill in the Blanks

1. If $\operatorname{cosec}\theta - \cot\theta = \frac{1}{4}$ then the value of $\operatorname{cosec}\theta + \cot\theta$ is _____
2. $\sin 45^\circ + \cos 45^\circ =$ _____
3. $2 \tan^2 45^\circ + \cos^2 30^\circ - \sin^2 60^\circ =$ _____
4. $\sin (90^\circ - A) =$ _____
5. If $\sin A = \cos B$ then, the value of $A + B =$ _____
6. If $\sec\theta = \frac{m+n}{2\sqrt{mn}}$ then $\sin\theta =$ _____
7. In the adjacent figure, the value of $\sec A$ is _____.

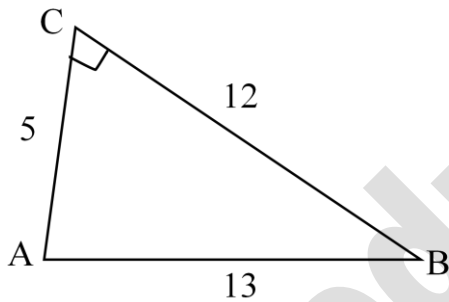

8. If $\sin A = \frac{1}{2} \tan^2 45^\circ$, where A is an acute angle then the value of A is _____
9. The maximum value of $\frac{1}{\sec\theta}$, $0^\circ < \theta < 90^\circ$ is _____
10. $\frac{\sin^2 \theta}{1 - \cos^2 \theta}$ is equal to _____
11. if $\cot\theta = 1$ then $\frac{1 + \sin\theta}{\cos\theta} =$ _____
12. $\sec^2\theta - 1 =$ _____
13. If $\sec\theta + \tan\theta = p$, then the value of $\sec\theta - \tan\theta =$ _____.

14. The value of $\sin A$ or $\cos A$ never exceeds _____.

15. $\sec(90^\circ - A) =$ _____

Key:

- 1) 4; 2) $\sqrt{2}$; 3) 2; 4) $\cos A$; 5) 90° ; 6) $\frac{m-n}{m+n}$;
- 7) $\frac{13}{5}$; 8) 15° ; 9) 1; 10) 1; 11) $\sqrt{2} + 1$; 12) $\tan^2 \theta$;
- 13) $\frac{1}{p}$; 14) 1; 15) $\operatorname{cosec} A$.

Trigonometric Identities

An identity equation having trigonometric ratios of an angle is called trigonometric identity. And it is true for all the values of the angles involved in it.

(1) $\sin^2 A + \cos^2 A = 1$

$$\sin^2 A = 1 - \cos^2 A, \cos^2 A = 1 - \sin^2 A$$

$$\sin A = \sqrt{1 - \cos^2 A} = \sqrt{(1 + \cos A)(1 - \cos A)}$$

$$\cos A = \sqrt{1 - \sin^2 A} = \sqrt{(1 + \sin A)(1 - \sin A)}$$

(2) $1 + \tan^2 A = \sec^2 A$ or $\sec^2 A - 1 = \tan^2 A$

$$\sec^2 A - \tan^2 A = 1 \quad \text{or} \quad \tan^2 A - \sec^2 A = -1$$

$$(\sec A + \tan A)(\sec A - \tan A) = 1$$

$$\sec A + \tan A = \frac{1}{\sec A - \tan A} \quad (\text{or}) \quad \sec A - \tan A = \frac{1}{\sec A + \tan A}$$

$$(3) \quad 1 + \cot^2 A = \operatorname{cosec}^2 A \text{ (or) } \operatorname{cosec}^2 A - 1 = \cot^2 A$$

$$\operatorname{Cosec}^2 A - \cot^2 A = 1 \text{ (or) } \cot^2 A - \operatorname{cosec}^2 A = -1$$

$$(\operatorname{cosec} A + \cot A) (\operatorname{cosec} A - \cot A) = 1$$

$$\operatorname{cosec} A + \cot A = \frac{1}{\operatorname{cosec} A - \cot A} \text{ (or) } \operatorname{cosec} A - \cot A = \frac{1}{\operatorname{cosec} A + \cot A}$$

$$(\sin \theta + \cos \theta)^2 + (\sin \theta - \cos \theta)^2 = 2$$

$$(\sec^2 \theta - 1) (\operatorname{cosec}^2 \theta - 1) = 1.$$

Sakshieducation.com

Applications of Trigonometry

The height or length of an object or the distance between two distant objects can be determined with the help of trigonometric ratios.

- **The Line of sight** is the line drawn from the eye of an observer to the point in the object viewed by the observer.
- **The angle of elevation** of an object viewed is the angle formed by the line of sight with the horizontal when it is above the horizontal level i.e. the case when we raise our head to look at the object.
- **The angle of depression** of an object viewed is the angle formed by the line of sight with the horizontal when it is below the horizontal level i.e. the case when lower our head to look at the object.

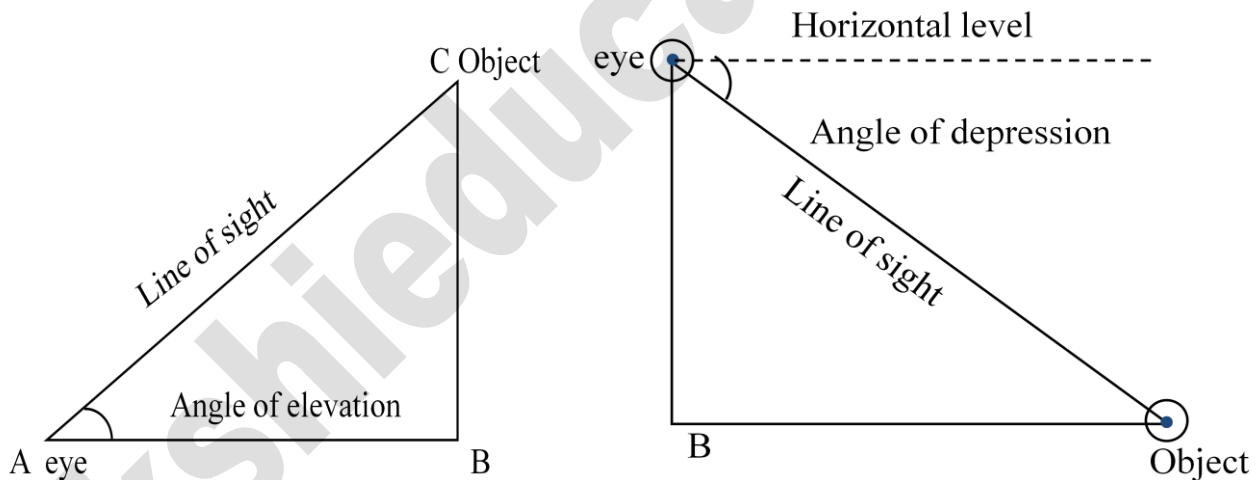

- Trigonometry has been used by surveyors for centuries. They use **Theodolites** to measure angles of elevation or depression in the process of survey.
- When we want to solve the problems of heights and distances, we should consider the following.
 - i) All the objects such as tower, trees, buildings, ships, mountains etc. Shall be considered as linear for mathematical convenience

- ii) The angle of elevation or angle of depression is considered with reference to the horizontal line.
- iii) The height of the observer is neglected, if it is not given in the problem.

- The angle of elevation of a tower from a distance 'd' m from its foot is α° and height of the tower is 'h' m then

$$\tan \alpha = \frac{h}{d}$$

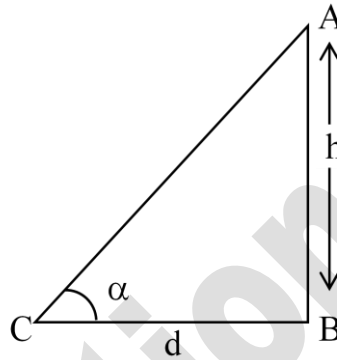

- The angle of elevation of the top of a tower as observed from a point on the ground is ' α ' and on moving 'd' meters towards the tower, the angle of elevation is ' β ', then the height of the tower $h = \frac{d}{\cot \alpha - \cot \beta}$

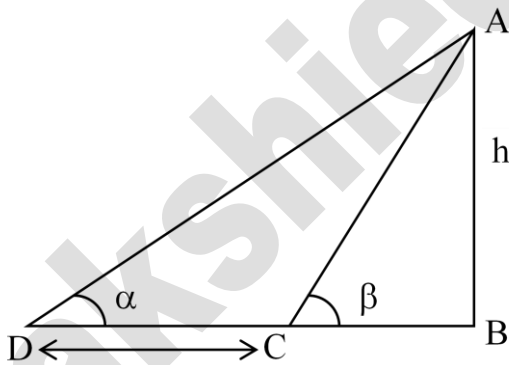

- Two men on either side of the tower and in the same straight line with its base notice the angle of elevation of top of the tower to be α and β . If the height of the tower is 'h' m, then the distance between the two men $d = \frac{h \sin(\alpha + \beta)}{\sin \alpha \cdot \sin \beta}$

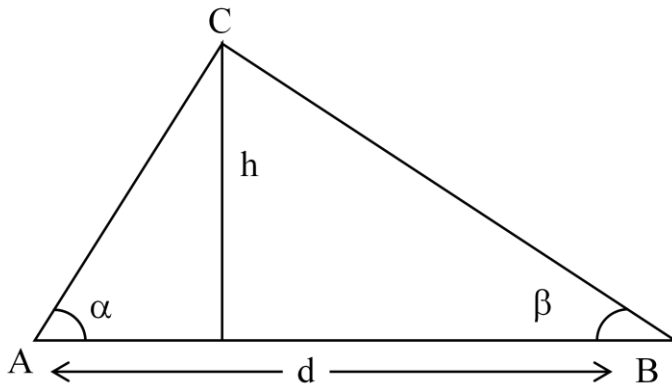

- A statue 'd' m tall stands on the top of a pedestal which is the height of 'h' m. From a point on the ground, the angle of elevation of the top of the statue is α and from the same point the angle of elevation of the top of the pedestal is β , then the height of the statue is

$$d = \frac{h(\cot \alpha - \cot \beta)}{\cot \beta}$$

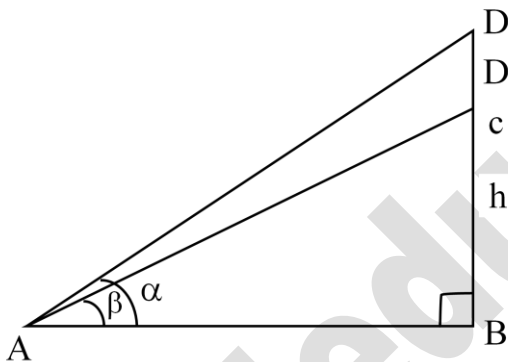

- Two poles of equal height are standing opposite each other on either side of the road, which is x m wide. From a point between them on the road, the of the poles are α and β

respectively, then the height of the pole $h = \frac{x \tan \alpha \cdot \tan \beta}{\tan \alpha + \tan \beta}$

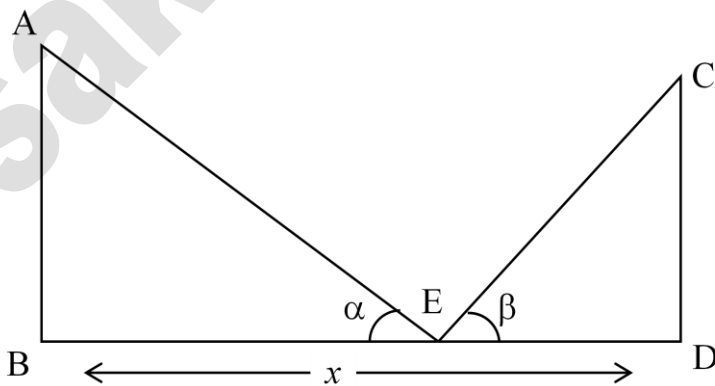

$$\text{And the length of BE} = \frac{x \tan \beta}{\tan \alpha + \tan \beta}$$

$$\text{The length of DE} = \frac{x \tan \alpha}{\tan \alpha + \tan \beta}$$

Exercise 12.1

1. A tower stands vertically on the ground. From a point which is 15 meter away from the foot of the tower, the angle of elevation of the top of the tower is 45° . What is the height of the tower?

Sol: Let the height of the tower = AB

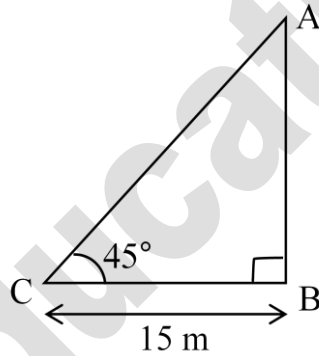

Distance between foot of the tower and observation point 'C' is $BC = 15$ mts.

Angle of elevation of the top of tower $\angle C = 45^\circ$

$$\text{Form } \Delta ABC, \tan C = \frac{AB}{BC}$$

$$\tan 45^\circ = \frac{AB}{BC}$$

$$\Rightarrow 1 = \frac{AB}{15}$$

$$\Rightarrow AB = 15 \text{ mts.}$$

\therefore Height of the tower $AB = 15$ m.

2. A tree breaks due to storm and the broken part bends so that the top of the tree touches the ground by making 30° angle with the ground. The distance between the foot of the tree and the top of the tree on the ground is 6m. Find the height of the tree before falling down.

Sol: In right triangle ABC,

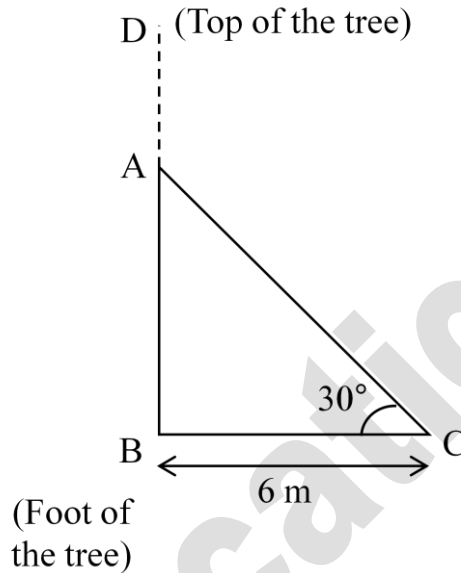

$$\cos 30^\circ = \frac{BC}{AC}$$

$$\Rightarrow \frac{\sqrt{3}}{2} = \frac{6}{AC}$$

$$\Rightarrow AC = \frac{12}{\sqrt{3}} m.$$

$$\text{Ily } \tan 30^\circ = \frac{AB}{BC}$$

$$\Rightarrow \frac{1}{\sqrt{3}} = \frac{AB}{6} \Rightarrow AB = \frac{6}{\sqrt{3}} m.$$

\therefore Height of the tree = AB + AC

$$= \left(\frac{12}{\sqrt{3}} + \frac{6}{\sqrt{3}} \right) m$$
$$= \frac{18}{\sqrt{3}} m = 6\sqrt{3}$$

∴ The height of the tree before falling down is = $6\sqrt{3}m$.

3. A contractor wants to set up a slide for the children to play in the park, He wants to set it up at the height of 2m and by making an angle of 30° with the ground. What should be the length of the slide

Sol: height of the slide = 2m

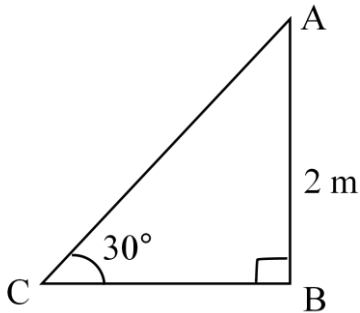

Length of the slide = ?

In right triangle ABC

$$\sin 30^\circ = \frac{AB}{AC}$$

$$\Rightarrow \frac{1}{2} = \frac{2}{AC}$$

∴ The length of the slide AC = 4m.

4.Length of the shadow of a 15 meter high pole is $5\sqrt{3}$ meters at 7 'o' clock in the morning. Then, what is the angle of elevation of the sun rays with the ground at the time?

Sol: Height of the pole $AB = 15\text{m}$

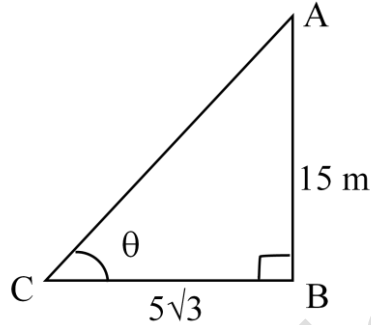

Length of the shadow of the pole $BC = 5\sqrt{3}\text{m}$

Let the angle of elevation of sunrays with ground is $\angle ACB = \theta$ say.

From right triangle ABC,

$$\tan \theta = \frac{AB}{BC} = \frac{15}{5\sqrt{3}} = \frac{3}{\sqrt{3}} = \sqrt{3}$$

$$\Rightarrow \tan \theta = \sqrt{3}$$

$$(\because \tan 60^\circ = \sqrt{3})$$

$$\Rightarrow \tan \theta = \tan 60^\circ$$

$$\therefore \theta = 60^\circ$$

$$\therefore \angle ACB = 60^\circ$$

\therefore The angle of elevation = 60° .

5. You want to erect a pole of height 10m with the support of three ropes. Each rope has to make an angle 30° with the pole. What should be the length of the rope?

Sol: Height of the pole $AB = 10\text{m}$

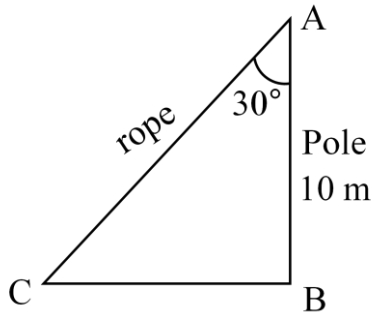

Let the length of rope to erect the pole = AC

Angle made by the rope with the pole = 30°

From right triangle $\cos A = \frac{AB}{AC}$

$$\Rightarrow \cos 30^\circ = \frac{10}{AC}$$

$$\Rightarrow \frac{\sqrt{3}}{2} = \frac{10}{AC}$$

$$\Rightarrow AC = \frac{20}{\sqrt{3}} \times \frac{\sqrt{3}}{\sqrt{3}} = \frac{20\sqrt{3}}{3} = \frac{20 \times 1.732}{3}$$

$$\Rightarrow AC = 11.55\text{m}$$

\therefore Length of the rope = 11.55m.

6. Suppose you are shooting an arrow from the top of a building at a height of 6m to a target on the ground at an angle of depression of 60° . What is the distance between you and the object.

Sol: Height of a building $AB = 6\text{m}$

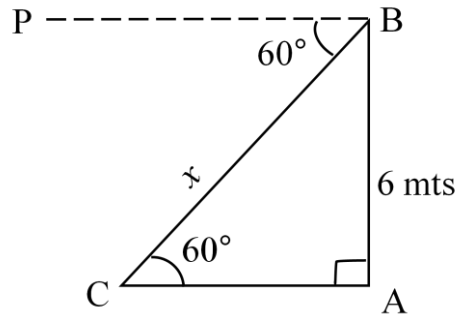

Angle of depression from top of a building 'B' to a target 'C' is 60°

$$\angle PBC = \angle BCA = 60^\circ \quad (\because PB \parallel AC, \text{ they are alternate angles})$$

The distance between me and the object $BC = x$ say.

From right triangle ABC

$$\sin 60^\circ = \frac{AB}{BC}$$

$$\Rightarrow \frac{\sqrt{3}}{2} = \frac{6}{BC}$$

$$\Rightarrow BC = \frac{12}{\sqrt{3}} = \frac{12\sqrt{3}}{\sqrt{3} \cdot \sqrt{3}} = \frac{12\sqrt{3}}{3}$$

$$= 4\sqrt{3}\text{m}$$

\therefore The distance between me and the object is $4\sqrt{3}\text{m}$.

7. An electrician wants to repair an electric connection on a pole of height 9m. He needs to reach 1.8m below the top of the pole to do repair works. What should be the length of the ladder which he should use, when he climbs it at an angle of 60° with the ground? What will be the distance between foot of the ladder and foot of the pole?

Sol: Height of electric pole $AB = 9\text{m}$.

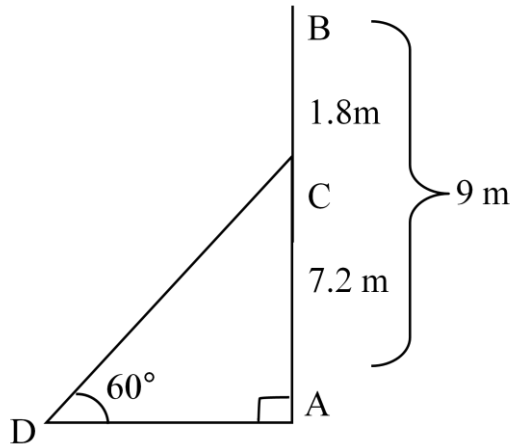

Length of a ladder = CD say.

Height of electric pole to do repair work $AC = AB - BC$

$$= 9 - 1.8 = 7.2$$

Distance between foot of ladder and the pole = AD

Angle made by ladder with ground at D = 60°

\therefore from right triangle ACD

$$\sin 60^\circ = \frac{AC}{CD}$$

$$\frac{\sqrt{3}}{2} = \frac{7.2}{CD}$$

$$\Rightarrow CD = \frac{7.2 \times 2}{\sqrt{3}} = \frac{14.4}{\sqrt{3}} \times \frac{\sqrt{3}}{\sqrt{3}}$$

$$= \frac{14.4 \times \sqrt{3}}{3} = 4.8 \times 1.732$$

$$= 8.3136 \text{ m.}$$

$$\text{Ily } \tan 60^\circ = \frac{AC}{AD}$$

$$\sqrt{3} = \frac{7.2}{AD}$$

$$\Rightarrow AD = \frac{7.2}{\sqrt{3}} \times \frac{\sqrt{3}}{\sqrt{3}} = \frac{7.2 \times 1.732}{3}$$

$$= 2.4 \times 1.732$$

$$= 4.1568 \text{ m.}$$

\therefore The distance between foot of the ladder and foot of the pole = 4.1568m.

- 8. A boat has to cross a river. It crosses the river by making an angle of 60° with the bank of the river due to the stream of the river and travels a distance of 600 m to reach the another side of the river. What is the width of the river?**

Sol: Let the width of a river is AB.

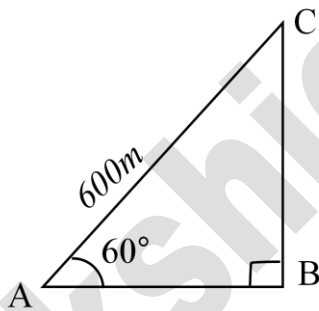

Making angle with the bank of river $\angle CAB = 60^\circ$

Travel of boat from A to C, $AC = 600 \text{ m.}$

From right triangle ABC

$$\cos 60^\circ = \frac{AB}{AC}$$

$$\Rightarrow \frac{1}{2} = \frac{AB}{600}$$

$$\Rightarrow AB = \frac{600}{2} = 300m.$$

\therefore The width of the river = 300m.

- 9. An observer of height 1.8m is 13.2 m away from a palm tree. The angle of elevation of the top of the tree from his eyes is 45° . What is the height of the palm tree?**

Sol: Height of the observer AB = 1.8m.

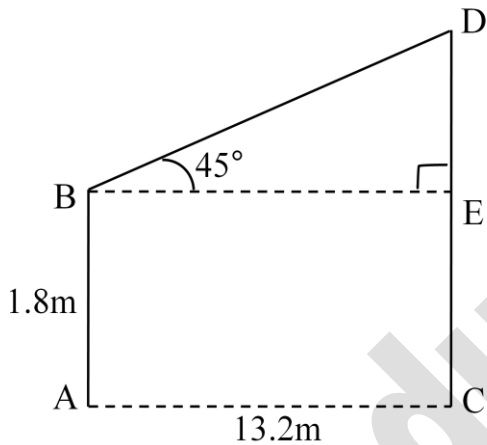

Height of the palm tree = CD say.

Distance between the palm tree and observer

AC is 13.2m.

From figure we observed that AC = BE and

AB = CE = 1.8m.

\therefore From right triangle ΔDBE , we get

$$\tan 45^\circ = \frac{DE}{BE}$$

$$\Rightarrow 1 = \frac{DE}{AC} \quad (\because BE = AC = 13.2m)$$

$$\Rightarrow 1 = \frac{DE}{13.2}$$

$$\Rightarrow DE = 13.2\text{m}$$

Length of the palm tree $CD = CE + ED$

$$= 1.8 + 13.2$$

$$= 15\text{m.}$$

10. in the adjacent figure $AC = 6\text{ cm}$, $AB = 5\text{cm}$ and $\angle BAC = 30^\circ$. Find the area of the triangle?

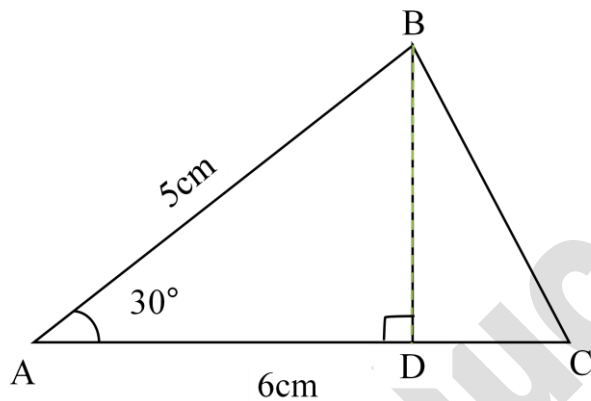

Sol: From the triangle we get $\sin 30^\circ = \frac{BD}{AB} = \frac{BD}{5}$

$$\Rightarrow \frac{1}{2} = \frac{BD}{5} \Rightarrow BD = \frac{5}{2} = 2.5\text{cm.}$$

$$\therefore \text{Area of } \Delta ABC = \frac{1}{2} \times AC \times BD$$

$$= \frac{1}{2} \times 6 \times 2.5 = 7.5\text{cm}^2$$

$$\therefore \text{Area of } \Delta ABC = 7.5 \text{ sq.cm.}$$

11. A TV tower stands vertically on the side of a road. From a point on the other side directly opposite to the tower, the angle of elevation of the top of tower is 60° . From another point 10m away from this point, on the tower, the angle of elevation of the top of the tower is 30° . Find the height of the tower and the width of the road?

Sol: Height of the tower is AB say

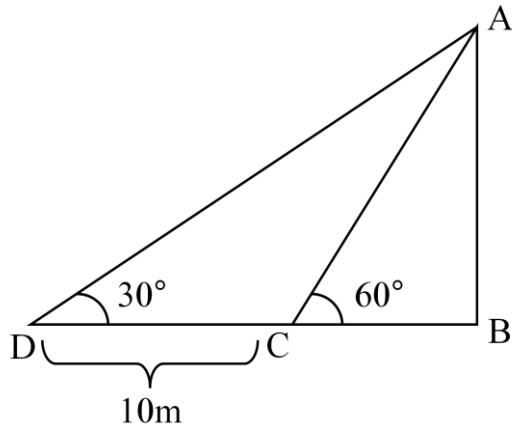

Width of the road is BD say

Distance between two observation points C and D is $CD = 10\text{m}$.

From right triangle ΔABC we get

$$\tan 60^\circ = \frac{AB}{BC} \Rightarrow AB = BC\sqrt{3} \longrightarrow (1)$$

lly in ΔABD , $\tan 30^\circ = \frac{AB}{BD}$

$$\frac{1}{\sqrt{3}} = \frac{AB}{BC + CD}$$

$$\Rightarrow AB = \frac{BC + CD}{\sqrt{3}} \longrightarrow (2)$$

From (1) & (2), we get

$$\sqrt{3}.BC = \frac{BC + CD}{\sqrt{3}}$$

$$\Rightarrow 3 BC = BC + CD$$

$$\Rightarrow 3 BC - BC = CD$$

$$\Rightarrow 2 BC = CD$$

$$BC = \frac{CD}{2}$$

$$BC = \frac{10}{2} = 5 \quad (\because \text{we know that } CD = 10\text{m})$$

$$\begin{aligned} \therefore \text{width of the road } BD &= BC + CD \\ &= 5 + 10 = 15\text{m.} \end{aligned}$$

$$\begin{aligned} \text{Height of the tower } AB &= \sqrt{3} \cdot BC \\ &= \sqrt{3} \cdot 5 = 5\sqrt{3}\text{m.} \end{aligned}$$

12. A 1.5m tall boy is looking at the top of a temple which is 30 meter in height from a point at certain distance. The angle of elevation from his eye to the top of the crown of the temple increases from 30° to 60° as he walks towards the temple. Find the distance he walked towards the temple.

Sol: height of the temple $AB = 30\text{m}$.

Height of the Boy $PR = 1.5\text{m}$.

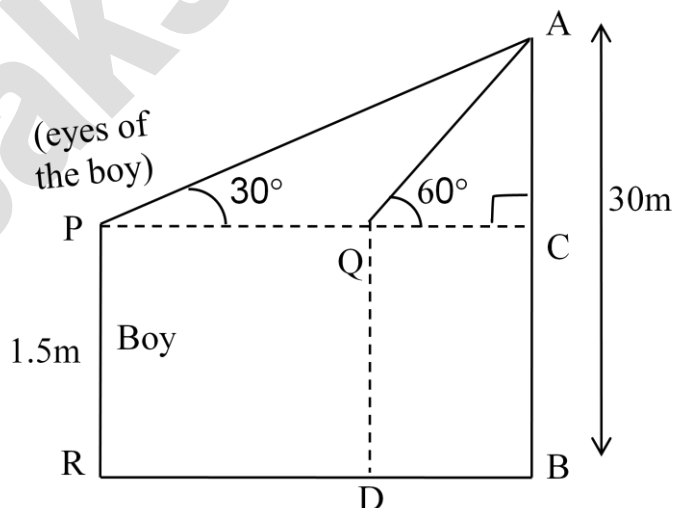

The angle of elevation from his eye to the top of the temple is $\angle APC = 30^\circ$.

From figure we observed $AC = AB - BC$

$$= AB - PR \quad (\because BC = PR)$$

$$= 30 - 1.5$$

$$AC = 28.5\text{m}$$

In right triangle ACQ, we get

$$\tan 60^\circ = \frac{AC}{QC} = \frac{28.5}{QC}$$

$$\Rightarrow \sqrt{3} = \frac{28.5}{QC}$$

$$\Rightarrow QC = \frac{28.5}{\sqrt{3}} \times \frac{\sqrt{3}}{\sqrt{3}} = \frac{28.5 \times \sqrt{3}}{3}$$

$$\therefore QC = 9.5\sqrt{3}.$$

In right triangle APC, we get

$$\tan 30^\circ = \frac{AC}{PC} = \frac{28.5}{PC}$$

$$\Rightarrow \frac{1}{\sqrt{3}} = \frac{28.5}{PC}$$

$$\Rightarrow PC = 28.5\sqrt{3}.$$

\therefore The distance walked towards the temple is PQ

$$\therefore PQ = PC - QC$$

$$= 28.5\sqrt{3} - 9.5\sqrt{3}$$

$$= (28.5 - 9.5) \times \sqrt{3}$$

$$= 19 \times 1.732$$

$$= 32.908\text{m.}$$

- 13. A statue stands on the top of a 2m tall pedestal. From a point on the ground, the angle of elevation of the top of the statue is 60° and from the same point, the angle of elevation of the top of pedestal is 45° . Find the height of the statue.**

Sol: Let the height of the statue $AB = h$ say.

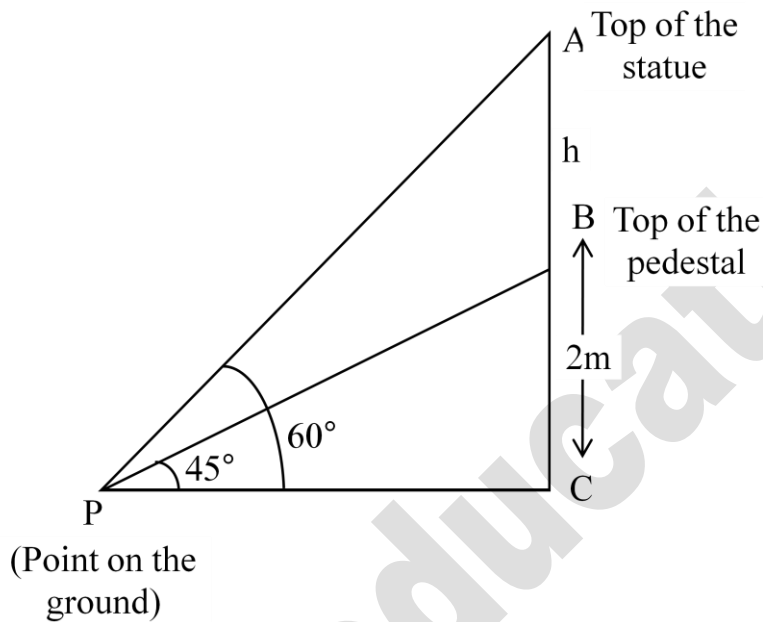

Height of the pedestal $BC = 2\text{m}$

In right triangle BCP , we get

$$\tan 45^\circ = \frac{BC}{PC} \quad (\text{point on the ground})$$

$$\Rightarrow 1 = \frac{BC}{PC} \Rightarrow PC = 2\text{m} \longrightarrow (1)$$

lly in right triangle ACP , we get

$$\tan 60^\circ = \frac{AC}{PC}$$

$$\Rightarrow \sqrt{3} = \frac{AC}{2} \Rightarrow AC = 2\sqrt{3}.$$

∴ The height of the statue $AB = AC - BC$

$$= 2\sqrt{3} - 2$$

$$= 2(\sqrt{3} - 1)$$

$$= 2(1.732 - 1)$$

$$= 2 \times 0.732$$

$$= 1.464\text{m.}$$

14. From the top of a Building, the angle of elevation of the top of a cell tower is 60° and the angle of depression to its foot is 45° . If distance of the building from the tower is 7m then find the height of the tower.

Sol: Height of the building $AB = h$ say.

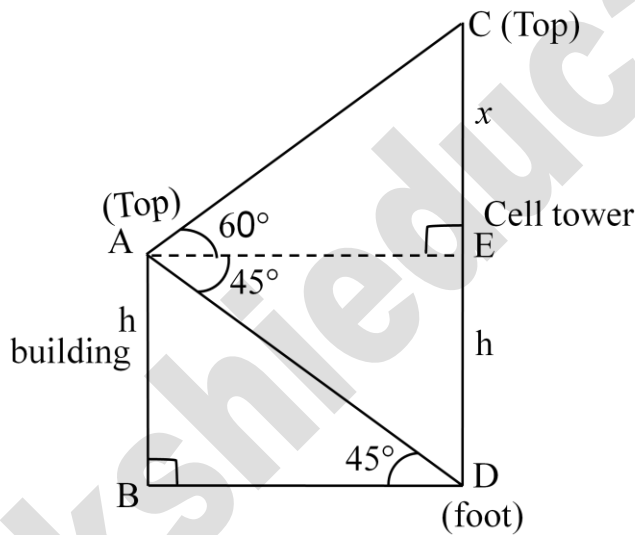

Let $AB = DE = h$

$CE = x$ say.

The distance between the tower and building $BD = 7\text{m}$.

From the figure $BD = AE = 7\text{m}$.

From right triangle ACE $\tan 60^\circ = \frac{CE}{AE}$

$$\sqrt{3} = \frac{CE}{7} \Rightarrow CE = 7\sqrt{3}$$

$$x = 7\sqrt{3}m.$$

From right triangle ABD, we get

$$\tan 45^\circ = \frac{AB}{BD}$$

$$1 = \frac{AB}{7} = \frac{h}{7}$$

$\therefore h = 7m.$ and $AB = ED = 7m.$

\therefore The height of cell tower $CD = CE + ED$

$$= 7\sqrt{3} + 7$$

$$= 7(\sqrt{3} + 1)$$

$$= 7(1.732 + 1)$$

$$= 7(2.732)$$

$$= 19.124m.$$

- 15. A wire of length 18m had been tied with electric pole at an angle of elevation 30° with the ground. Because it was conversing a long distance, it was cut and tied at an angle of elevation 60° with ground. How much length of the wire was cut?**

Sol: Height of electric pole = $AB = h$ say.

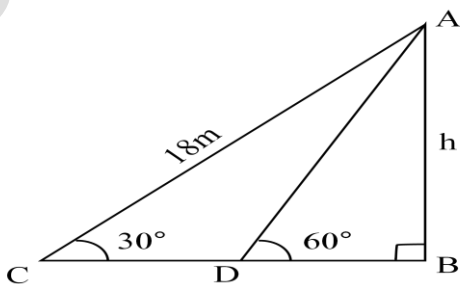

Length of a wire = AC = 18m.

From figure

In right triangle ACB, we get

$$\sin 30^\circ = \frac{AB}{AC} = \frac{h}{18}$$

$$\Rightarrow \frac{1}{2} = \frac{h}{18} \Rightarrow h = \frac{18}{2} = 9m \longrightarrow (1)$$

lly from triangle ADB, we get

$$\sin 60^\circ = \frac{AB}{AD} = \frac{h}{AD}$$

From (1) $h = 9m$

$$\Rightarrow \frac{\sqrt{3}}{2} = \frac{9}{AD}$$

$$\Rightarrow AD = \frac{18}{\sqrt{3}} = \frac{18}{\sqrt{3}} \times \frac{\sqrt{3}}{\sqrt{3}} = \frac{18\sqrt{3}}{3} = 6\sqrt{3}m.$$

\therefore The length of the remaining wire after cutting

$$= 18 - 6\sqrt{3} = (18 - 6 \times 1.732)$$

$$= 18 - 10.392$$

$$= 7.608m.$$

16. The angle of elevation of the top of a building from the foot of the tower is 30° and the angle of elevation of the top of the tower from the foot of the building is 60° . If the tower is 30m high, find the height of the building.

Sol: Let the height of the building be $AB = h$ m
 The height of the tower $PQ = 30$ m.

From figure in right triangle ΔPBQ

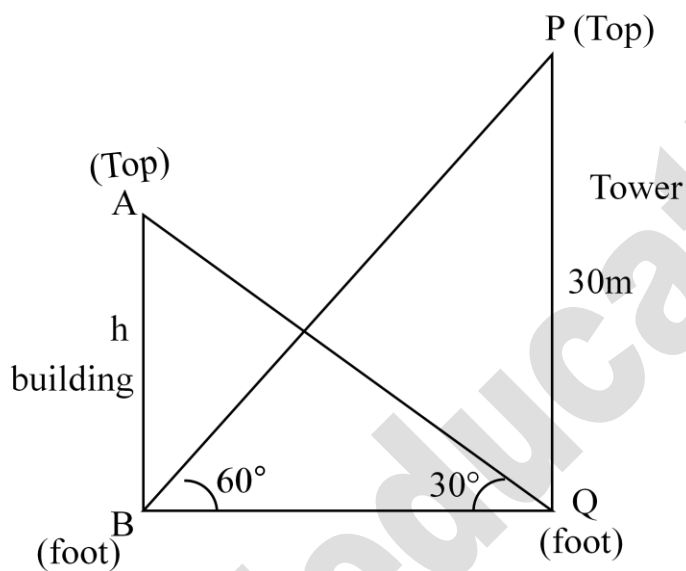

We get $\tan 60^\circ = \frac{PQ}{BQ}$

$$\sqrt{3} = \frac{30m}{BQ}$$

$$\Rightarrow BQ = \frac{30}{\sqrt{3}} m \rightarrow (1)$$

In right triangle ΔAQB , we get

$$\tan 30 = \frac{AB}{BQ} = \frac{h}{BQ}$$

$$\Rightarrow \frac{1}{\sqrt{3}} = \frac{h}{BQ}$$

$$\Rightarrow BQ = h\sqrt{3} \longrightarrow (2)$$

From (1) & (2) we get

$$h\sqrt{3} = \frac{30}{\sqrt{3}}$$

$$h = \frac{30}{\sqrt{3} \times \sqrt{3}} = \frac{30}{3} = 10m.$$

∴ The height of the Building is 10m.

- 17. Two poles of equal heights are standing opposite to each other on either side of the road. Which is 120 feet wide from a point between them on the road, the angles of elevation of the top of the poles are 60° and 30° respectively. Find the height of the poles and the distances of the point from the poles.**

Sol: The two poles of equal heights are AB and PQ say. Where $AB = PQ = H$ say.

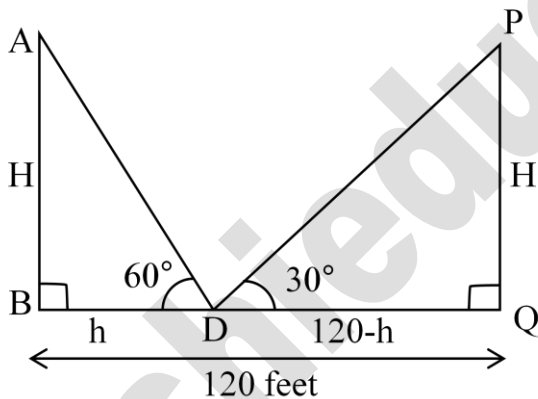

The distance between the two poles AB and PQ is 120 feet.

Take 'D' is a point between them and let $BD = h$ m

From figure in right $\triangle ABD$ we get then $DQ = (120 - h)$ m

$$\tan 60^\circ = \frac{AB}{BD}$$

$$\sqrt{3} = \frac{AB}{h}$$

$$\Rightarrow AB = h\sqrt{3} \Rightarrow H = h\sqrt{3} \longrightarrow (1)$$

lly in right triangle PQD, we get

$$\tan 30^\circ = \frac{PQ}{DQ} = \frac{H}{120-h}$$

$$\Rightarrow \frac{1}{\sqrt{3}} = \frac{H}{120-h}$$

$$\Rightarrow H = \frac{120-h}{\sqrt{3}} \longrightarrow (2)$$

From (1) & (2) we get

$$h\sqrt{3} = \frac{120-h}{\sqrt{3}}$$

$$\Rightarrow h\sqrt{3} \times \sqrt{3} = 120 - h$$

$$\Rightarrow 3h + h = 120 \Rightarrow 4h = 120 \Rightarrow h = \frac{120}{4} = 30$$

From (1) $H = 30\sqrt{3}$ m.

And also $120 - h = 120 - 30 = 90$.

\therefore The heights of the poles are $30\sqrt{3}$ feet each and the distances of the point from the poles are 30 feet and 90 feet.

18. The angles of elevation of the top of a tower from two points at a distance of 4m and 9m. Find the height of the tower from the base of the tower and in the same straight line with it are complementary.

Sol: Height of the tower is AB say

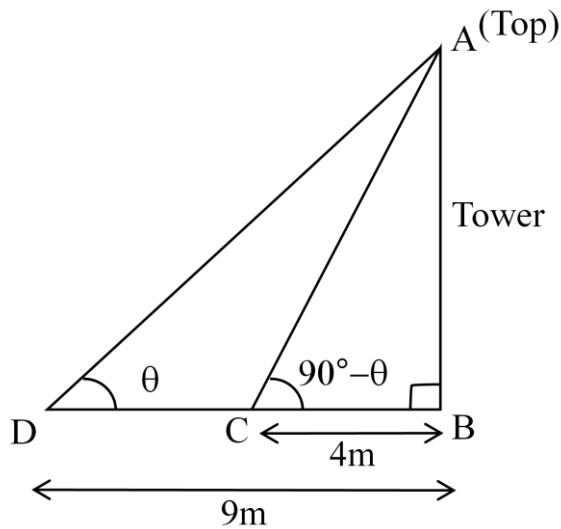

Let $\angle ADB = \theta$.

Then $\angle ACB = 90 - \theta$ (\because given)

($\because \angle ABD$ and $\angle ACB$ are Complementary)

In right triangle ABD

$$\tan \theta = \frac{AB}{DB} = \frac{AB}{9} \rightarrow (1)$$

In right triangle ΔABC

$$\tan(90^\circ - \theta) = \frac{AB}{4} \rightarrow (2)$$

$$\cot \theta = \frac{AB}{4}$$

Multiplying (1) and (2), we get

$$\frac{AB}{9} \times \frac{AB}{4} = \tan \theta \times \cot \theta$$

$$\frac{AB^2}{36} = \tan \theta \times \frac{1}{\tan \theta} = 1$$

$$\Rightarrow AB^2 = 36$$

$$\Rightarrow AB = 6\text{m}$$

\therefore The height of the tower is 6m.

- 19. The angle of elevation of a jet plane from a point A on the ground is 60° . After a flight of 15 seconds, the angle of elevation changes to 30° . If the jet plane is flying at a constant height of $1500\sqrt{3}$ meter, find the speed of the jet plane. ($\sqrt{3} = 1.732$)**

Sol: Let P, R be the two positions of the plane and A be the point of observation.

It is given that angles of elevation of the plane in A two positions P and R from point A are 60° and 30° . Respectively

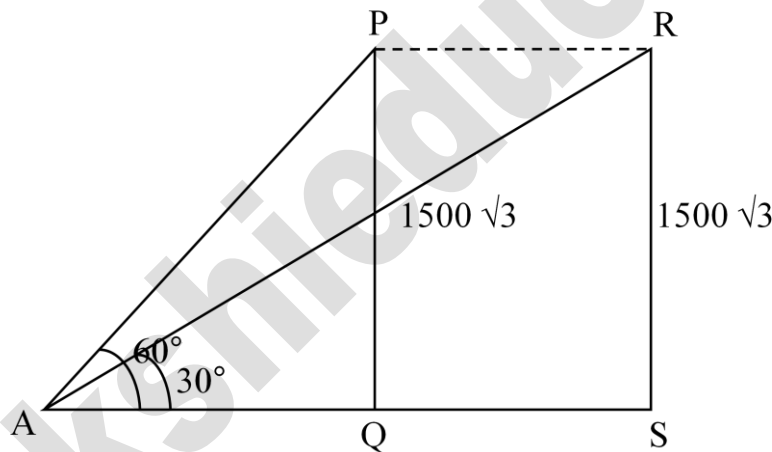

$$\Rightarrow \angle PAQ = 60^\circ \text{ and } \angle RAS = 30^\circ.$$

And also given that plane is flying at a constant height $PQ = Rs = 1500\sqrt{3}$.

Now, In ΔPAQ , we get

$$\tan 60^\circ = \frac{PQ}{AQ} = \frac{1500\sqrt{3}}{AQ}$$

$$\Rightarrow \sqrt{3} = \frac{1500\sqrt{3}}{AQ}$$

$$\Rightarrow AQ = \frac{1500\sqrt{3}}{\sqrt{3}} = 1500m.$$

In ΔRAS , we get

$$\tan 30^\circ = \frac{RS}{AS} = \frac{1500\sqrt{3}}{AS}$$

$$\Rightarrow \frac{1}{\sqrt{3}} = \frac{1500\sqrt{3}}{AS}$$

$$\Rightarrow AS = 1500\sqrt{3} \times \sqrt{3} = 1500 \times 3 = 4500.$$

\therefore Thus the distance which the plane travels $PR = RS = AS - AQ$

$$= 4500 - 1500 = 3000m.$$

$$\therefore \text{Speed of plane} = \frac{3000}{15} = 200m/sec.$$

Multiple Choice Questions

1. If the angle of elevation of the top of a tower at a distance of 500 m from the foot is 30° . Then the height of the tower is _____ []
a) $250\sqrt{3}m$ b) $500\sqrt{3}m$ c) $\frac{500}{\sqrt{3}}m$ d) 250m
2. A pole 6m high casts a shadow $2\sqrt{3}m$ long on the ground, then sun's elevation is _____ []
a) 60° b) 45° c) 30° d) 90°
3. The height of the tower is 100m. When the angle of elevation of sun is 30° , then shadow of the tower is _____ []
a) $100\sqrt{3}m$ b) 100m c) $100(\sqrt{3} - 1)m$ d) $\frac{100}{\sqrt{3}}m$
4. If the height and length of the shadow of a man are the same, then the angle of elevation of the sun is _____ []
a) 30° b) 60° c) 45° d) 15°
5. The angle of elevation of the top of a tower, whose height is 100m, at a point whose distance from the base of the tower is 100 m is _____ []
a) 30° b) 60° c) 45° d) none of these
6. The angle of elevation of the top of a tree height 2003 m at a point at distance of 200m from the base of the tree is _____ []
a) 30° b) 60° c) 45° d) None of these
7. A lamp post $5\sqrt{3}m$ high casts a shadow 5m long on the ground. The sun's elevation at this moment is _____ []
a) 30° b) 45° c) 60° d) 90°

8. Find the length of shadow of 10m high tree if the angle of elevation of the sun is 30°
- a) 10m b) $\frac{10}{\sqrt{3}}m$ c) $10\sqrt{3}m$ d) 20 m []
9. If the angle of elevation of a bird sitting on the top of a tree as seen from the point at a distance of 20m from the base of the tree is 60° . Then the height of the tree is _____ []
- a) $20\sqrt{3}m$ b) $10\sqrt{3}m$ c) 20m d) 10m
10. The tops of two poles of height 20m and 14m are connected by a wire. If the wire makes an angle of 30° with horizontal, then the length of the wire is _____ []
- a) 6m b) 8m c) 10m d) 12m

Key:

- 1) C; 2) A; 3) A; 4) C; 5) C; 6) C; 7) C; 8) C; 9) A; 10) D.

Fill in the Blanks

1. The ratio of the length of a tree and its shadow is $1 : \frac{1}{\sqrt{3}}$. The angle of the sun's elevation is _____ degrees
2. If two towers of height h_1 and h_2 subtend angles of 60° and 30° respectively at the mid-point of the line joining their feet, then $h_1 : h_2$ is _____
3. The line drawn from the eye of an observer to the object viewed is called _____
4. If the angle of elevation of the sun is 30° , then the ratio of the height of a tree with its shadow is _____
5. From the figure $\theta =$ _____

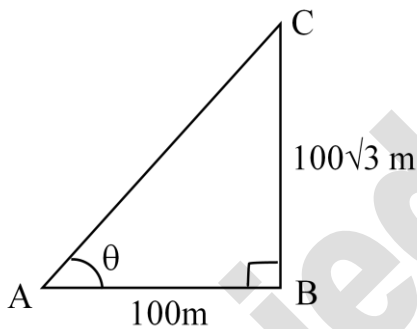

6. The angle of elevation of the sun is 45° . Then the length of the shadow of a 12m high tree is _____
7. When the object is below the horizontal level, the angle formed by the line of sight with the horizontal is called _____
8. When the object is above the horizontal level, the angle formed by the line of sight with the horizontal is called _____
9. The angle of depression of a boat is 60m high bridge is 60° . Then the horizontal distance of the boat from the bridge is _____

10. The height or length of an object can be determined with help of _____

Key

- 1) 60° ; 2) 3 : 1; 3) Line of sight; 4) $1 : \sqrt{3}$; 5) 60° ; 6) 12m;
7) angle of depression; 8) angle of elevation; 9) $20\sqrt{3}$ m; 10) Trigonometric ratios.

sakshieducation.com

Chapter-13

Probability

- The definition of probability was given by Pierre Simon Laplace in 1795
- J.Cardan, an Italian physician and mathematician wrote the first book on probability named the book of games of chance
- Probability has been used extensively in many areas such as biology, economics, genetics, physics, sociology etc.
- We use probability in forecast of weather, result of an election, population demography, earthquakes, crop production etc.

Random Experiment:

An experiment is said to be a random experiment if its outcome cannot be predicted that is the outcome of an experiment does not obey any rule.

- i. Tossing a coin is a random experiment
- ii. Throwing a die is a random experiment

Sample Space:

The set of all possible outcomes of an experiment are called a sample space (or) probability space

- If a coin is tossed, either head or tail may appear

Hence sample space (s) = {H,T}

Number of events $n(s) = 2$

- If a die is thrown once every face has equal chance to appear (1 or 2 or 3 or 4 or 5 or 6)

Hence sample space (s) = {1, 2, 3, 4, 5, 6}

Number of events $n(s) = 6$

Event: Any subset E of a sample space is called an event.

Ex: When a coin is tossed getting a head

Elementary Event: An event having only one outcome is called an elementary event

Ex: In tossing two coins {HH},{HT},{TH} and {TT} are elementary events.

Equally Likely Events: Two or more events are said to be equally likely if each one of them has an equal chance of occurrence

Ex: 1. When a coin is tossed, the two possible outcomes, head and tail, are

Equally likely

2. When a die is thrown, the six possible outcomes, 1, 2,3,4,5, and 6 are

Equally likely

Mutually Exclusive Events: Two or more events are mutually exclusive if the occurrence of each event prevents the every other event.

Ex: When a coin is tossed getting a head and getting a tail are mutually exclusive.

Probability: The number of occasions that a particular events is likely to occur in a large population of events is called **probability**

Theoretical Probability: The theoretical probability of an event is written as $P(E)$ and is defined as

$$P(E) = \frac{\text{Number of outcomes favourable to } E}{\text{Number of possible outcomes of the experiment}}$$

The sum of the probabilities, of all the elementary events of an experiments is 1

- **Complementary Events:** Event of all other outcomes in the sample survey which are not in the favorable events is called Complementary event.
- For any event E , $P(E) + P(\bar{E}) = 1$, Where \bar{E} stands for 'not E ' and E and \bar{E} are called complementary events

$$P(E) + P(\bar{E}) = 1 \Rightarrow P(\bar{E}) = 1 - P(E)$$

Exhaustive Events: All the events are exhaustive if their union is the sample space

Ex: when a die is thrown the events of getting an odd number, even number are mutually exhaustive.

Impossible Event: An event which will not occur on any account is called an Impossible event.

Ex: Getting '7' when a single die is thrown

Sure Event: The sample space of a random experiment is called sure or certain event.

Ex: When a die is thrown the events of getting a number less than or equal to 6

The probability of an event E is a number $P(E)$ such that $0 \leq P(E) \leq 1$

About Cards

- There are 52 cards in a pack of cards
- Out of these, 26 are in red colour and 26 are in black colour
- Out of 26 red cards, 13 are hearts (♥) and 13 are diamonds (♦)
- Out of 26 black cards, 13 are spades (♠) 13 are clubs (♣)
- Each of four varieties (hearts, diamonds, spades, clubs) has an ace. i.e

A pack of 52 cards has 4 aces. Similarly there are 4 kings, 4 queens and 4 jacks

1Mark Questions

1. **Sangeeta and Reshma, play a tennis match. It is known that the probability of Sangeeta wining the math is 0.62. What is the probability of Reshma winning the match .**

A. The probability of Sangeeta winning chances $P(S) = 0.62$

The probability of Reshmas winning chances $P(R) = 1 - P(S)$

$$= 1 - 0.62$$

$$= 0.38$$

2. **If $P(E) = 0.05$ what is the probability of not E?**

A. $P(E) + P(\text{not } E) = 1$

$$0.05 + P(\text{not } E) = 1$$

$$\therefore P(\text{not } E) = 1 - 0.05$$

$$= 0.95$$

3. **What is the probability of drawing out a red king from a deck of cards?**

A. Number of possible out comes = 52

$$\therefore n(s) = 52$$

The number of red king from a deck of cards = 2

$$\therefore n(E) = 2$$

$$\therefore P(E) = \frac{n(E)}{n(s)} = \frac{2}{52} = \frac{1}{26}$$

4. **What are complementary events?**

A. Consider an event has few outcomes. Event of all other outcomes in the sample survey which are not in the favorable event is called **complementary event**

5. **A die is thrown once find the probability of getting a even prime number**

A. Total no of outcomes = 6

$$n(s) = 6$$

No of outcomes favorable to a even prime number $E = 1$

$$\therefore n(E)=1$$

$$\therefore \text{Probability of getting a even prime } P(E) = \frac{n(E)}{n(s)} = \frac{1}{6}$$

6. Can $\frac{7}{2}$ be the probability of an event? Explain?

A. $\frac{7}{2}$ Can't be the probability of any event

Reason: probability of any event should be between 0 and 1

7. One card is drawn from a well-shuffled deck of 52 cards. Find the probability of getting a queen.

A. Number of outcomes favorable to the queen = 4

$$\therefore n(E) = 4$$

Number of all possible outcomes in drawing a card at random = 52

$$\therefore n(s) = 52$$

$$\text{Probability of event } P(E) = \frac{n(E)}{n(s)} = \frac{4}{52}$$

8. If $P(E) = \frac{1}{13}$ then find out p (not E)?

A. $P(E) = \frac{1}{13}$

$$P(E) + P(\bar{E}) = 1$$

$$\frac{1}{13} + P(\bar{E}) = 1$$

$$P(\bar{E}) = 1 - \frac{1}{13}$$

$$\frac{13-1}{13} = \frac{12}{13}$$

9. If a coin is tossed once what is the probability of getting a tail?

A. Number of all possible outcomes $s = 2$

$$\therefore n(s) = 2$$

Number of outcomes getting a tail $E = 1, \therefore n(E) = 1$

$$\therefore \text{Probability of event } P(E) = \frac{n(E)}{n(s)} = \frac{1}{2}$$

10. The probability of an event -1. In it true? Explain?

A. False. The probability of an event can never be negative it lies in between 0 and 1

11. A bag contain 3red and 2blue marbles. A marble is drawn at random. What is the probability of drawing a blue marbles

A. Total number of marbles = 3red + 2blue

$$n(s) = 5 \text{ marbles}$$

Favorable no of blue marbles = 2

$$n(E) = 2$$

Probability of getting blue marble

$$P(E) = \frac{n(E)}{n(s)} = \frac{2}{5}$$

12. What is a sample space?

A. The set of all possible outcomes of an event is called a sample space

13. What is the sum of fall probabilities of all elementary events of an experiment?

A. The sum of all probabilities of al elementary even of an experiment is 1.

14. Write an example for impossible event

A. When die is thrown the probability of getting 8 on the face.

2 Mark Questions

1. **Suppose we throw a die once.**

(i) What is the probability of getting a number getting a number greater than 4?

(ii) What is the probability of getting a number getting a number less than or equal to 4?

A. i) In rolling an unbiased dice

Sample space $s = \{1, 2, 3, 4, 5, 6\}$

No of outcomes $n(s) = 6$

Favorable outcomes for number greater than 4, $E = \{5,6\}$

No o favorable outcomes $n(E) = 2$

Probability $p(E) = \frac{2}{6} = \frac{1}{3}$

ii. Let F be the event getting a number less than or equal to 4

Sample space $s = \{1,2,3,4,5,6\}$

No of outcomes $n(s) = 6$

Favorable outcomes for number less or Equal to 4, $F = \{1,2,3,4\}$

No o favorable outcomes $n(F) = 4$

Probability $p(F) = P(F) = \frac{4}{6} = \frac{2}{3}$

2. **One card is drawn from a well shuffled deck of 52 cards calculate the probability that the card will (i) be an ace (ii) not be an ace**

A. Well shuffling ensures equally likely outcomes

i. There are 4 aces in a deck

Let E be the event the card is an ace

The number of the outcomes favorable to E = 4

The number of possible outcomes = 52

$$\therefore P(E) = \frac{4}{52} = \frac{1}{13}$$

- ii. Let F be the event card drawn is not an ace the number of outcomes favorable to the event $F = 52 - 4 = 48$

The number of possible outcomes = 52

$$\therefore P(E) = \frac{48}{52} = \frac{12}{13}$$

Alternate method: Note that F is nothing but \bar{E} .

Therefore can also calculate $P(F)$ as follows:

$$P(F) = P(\bar{E}) = 1 - P(E) = 1 - \frac{1}{13} = \frac{12}{13}$$

- 3. A bag contains lemon flavoured candies only Malini takes out one candy without locking in to the bag. What is the probability that she takes out**

i) An orange flavoured candy? ii) A lemon flavoured candy?

- A. Bag contains only lemon flavoured candies

- i. Taking an orange flavoured candy is an impossible event and hence the probability is zero
- ii. Also taking a lemon flavoured candy is a sure event and hence its probability is 1

- 4. A box contains 3blue, 2white and 4red marbles if a marble is drawn at random from the box, what is the probability that it will be**

i) White? ii) Blue? iii) Red?

- A. Saying that a marble is drawn at random means all the marbles are equally likely to be drawn

\therefore The number of possible outcomes = $3 + 2 + 4 = 9$

Let W denote the event 'the marble is white', B denote the event 'the marble is blue' and R denote the event 'the marble is red'.

- i. The number of outcomes favourable to the event $W = 2$

$$\text{So, } p(w) = \frac{2}{9}$$

$$\text{Similarly, ii) } P(B) = \frac{3}{9} = \frac{1}{3} \text{ and } P(R) = \frac{4}{9}$$

$$\text{Note that } P(W) + P(B) + P(R) = 1$$

5. Harpreet tosses two different coins simultaneously (say one is of one Rupee and other of two Rupee) . What is the probability that she gets at least one head?

- A. We write H for 'head' and T for 'Tail' when two coins are tossed simultaneously, The possible outcomes are (H,H),(H,T) ,(T,H) (T,T), which are all equally likely. Here (H,H) means heads on the first coin (say on 1Rupee) and also heads on the second coin (2Rupee) similarly (H,T) means heads up on the first coin and tail up on the second coin and so on

The outcomes favourable to the even E, at least one head are (H,H) , (H,T) and (T,H) so, the number of outcomes favourable to E is 3.

$$\therefore P(E) = \frac{3}{4} \text{ [Since the total possible outcomes = 4]}$$

i.e. the probability that Harpreet gets at least one head is $\frac{3}{4}$

6. A carton consists of 100 shirts of which 88 are good, 8 have minor defects and 4 have major defects. Jhony, a trader, will only accept the shirts which are good, but Sujatha, another trader, will only reject the shirts which have major defects .One shirt is drawn at random from the carton. what is the probability that
i) it is acceptable to Jhony? ii) it is acceptable to Sujatha?

- A. One shirt is drawn at random from the carton of 100 shirts . Therefore, there are 100equally likely outcomes.

- i. The number of outcomes favorable (i.e acceptable) to Jhony = 88

$$\therefore p(\text{shirt is acceptable to Jhony}) = \frac{88}{100} = 0.88$$

ii. The number of outcomes favourable to Sujatha = $88 + 8 = 96$

$$\text{so, } p(\text{shirt is acceptable to Sujatha}) = \frac{96}{100} = 0.96$$

7. A bag contains 3 red balls and 5 black balls. A ball is drawn at random from the bag what is the probability that the ball drawn is i) Red? ii) Not red?

A. i) Total number of balls in the bag = 3 red + 5 black = 8 balls

Number of total outcomes when a ball is drawn at random = $3 + 5 = 8$

Now, number of favourable outcomes of the red ball = 3

\therefore Probability of getting a red ball

$$= P(E) = \frac{\text{No. of favourable outcomes}}{\text{No. of total outcomes}} = \frac{3}{8}$$

ii. If $P(\bar{E})$ is the probability of drawing no red ball then $P(E) + P(\bar{E}) = 1$

$$P(\bar{E}) = 1 - P(E) = 1 - \frac{3}{8} = \frac{5}{8}$$

8. Gopi buys a fish from a shop for his aquarium the shopkeeper takes out one fish at random from a tank containing 5 male fish and 8 female fish what is the probability that the fish taken out is a male fish?

A. Number of male fishes = 5

Total number female fishes = 8

Total number of fishes = $5m + 8f = 13$ fishes

\therefore Number of total outcomes in taking a fish at random from the aquarium = 13

\therefore Number of outcomes favourable to male fish = 5

\therefore The probability of taking a male fish

$$= P(E) = \frac{\text{No. of favourable outcomes}}{\text{No. of total outcomes}}$$

No. of favourable outcomes / No. of total outcomes

$$\frac{5}{13} = 0.38$$

9. A bag contains 5 red and 8 white balls. If a ball is drawn at random from a bag, what is the probability that it will be i) white ball ii) not a white ball?

A. No. of red balls $n(R) = 5$

No. of white balls $n(w) = 8$

Total no. of balls = $5 + 8 = 13$

\therefore Total no. of outcomes $n(s) = 13$

i. No. of white balls $n(w) = 8$

No. of favourable outcome in drawing a white ball = 8

Probability of drawing white ball

$$= P(E) = \frac{\text{No. of favourable outcomes}}{\text{No. of total outcomes}} = \frac{8}{13}$$

ii. No. of balls which are not white balls = $13 - 8 = 5$

No. of favourable outcomes in drawing a ball which is not white balls = 5

$$P(\bar{W}) = \frac{5}{13}$$

10. Define i) equally likely events

ii) Mutually exclusive events

A. **i. Equally likely events:**

Two or more events are said to be equally likely if each one of them has an equal chance of occurrence

When a coin is tossed, getting a head and getting a tail are equally likely

ii. Mutually exclusive events:

Two events are mutually exclusive if the occurrences of one event precludes the occurrence of another event

When a coin is tossed getting a head and getting a tail are mutually exclusive

11. 12 defective pens are accidentally mixed with 132 good ones. It is not possible to just look at a pen and tell whether or not it is defective one pen is taken out at random from this lot determine the probability that the pen taken out is a good one

A. Number of good pens = 132

Number of defective pens = 12

Total numbers of pens = $132 + 12 = 144$

\therefore Total number of outcomes in taking a pen at random = 144

No. of favourable outcomes in taking a good pen = 132

\therefore Probability of taking a good pen

$$= \frac{\text{No. of favourable outcomes}}{\text{No. of total outcomes}} = \frac{132}{144} = \frac{11}{12}$$

12. What is the probability of drawing out a red king from a deck of cards?

A. Numbers of favourable outcomes to red king = 2

Number of total outcomes = 52

(\therefore Number of cards in a deck of cards = 52)

\therefore Probability of getting a red king p (red king)

$$= \frac{\text{No. of favourable outcomes}}{\text{No. of total outcomes}}$$

$$= \frac{2}{52} = \frac{1}{26}$$

13. A girl thrown a die with sides marked as A, B, C, D, E, F. what is the probability of getting i) A and d i)d

A. Faces of die are A, B, C, D, E, F. so the total outcomes = 6

$$n(s) = 6$$

i. Let the outcomes of getting 'A' $n(E) = 1$

$$\text{Probability of getting 'A'} \quad P(E) = \frac{n(E)}{n(S)} = \frac{1}{6}$$

Similarly let the outcomes of getting 'D' $n(E) = 1$

$$n(E) = 1$$

$$\text{Probability of getting D} \quad P(E) = \frac{n(E)}{n(S)} = \frac{1}{6}$$

14. Shyam and Ramulu visit a shop from Tuesday to Saturday. They may visit

The shop on a same day or another day. Then find the probability they have to visit on the same day

A. There are 5 days from Tuesday to Saturday so each visit the shop 5 times a

Week. So both are visit the shop in a week , $n(s) = 5 \times 5 = 25$

Suppose they visited the shop on the same day like (Tuesday, Tuesday) (Wednesday, Wednesday) (Thursday, Thursday) (Friday, Friday) and (Saturday, Saturday) $n(E) = 5$

$$\text{Probability of} \quad P(E) = \frac{n(E)}{n(S)} = \frac{5}{25} = \frac{1}{5}$$

4Mark Questions

1. Give examples of 5 experiments that have equally likely outcomes and five more examples that do not have equally likely outcomes

A. Equally likely events:

- a) Getting an even or odd number when a die is rolled.
- b) Getting a tail or head when a coin is tossed.
- c) Getting an even or odd number when a card is drawn at random from a pack of cards numbered from 1 to 10
- d) Drawing a green or black ball from a bag containing 8 green balls and 8 black balls.
- e) Selecting a boy or girl from a class of 20 boys and 20 girls

Events which are not equally likely:

- a) Getting a prime or composite number when a die is thrown.
- b) Getting an even or odd number when a card is drawn at random from a pack of cards numbered from 1 to 5.
- c) Getting a number which is a multiple of 3 or not a multiple of 3 from numbers 1, 2, ..., 10.
- d) Getting a number less than 5 or greater than 5.
- e) Drawing a white ball or green balls from a bag containing 5 green balls and 8 white balls.

2. Write a few new pair of events that are complementary.

- A.
- a) When a die is thrown, getting an even number is complementary to getting an odd number.
 - b) Drawing a red card from a deck of cards is complementary to getting a black card
 - c) Getting an even number is complementary to getting an odd number from number 1, 2, ..., 8.
 - d) Getting a Sunday is complementary to getting any day other than Sunday in a week.

e) Winning a running race is complementary to losing it.

3. Sarada and Hamida are friends. What is the probability that both will have i) different birthdays? ii) The same birthday? (Ignoring a leap year)

A. Out of the two friends, one girl, say, Sarada's birthday can also be any day of 365 days in the year. We assume that these 365 days in the year we assume that these 365 days in the year. We assume that these 365 outcomes are equally likely.

i) If Hamida's birthday is different from Sarada's the number of favourable outcomes for her birthday is $365 - 1 = 364$

So, $p(\text{Hamida's birthday is different from Sarada's birthday}) = \frac{364}{365}$

ii) $p(\text{Sarada and Hamida have the same birthday})$

$$= 1 - p(\text{both have different birthdays})$$

$$= 1 - \frac{364}{365} \quad (\text{Using } p(\bar{E}) = 1 - P(E)) = \frac{1}{365}$$

4. There are 40 students in X class of a school of whom 25 are girls and 15 are boys. The class teacher has to select one student as a class representative. She writes the name of each student on a separate card, the cards being identical. Then she puts cards in a box and stirs them thoroughly. She then draws one card from the box. What is the probability that the name written on the card is the name of i) a girl? ii) a boy?

A. There are 40 students and only one name card has to be chosen the number of all possible outcomes is 40.

i) The no. of all possible outcomes (favourable for a card with the name of a girl) = 25

$$\therefore p(\text{card with name of a girl}) = p(\text{Girl}) = \frac{25}{40} = \frac{5}{8}$$

ii) The no. of outcomes favourable for a card with the name of a boy = 15

$$\therefore p(\text{card of name of a boy}) = p(\text{boy}) = \frac{15}{40} = \frac{3}{8}$$

$$(Or) p(\text{boy}) = 1 - p(\text{not boy}) = 1 - p(\text{Girl}) = 1 - \frac{5}{8} = \frac{3}{8}$$

5. Rahim takes out all the hearts from the cards what is the probability of

i) Picking out an ace from the remaining pack

ii) Picking out a diamonds.

iii) Picking out a card that is not a heart

iv) Picking out the ace of hearts

A. Total number of cards in the deck = 52

Total number of hearts in the deck and of cards = 13

When hearts are removed, remaining cards = $52 - 13 = 39$

i) Picking an ace:

No of outcomes favourable to ace = 3

Total no of possible outcomes from the remaining cards = 39-after removing hearts

$$\text{Probability } p(A) = \frac{\text{No. of favourable outcomes}}{\text{total no of outcomes}}$$

$$\frac{3}{39} = \frac{1}{13}$$

ii) Picking a diamond:

No of favourable outcomes to diamonds = 13

Total no of possible outcomes = 39 (♦)

$$\therefore p(\diamond) = \frac{13}{39} = \frac{1}{3}$$

iii) Picking a card not heart

As all hearts are removed it is an impossible event and hence it's probability is zero

$$\text{Heart } p(\heartsuit) = \frac{0}{39} = 0$$

iv) Picking out the ace of hearts:

a) If drawn from the removed cards

No of favourable outcomes = 1

Total no of possible outcomes = 13

$$\therefore P(E) = \frac{1}{13}$$

b) If the picking from the rest of the cards, it is an impossible event and hence probability is zero

6. A box contains 5 red marbles, 8 white marbles and 4 green marbles. One marble is taken out of the box at random. What is the probability that the marble taken out will be i) red ii) white ? iii) not green?

A. Total number of marbles in the box

$$5\text{red} + 8\text{wht} + 4\text{green}$$

$$= 5 + 8 + 4 = 17$$

\therefore No of total outcomes in drawing a marble at random from the box = 17

i) No of red marbles = 5

No of favourable outcomes in drawing a red ball = 5

$$\therefore P(R) = \frac{\text{No. of favourable outcomes}}{\text{No. of total outcomes}}$$

$$P(R) = \frac{5}{17}$$

ii) No of white marbles = 8

No of favourable outcomes in drawing a white marble = 8

\therefore probability of getting a white marble

$$= P(W) = \frac{\text{No. of favourable outcomes}}{\text{No. of total outcomes}}$$

$$P(w) = \frac{8}{17}$$

iii) No of “non green” marbles = 5red + 8white

$$= 5 + 8 = 13$$

No of outcomes favourable to drawing a non green marble = 13

∴ Probability of getting a non-green marble

$$P(\text{non-green}) = \frac{\text{No. of favourable outcomes}}{\text{No. of total outcomes}}$$

$$P(\text{non-green}) = \frac{13}{17}$$

7. A kiddy bank contains hundred 50p coins, fifty 1Rupee coins, twenty 2rupee coins and ten 5rupee coins. If it is equally likely that one of the coins will fall out when the kiddy bank is turned upside down, what is the probability of that the coin i) will be a 50p coins ?

ii) will not be a 5rupee coin?

A. i) No of 50p coins = 100

No of 1 rupee cons = 50

No of 2 rupee cons = 20

No of 5 rupee coins = 10

Total no of coins = 180

∴ No of total outcomes for a coin to fall down = 180

No of outcomes favourable to 50p coins to fall down =

$$\frac{\text{No. of favourable outcomes}}{\text{No. of total outcomes}} = \frac{100}{180} = \frac{5}{9}$$

ii) Let $P(E)$ be the probability for a 5Rupee coin to fall down.

No of outcomes favourable to 5Rupee coin = 10

Probability for a 5Rupee coins to fall down

$$\frac{\text{No. of favourable outcomes}}{\text{No. of total outcomes}}$$

$$\frac{10}{180} = \frac{1}{18}$$

Then the $P(\bar{E})$ is the probability of a coin which fall down is not a 5Rupee coin

$$P(E) + P(\bar{E}) = 1$$

Again

$$\therefore P(\bar{E}) = 1 - P(E)$$

$$= 1 - \frac{1}{18} = \frac{17}{18}$$

8. A game of chance consists of spinning an arrow which comes to rest pointing at one of the number 1,2,3,4,5,6,7,8 and these are equally likely outcomes what is the probability that it will point at

i) 8?

ii) an odd number?

iii) a number greater than 2?

iv) a number less than 9?

A. No of total outcomes are $(1,2..8) = 8$

i) No of outcomes favourable to 8 = 1

$$\therefore P(S) = \frac{\text{No. of favourable outcomes}}{\text{No. of total outcomes}} = \frac{1}{8}$$

ii. No of odd number on the spinning wheel = $(1,3,5,7) = 4$

\therefore No of outcomes favourable to an odd number

\therefore Probability of getting an odd number

$$P(\text{odd}) = \frac{\text{No. of favourable outcomes}}{\text{No. of total outcomes}} = \frac{4}{8} = \frac{1}{2}$$

iii) No of chances greater than 2 are (3,4,5,6,7,8)

No of outcomes favourable to greater than 2 are = 6

∴ Probability of pointing a number greater than 2

$$P(E) = \frac{\text{No. of favourable outcomes}}{\text{No. of total outcomes}}$$

$$= \frac{6}{8} = \frac{3}{4}$$

iv) No of less than 9 are (1,2,3,4,5,6,7,8) = 8

∴ No of outcomes favourable to pointing a number less than 9 = 8

$$P(E) = \frac{\text{No. of outcomes favourable to less than 9}}{\text{No. of total outcomes}}$$

$$= \frac{8}{8} = 1$$

Note: This is a sure event and hence probability is 1.

9. One card is drawn from a well-shuffled deck of 52 cards. Find the probability of getting

- i) a king of red colour ii) a face card iii) a red face card**
iv) The jack of hearts v) a spade vi) The queen of diamonds.

A. Total no of cards = 52

∴ No of all possible outcomes in drawing a card at random = 52

i) No of outcomes favourable to the king of red colour.

$$= \frac{\text{No. of favourable outcomes}}{\text{No. of total outcomes}}$$

$$= \frac{2}{52} = \frac{1}{26}$$

ii) No of face cards in deck of cards = $4 \times 3 = 12$ (K, Q, J)

No of outcomes favourable to draw a face card = 12

Probability of getting a face card

$$= \frac{\text{No. of favourable outcomes}}{\text{No. of total outcomes}}$$

$$= \frac{12}{52} = \frac{3}{13}$$

iii) No of red face card = $2 \times 3 = 6$

∴ No of outcomes favourable to draw a red face card = 6

∴ Probability of getting a red face card

$$= \frac{\text{No. of favourable outcomes}}{\text{No. of total outcomes}}$$

$$= \frac{6}{52} = \frac{3}{26}$$

iv) No of outcomes favourable to the jack of hearts = 1

∴ Probability of getting jack of hearts

$$= \frac{\text{No. of favourable outcomes}}{\text{No. of total outcomes}}$$

$$= \frac{1}{52}$$

v) No of spade cards = 13

∴ No of outcomes favourable to a spade card = 13

∴ Probability of drawing a spade card

$$= \frac{\text{No. of favourable outcomes}}{\text{No. of total outcomes}} = \frac{13}{52} = \frac{1}{4}$$

vi) No of outcomes favourable to the queen of diamonds = 1

∴ Probability of drawing the queen of diamonds

$$= \frac{\text{No. of favourable outcomes}}{\text{No. of total outcomes}} = \frac{1}{52}$$

10. Five cards the ten, jack, queen, king, ace of diamonds, are well shuffled with their face downwards one card is then picked up at random

i) What is the probability that the card is queen?

ii) If the queen is drawn and put aside, what is the probability that the second card picked up is (a) an ace ? (b) a queen?

A. Total no of cards = 5

∴ No of total outcomes in drawing a card at random = 5

i) No of outcomes favourable to queen = 1

∴ Probability of getting the queen

$$= \frac{\text{No. of favourable outcomes 'Q'}}{\text{No. of total outcomes}} = \frac{1}{5}$$

ii) When queen is drawn and put aside, remaining cards are four

∴ No of total outcomes in drawing a card at random = 4

a) No of favourable outcomes to ace = 1

probability of getting an ace =

$$= \frac{\text{No. of favourable outcomes}}{\text{No. of total outcomes}} = \frac{1}{4}$$

b) No of favourable outcomes to 'Q' = 0 (as it was already drawn and put aside)

$$\therefore \text{Probability that the card is Q} = \frac{0}{4} = 0$$

11. A box contains 90 discs which are numbered from 1 to 90. If one disc is drawn at random from the box find the probability that it bears

i) a two digit number ii) a perfect square number iii) a number divisible by 5.

A. Total number of discs in the box = 90

∴ No of total outcomes in drawing a disc at random from the box = 90

i) No of 2-digit numbers in the box = 81 i.e No of favourable outcomes in drawing a disc bearing a 2-digit number

$$= \frac{\text{No. of favourable outcomes}}{\text{No. of total outcomes}} = \frac{81}{90} = \frac{9}{10} = 0.9$$

ii) No of favourable perfect squares in the box

$$(1^2 = 1, 2^2 = 4, 3^2 = 9, 4^2 = 16, 5^2 = 25, 6^2 = 36, 7^2 = 49, 8^2 = 64, 9^2 = 81)$$

i.e no of favorable outcomes in drawing a disc with a perfect square

$$= \frac{\text{No. of favourable outcomes}}{\text{No. of total outcomes}} = \frac{9}{90} = \frac{1}{10}$$

iii) No of multiples of 5 from 1 to 90 are (5, 10...90) = 18

i.e no of favourable outcomes in drawing a disc with a multiple of 5 = 18

∴ Probability of drawing a disc bearing a number multiple by 5

$$= \frac{\text{No. of favourable outcomes}}{\text{No. of total outcomes}}$$

$$= \frac{18}{90} = \frac{1}{5}$$

12. Two dice are rolled simultaneously and counts are added i) complete the table given below

Event: sum on 2 dice	2	3	4	5	6	7	8	9	10	11	12
Probability	$\frac{1}{36}$						$\frac{5}{36}$				$\frac{12}{36}$

ii) A student argues that there are 11 possible outcomes 2,3,4,5,6,7,8,9,11,12.

Therefore each of the has a probability $\frac{1}{11}$. Do you agree with this argument? Justify your answer

A. When two dice are rolled, total number of outcomes = 36

	1	2	3	4	5	6
1	1,1	1,2	1,3	1,4	1,5	1,6
2	2,1	2,2	2,3	2,4	2,5	2,6
3	3,1	3,2	3,3	3,4	3,5	3,6
4	4,1	4,2	4,3	4,4	4,5	4,6
5	5,1	5,2	5,3	5,4	5,5	5,6
6	6,1	6,2	6,3	6,4	6,5	6,6

Sum on 2dice	Favourable outcomes	No. of favourable outcomes	Probability
2	(1,1)	1	$\frac{1}{36}$
3	(1,2)(2,1)	2	$\frac{2}{36} = \frac{1}{18}$
4	(1,3)(2,2)(3,1)	3	$\frac{3}{36} = \frac{1}{12}$
5	(1,4)(2,3)(3,2)(4,1)	4	$\frac{4}{36} = \frac{1}{9}$
6	(1,5)(2,4)(3,3)(4,2)(5,1)	5	$\frac{5}{36}$
7	(1,6)(2,5)(3,4)(4,3)(5,2)(6,1)	6	$\frac{6}{36} = \frac{1}{6}$
8	(2,6)(3,5)(4,4)(5,3)(6,2)	5	$\frac{5}{36}$
9	(3,6)(4,5)(5,4)(6,3)	4	$\frac{4}{36} = \frac{1}{9}$
10	(4,6)(5,5)(6,4)	3	$\frac{3}{36} = \frac{1}{12}$

11	(5,6)(6,5)	2	$\frac{2}{36} = \frac{1}{18}$
12	(6,6)	1	$\frac{1}{36}$

ii) The above argument is wrong. The sum 2,3,4...& 12 have different no of favourable outcomes, moreover total number of outcomes are 36

13. A game consists of tossing a one rupee coin 3 times and noting it's outcome each time. Hanif wins if all the tosses give the same result . i.e three heads or three tails and losses otherwise calculate the probability that Hanif will lose the game

A. When a coin is tossed for n times the total number of outcomes = 2^n

∴ If a coin is tossed for 3-times, then the total number of outcomes = $2^3 = 8$

Note the following:

T T T
 T T H
 T H T
 H T T
 H H T
 H T H
 T H H
 H H H

Of the above no of outcomes with different results = 6

probability of losing the game

$$= \frac{\text{No. of favourable outcomes}}{\text{No. of total outcomes}} = \frac{6}{8} = \frac{3}{4}$$

14. A die is thrown twice. What is the probability that i) 5 will not come up either time? ii) 5 will come up at least once? (Hint: Throwing a die twice and throwing two dice simultaneously are treated as the same experiment)

A. If a die is thrown n-times or n-dice are thrown simultaneously then the total number of outcomes = $6 \times 6 \times 6 \dots \times 6$ (n-times) = 6^n

No of total outcomes in throwing a die for two times = $6^2 = 36$

	1	2	3	4	5	6
1	1,1	1,2	1,3	1,4	1,5	1,6
2	2,1	2,2	2,3	2,4	2,5	2,6
3	3,1	3,2	3,3	3,4	3,5	3,6
4	4,1	4,2	4,3	4,4	4,5	4,6
5	5,1	5,2	5,3	5,4	5,5	5,6
6	6,1	6,2	6,3	6,4	6,5	6,6

Let E be the event that 5 will not come up either time, then the favorable outcomes are (1,1)(1,2)(1,3)(1,4)(1,6)(2,1)(2,2)(2,3)(2,4)(2,6)(3,1)(3,2)(3,3)(3,4)(3,6)(4,1)4,2(4,3)4,4(4,6)(6,1)(6,2)(6,3)(6,4)(6,5)(6,6) = 25

$$P(E) = \frac{\text{No. of favourable outcomes}}{\text{No. of total outcomes}} = \frac{25}{36}$$

ii) Let E be the event that 5 will come up at least once then the favourable outcomes are (1,5)(2,5)(3,5)(4,5)(5,5)(6,5)(5,1)(5,2)(5,3)(5,4)(5,5)(5,6) = 11

$$P(E) = \frac{\text{No. of favourable outcomes}}{\text{No. of total outcomes}} = \frac{11}{36}$$

Fill in the blanks

1. R = Red, Y = yellow. From the figure, the probability to get yellow colour ball is _____
2. A game of chance consists of spinning an arrow which comes to rest at one of the number 1,2,3,4,5,6,7,8 and these are equally likely outcomes the possibilities that the arrow will point at a number greater than 2 is _____
3. For any event E, $P(E) + P(\bar{E}) =$ _____
4. When a die is thrown once, the possible number of outcomes is _____
5. The probability of an event lies between _____ and _____
6. If two events have same chances to happen then they are called _____
7. In a single throw of two dice, the probability of getting distinct numbers is _____
8. $P(E) = \frac{1}{3}$ then $p(\bar{E}) =$ _____
9. "The book of games of chance" was written by _____
10. Getting "7" when a single die is throw is an example of _____
11. The probability of a baby born either boy (or) girl is _____
12. When a die is thrown the event of getting numbers less than are equal to 6 is an example _____ event
13. If a card is drawn from a pack the probability that it is a king is _____
14. The probability of an event that cannot happen is _____
15. The probability of an event is 1.5. Is it true (or) false _____
16. If a two digit number is chosen at random that the probability that the number chosen is a multiple of 3 is _____

17. A number is selected at random from the 3,5,5,7,7,7,9,9,9,9. Then the probability that the selected number is their average is _____
18. If a number X is chosen from the number 1,2,3 and a number Y is selected from the numbers 1,4,9 then $p(XY < 9)$ is _____
19. A card is drawn dropped from a pack of 52 playing cards the probability that it is an ace is _____
20. Suppose you drop a die at random in the rectangular region shown in the figure what is the probability that it will land inside the circle with diameter 1m_____

Answers

1) $\frac{2}{5}$

2) $\frac{3}{4}$

3) 1

4) 6

5) 0,1

6) Equally

7) $6^2 = 36$

8) $\frac{2}{3}$

9) j.cardon 10) impossible

11) $\frac{1}{2}$

12) sure

13) $\frac{1}{13}$

14) 0

15) false

16) $\frac{1}{3}$

17) $\frac{3}{10}$

18) $\frac{5}{6}$

19) $\frac{1}{13}$

20) $\frac{11}{84}$

Chapter 14 - Statistics

1 Marks Questions

1. Write three formulas to find the mean

Sol: Three formulas to find the mean:

i) The Direct Method: $\bar{x} = \frac{\sum fix_i}{\sum f_i}$

ii) The assumed mean Method: $\bar{x} = a + \frac{\sum fidi}{\sum f_i}$

iii) The step deviation Method: $\bar{x} = a + \left[\frac{\sum fiui}{\sum f_i} \right] \times h$

2. Find the mean for first 100 natural numbers.

Sol: First 100 natural numbers = 1, 2, 3,100

$$\text{Sum of first } n \text{ natural numbers} = \frac{n(n+1)}{2}$$

$$\text{Sum of first 100 natural numbers} = \frac{100(100+1)}{2}$$

$$= \frac{100(101)}{2} = 50 \times 101$$

\therefore Mean of first 100 natural numbers

$$= \frac{\text{sum of observations}}{\text{No. of observations}} = \frac{50 \times 101}{100}$$

$$= 50.5$$

3. Find the mean if $\sum f_i x_i = 1860$ and $\sum f_i = 30$.

Sol: $\sum f_i x_i = 1860$, $\sum f_i = 30$

$$\text{Mean} = \frac{\sum fix_i}{\sum f_i} = \frac{1860}{30} = 62$$

4. Find the mode of $\frac{1}{3}, \frac{3}{4}, \frac{5}{6}, \frac{1}{2}, \frac{7}{12}$

Sol: Given observations = $\frac{1}{3}, \frac{3}{4}, \frac{5}{6}, \frac{1}{2}, \frac{7}{12}$

$$\begin{array}{r} 3 \overline{)3, 4, 6, 2, 12} \\ 2 \overline{)1, 4, 2, 2, 4} \\ \underline{1, 2, 1, 1, 2} \end{array}$$

No. of observations = 5

Sum of observations = $\frac{1}{3} + \frac{3}{4} + \frac{5}{6} + \frac{1}{2} + \frac{7}{12}$

$$\frac{108}{24} = \frac{9}{2} = 4.5$$

5. Find mode if a = 47.5, $\sum f_i d_i = 435$ and $\sum f_i = 30$.

Sol: Given that: a = 47.5

$$\sum f_i d_i = 435$$

$$\sum f_i = 30$$

$$\text{Mode } \bar{x} = a + \frac{\sum f_i d_i}{\sum f_i}$$

$$= 47.5 + \frac{435}{30}$$

$$= 47.5 + \frac{145}{10}$$

$$= 47.5 + 14.5$$

$$= 62$$

6. Find the mode of first n natural numbers

Sol: first n natural numbers = 1, 2, 3, 4, n.

In this series any number is not repeated so, there is no mode for this numbers

(**Note:** If there is no mode for any problem. We cannot say that the mode is '0')

7. The wickets taken by a bowler in 10 cricket matches are as follows: 2, 6, 4, 5, 0, 2, 1, 3, 2, 3. Find the mode of the data.

Sol: Let us arrange the observations in order i.e. 0, 1, 2, 2, 2, 3, 4, 5, 6.

Clearly 2 is the number of wickets taken by the bowler in the maximum number of matches (i.e., 3 times). So, the mode of this data is 2.

8. Find the mode of given data 5, 6, 9, 10, 6, 12, 3, 6, 11, 10, 4, 6, 7

Sol: Given data: 5, 6, 9, 10, 6, 12, 3, 6, 11, 10, 4, 6, 7

∴ Ascending order: 3, 4, 5, 6, 6, 6, 6, 7, 9, 10, 10, 11, 12

∴ Mode = 6

9. Find the mode of given data 2, 2, 2, 3, 3, 3, 4, 4, 4, 5, 5, 5, 6, 6, 6

Sol: Given data 2, 2, 2, 3, 3, 3, 4, 4, 4, 5, 5, 5, 6, 6, 6

Mode of given data = 2, 3, 4, 5 and 6.

10. Write the formula to find the median.

Sol: Median (M) = $l + \left[\frac{\frac{n}{2} - cf}{f} \right] \times h$

11. Find the median if, $l = 60$, $cf = 22$, $f = 7$, $h = 10$, and $\frac{n}{2} = 26.5$

Sol: Give that

$$l = 60$$

$$cf = 22$$

$$f = 7$$

$$h = 10$$

$$\frac{n}{2} = 26.5$$

$$\text{Median (M)} = l + \left[\frac{\frac{n}{2} - cf}{f} \right] \times h$$

$$= 60 + \left[\frac{26.5 - 22}{7} \right] \times 10$$

$$= 60 + \left[\frac{4.5}{7} \right] \times 10$$

$$= 60 + \frac{45}{70} \times 10$$

$$= 60 + \frac{45}{7}$$

$$= 60 + 6.4$$

$$= 66.4.$$

12. What are ogive curves?

Sol: cumulative frequency curve or an ogive:

First we prepare the cumulative frequency table, and then the cumulative frequencies are plotted against the upper or lower limits of the corresponding class intervals. By joining the points the curve so obtained is called a cumulative frequency or ogive.

2 Mark Questions

1. The marks obtained in mathematics by 30 students of class X of a certain school are given in table below. Find the mean of the marks obtained by the students.

Marks obtained (x_i)	10	20	36	40	50	56	60	70	72	80	88	92	95
No.of student (f_i)	1	1	3	4	3	2	4	4	1	1	2	3	1

Sol: let us re-organize this data and find the sum of all observations

Marks obtained (x_i)	Number of students (f_i)	$f_i x_i$
10	1	10
20	1	20
36	3	108
40	4	160
50	3	150
56	2	112
60	4	240
70	4	280
72	1	72
80	1	80
88	2	176
92	3	276
95	1	95
Total	$\sum f_i = 30$	$\sum f_i x_i = 1779$

$$\text{So, } \bar{x} = \frac{\sum f_i x_i}{\sum f_i} = \frac{1779}{30} = 59.3$$

∴ The mean marks are 59.3.

2. Write mean formula in deviation method? Explain letters in it.

Sol: $\text{mean } \bar{x} = a + \frac{\sum f_i u_i}{\sum f_i} \times h$

‘a’ is class mark of mean class

‘ f_i ’ is the highest frequency

$u_i = \frac{x_i - a}{h}$, Here x_i = mid value of classes

a = assumed mid value

h = class size

$\sum f_i x_i$ = sum of total frequency.

3. A survey was conducted by a group of students as a part of their environment awareness programme, in which they collected the following data regarding the number of plants in 20 houses in a locality. Find the mean number of plants per house.

Number of plants	0 – 2	2 – 4	4 – 6	6 – 8	8 – 10	10 – 12	12 – 14
Number of house	1	2	1	5	6	2	3

No. of plants	No. of houses f_i	Class marks x_i	$f_i x_i$
0 – 2	1	1	1
2 – 4	2	3	6
4 – 6	1	5	5
6 – 8	5	7	35
8 – 10	6	9	54

10 – 12	2	11	22
12 – 14	3	13	39
Total	$\sum f_i = 20$		$\sum f_i x_i = 162$

$$\begin{aligned} \text{Mean} &= \frac{\sum f_i x_i}{\sum f_i} \\ &= \frac{162}{20} \\ &= 8.1 \end{aligned}$$

∴ 8 plants are planted at each house.

4. The table below shows the daily expenditure on food of 25 households in a locality.

Daily expenditure (Rs)	100 – 150	150 – 200	200 -250	250 – 300	300 – 350
No. of house holds	4	5	12	2	2

Find the mean daily expenditure on food by a suitable method

Daily expenditure (in Rupees)	No. of households (f_i)	Class Marks (x_i)	$f_i x_i$
100 – 150	4	125	500
150 – 200	5	175	875
200 -250	12	225	2700
250 – 300	2	275	550
300 – 350	2	325	650
	$\sum f_i = 25$		$\sum f_i x_i = 5275$

$$\text{Mean} = \frac{\sum f_i x_i}{\sum f_i} = \frac{5275}{25} = 211$$

The mean daily expenditure on food of a house hold is Rs. 211.

5. Write the formula of mode in a grouped data and explain the letters in it.

Sol:
$$\text{Mode} = l + \left[\frac{f_1 - f_0}{2f_1 - f_0 - f_2} \right] \times h$$

Where, l = lower boundary of the modal class

h = size of the modal class interval

f_1 = frequency of the modal class

f_0 = frequency of the class preceding the modal class

f_2 = frequency of the class succeeding the modal class

6. Write the formula of median in a grouped data and explain the letters in it.

Sol: **Median for a grouped data:**

$$\text{Median} = l + \left[\frac{\frac{n}{2} - cf}{f} \right] \times h$$

Where, l = lower boundary of median class

n = number of observations

cf = cumulative frequency of class preceding the median class

f = frequency of median class

h = size of the median class

7. The mean of the following distribution is 53. Find the missing frequency p?

Classes	0 – 20	20 – 40	40 – 60	60 – 80	80 – 100
Frequency	12	15	32	P	13

Sol:

Class	Class mark	f_i	$f_i x_i$
0 – 20	10	12	120
20 – 40	30	15	450
40 – 60	50	32	1600

60 – 80	70	P	70p
80 – 100	90	13	1170
		$\sum f_i = 72 + p$	$\sum f_i x_i = 3340 + 70p$

$$\text{mean } \bar{x} = \frac{\sum f_i x_i}{\sum f_i} \Rightarrow \frac{53}{1} = \frac{3340 + 70p}{72 + p}$$

$$3340 + 70p = 53(72 + p)$$

$$3340 + 70p = 3816 + 53p$$

$$70p - 53p = 3816 - 3340$$

$$17p = 476$$

$$p = \frac{476}{17}$$

$$P = 28.$$

8. Find the unknown entries a, b, c, d in the following distribution of heights of students in a class.

Height (in cm)	Frequency	Cumulative frequency
150 – 155	12	12
155 – 160	a	25
160 – 165	10	b
165 – 170	c	43
170 – 175	5	48
175 – 180	2	d

$$a = 25 - 12 = 13$$

$$b = 25 + 10 = 35$$

$$c = 43 - 35 = 8$$

$$d = 48 + 2 = 50$$

9. Prepare less than cumulative frequency distribution and greater than cumulative frequency distribution for the following data.

Daily income (in rupees)	250 – 300	300 – 350	350 – 400	400 – 450	450 – 500
No. of workers	12	14	8	6	10

Sol: Less than cumulative frequency

Daily income (in Rs)	No. of workers	Upper limits	Less than cumulative frequency
250 – 300	12	300	12
300 – 350	14	350	$12 + 14 = 26$
350 – 400	8	400	$12 + 14 + 8 = 34$
400 – 450	6	450	$12 + 14 + 8 + 6 = 40$
450 – 500	10	500	$12 + 14 + 8 + 6 + 10 = 50$

Greater than cumulative frequency

Daily income (in Rs)	No. of workers	lower limits	Greater than cumulative frequency
250 – 300	12	250	$12 + 14 + 8 + 6 + 10 = 50$
300 – 350	14	300	$14 + 8 + 6 + 10 = 40$
350 – 400	8	350	$8 + 6 + 10$
400 – 450	6	400	$6 + 10 = 16$
450 – 500	10	450	$10 = 10$

10. Median of a data, arranged in ascending order 7, 10, 15, x, y, 27, 30 is 17 and when one more observation 50 is added to the data, the median has become 18 find x and y.

Sol: Given data:

7, 10, 15, x, y, 27, 30

\therefore Median = x.

\therefore x = 17 (\because median = 17)

One more observation 50 is added then data is 7, 10, 15, x, y, 27, 30, 50.

\therefore Median = $\frac{x+y}{2}$

$18 = \frac{x+y}{2}$ [\because median is 18]

x + y = 36

17 + y = 36 \Rightarrow y = 36 - 17 = 19

\therefore x = 17, y = 19.

11. Prepare class interval frequency follow table.

Marks obtained	Less than 10	Less than 20	Less than 30	Less than 40	Less than 50
No. of students	5	8	12	18	25

Sol:

Marks obtained	No. of students	Class in marks	Frequency
Less than 10	5	0 - 10	5
Less than 20	8	10 - 20	8 - 5 = 3
Less than 30	12	20 - 30	12 - 8 = 4
Less than 40	18	30 - 40	18 - 12 = 6
Less than 50	25	40 - 50	25 - 18 = 7

12. In the calculation of mean problem, $\bar{x} = 62$, $\sum f_i d_i = 435$, $a = 47.5$ then what is the value of $\sum f_i$.

Sol: We know that, $\bar{x} = a + \frac{\sum f_i d_i}{\sum f_i}$

given, $\bar{x} = 62$, $\sum f_i d_i = 435$, $a = 47.5$, $\sum f_i = ?$

$$62 = 47.5 + \frac{435}{\sum f_i}$$

$$62 - 47.5 = \frac{435}{\sum f_i}$$

$$14.5 = \frac{435}{\sum f_i}$$

$$\sum f_i = \frac{435}{14.5}$$

$$= \frac{4350}{145}$$

$$f_i = 30.$$

4 Mark Questions

1. The following distribution gives the daily income of 50 workers of a factory.

Sol:

Daily income	250 – 300	300 – 350	350 – 400	400 – 450	450 – 500
No.of workers	12	14	8	6	10

Convert the distribution above to a less than type cumulative frequency distribution and draw it's ogive.

Class interval	f	cf	Points
Less than 300	12	12	(300, 12)
Less than 350	14	26	(350, 26)
Less than 400	8	34	(400, 34)
Less than 450	6	40	(450, 40)
Less than 500	10	50	(500, 50)

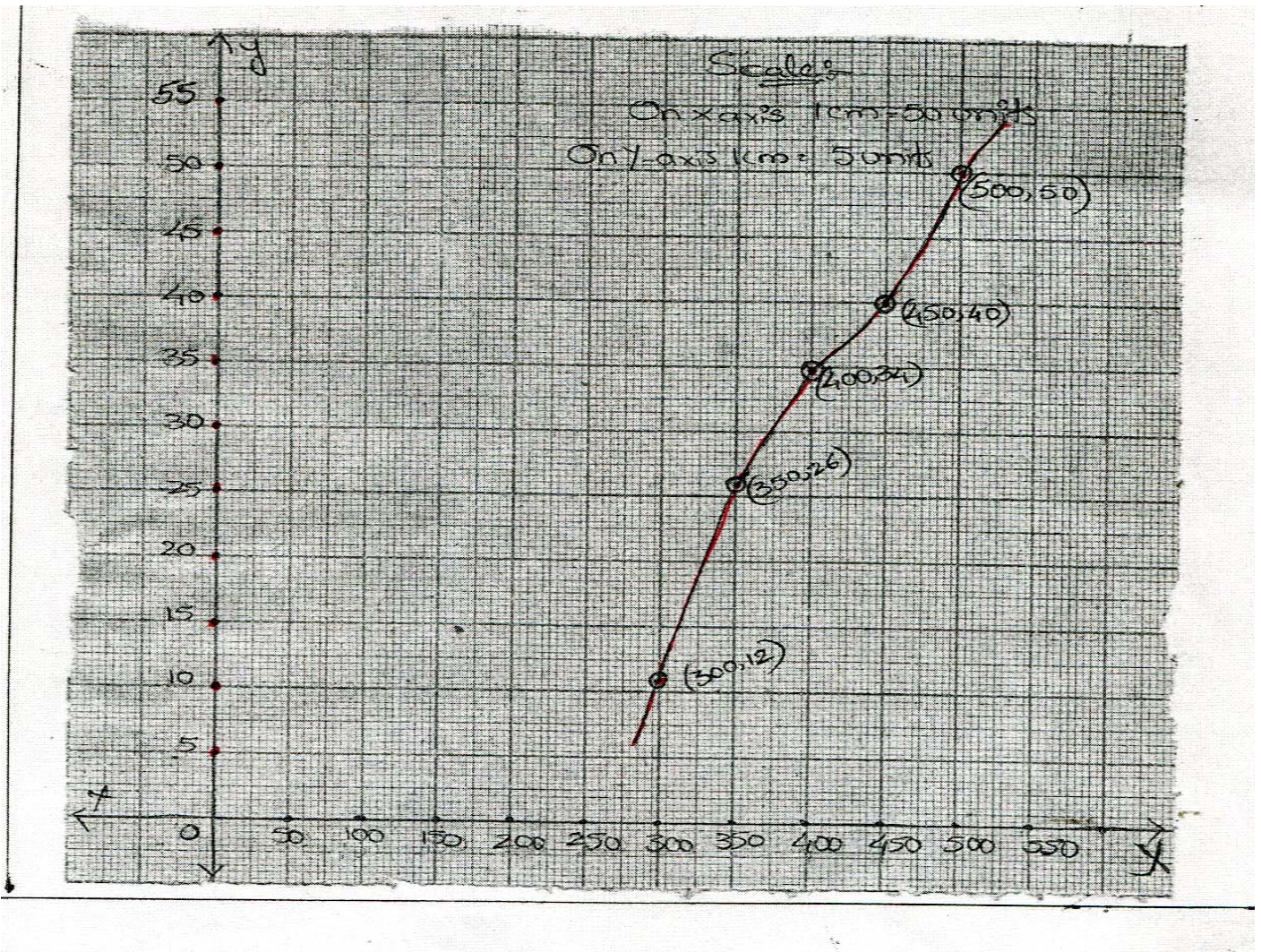

2. The following distribution shows the daily pocket allowance of children of a locality. The mean pocket allowance is Rs.98. Find the missing frequency f .

Daily pocket allowance (in Rs)	11 - 13	13 - 15	15 - 17	17 - 19	19 - 21	21 - 23	23 - 25
No. of children	7	6	9	13	f	5	4

Sol:

Daily pocket allowance	No. of children (f_i)	Mid value of classes	$u_i = \frac{x_i - a}{n}$	$f_i u_i$
11 – 13	7	12	-3	-21
13 – 15	6	14	-2	-12
15 – 17	9	16	-1	-9
17 – 19	13	18(a)	0	0
19 – 21	f	20	1	f
21 – 23	5	22	2	10
23 – 25	4	24	3	12
	$\sum f_i = f + 44$			$\sum f_i u_i = -20 + f$

$$\text{Mean } \bar{x} = a + \frac{\sum f_i u_i}{\sum f_i} \times h$$

Given mean $\bar{x} = 18$, $\sum f_i u_i = -20 + f = f + 44$, $a = 18$, $h = 2$.

$$18 = 18 + \frac{-20 + f}{f + 44} \times 2$$

$$\Rightarrow 18 = 18 + \frac{(-20 + f)}{f + 44} \times 2 \Rightarrow 0 = \frac{(-20 + f) \times 2}{f + 44}$$

$$\Rightarrow \frac{0}{2} = -20 + f$$

$$\Rightarrow 0 = -20 + f$$

$$\therefore f = 20.$$

3. **Thirty women were examined in a hospital by a doctor and their of heart beat per minute were recorded and summarised as shown. Find the mean of heart beat per minute for these women, choosing a suitable method.**

No. of heart beat/ minute	65 - 68	68 - 71	71 - 74	74 - 77	77 - 80	80 - 83	83 - 86
No. of women	2	4	3	8	7	4	2

Sol:

Let $a=75.5$

No. of heart beats/minute	No. of women f_i	Class marks (x_i)	$d_i = x_i - a$	$f_i d_i$
65 - 68	2	66.5	-9	-18
68 - 71	4	69.5	-6	-24
71 - 74	3	72.5	-3	-9
74 - 77	8	75.5= a	0	0
77 - 80	7	78.5	3	21
80 - 83	4	81.5	6	24
83 - 86	2	84.5	9	18
	$\sum f_i = 30$			$\sum f_i d_i = 12$

$$\bar{x} = a + \frac{\sum f_i d_i}{\sum f_i} = 75.5 + \frac{12}{30}$$

$$\Rightarrow 75.5 + 0.4$$

$$\Rightarrow 75.9.$$

4. In a retail market, fruit vendors were selling oranges kept in packing baskets. These baskets contained varying number of oranges. The following was the distribution of oranges.

No. of Oranges	10 – 14	15 – 19	20 – 24	25 – 29	30 – 34
No. of baskets	15	110	135	115	25

Find the mean number of oranges kept in each basket, which method of finding the mean did you choose?

Sol:

No. of oranges (C.I)	Number of baskets (f_i)	x_i	$u_i = \frac{x_i - a}{h}$ $h = 5$	$f_i u_i$
10 -14	15	12	-2	-30
15 – 19	110	17	-1	-110
20 – 24	135	22=a	0	0
25 – 29	115	27	1	115
30 – 34	25	32	2	50
	$\sum f_i = 400$			$\sum f_i u_i = 25$

Here we use step deviation method where $a = 22$, $h = 5$,

$$\bar{x} = a + \left[\frac{\sum f_i u_i}{\sum f_i} \right] \times h$$

$$= 22 + \frac{25}{400} \times 5$$

$$= 22 + 0.31$$

$$= 22.31.$$

5. The following table gives the literacy rate (in%) of 35 cities. Find the mean literacy rate.

Literacy rate in %	45 – 55	55 – 65	65 – 75	75 – 85	85 – 95
No.of cities	3	10	11	8	3

Sol:

Literacy rate	Number of cities (f_i)	Class marks (x_i)	$u_i = \frac{x_i - a}{h}$	$f_i u_i$
45 – 55	3	50	-2	-6
55 – 65	10	60	-1	-10
65 – 75	11	70a	0	0
75 – 85	8	80	1	8
85 – 95	3	90	2	6
	$\sum f_i = 35$			$\sum f_i u_i = -2$

$a = 70,$ $h = 10$

$$\therefore \bar{x} = a + \frac{\sum f_i u_i}{\sum f_i} \times h$$

$$\Rightarrow \bar{x} = 70 - \frac{2}{35} \times 10$$

$$\Rightarrow 70 - \frac{2}{35}$$

$$\Rightarrow 70 - 0.57142$$

$$\Rightarrow 69.4285 \cong 69.43\%.$$

6. The following data gives the information on the observed life times (in hours) of 225 electrical components.

Life time (in)	0 – 20	20 – 40	40 – 60	60 – 80	80 – 100	100 – 120
Frequency	10	35	52	61	33	29

Determine the modal life times of the components.

Class interval	Frequency
0 – 20	10
20 – 40	35
40 – 60	52
60 – 80	61
80 – 100	38
100 – 120	29

∴ The maximum frequency 61 is in the class 60 – 80 is the required modal class.

Modal class frequency $=f_1 = 61$.

Frequency of the class preceding the modal class $f_0 = 52$

Frequency of the class succeeding the modal class $f_2 = 38$.

Lower boundary of the model class $l = 60$

Height of the class $h = 20$

$$\begin{aligned} \text{Mode (z)} &= l + \frac{(f_1 - f_0)}{2f_1 - (f_0 + f_2)} \times h \\ &= 60 + \left[\frac{61 - 52}{2 \times 61 - (52 + 38)} \right] \times 20 \\ &\Rightarrow 60 + \left[\frac{9}{122 - 90} \right] \times 20 \end{aligned}$$

$$\Rightarrow 60 + \frac{9}{32} \times 20$$

$$= 60 + 5.625$$

$$= 65.625 \text{ hour.}$$

7. **The given distribution shows the number of runs scored by some top batsmen of the world in one day international cricket matches**

Runs	3000 – 4000	4000 – 5000	5000 – 6000	6000 – 7000	7000 – 8000	8000 – 9000	9000 – 10,000	10,000 – 11,000
No.of batsmen	4	18	9	7	6	3	1	1

Sol: Find the mode of the data.

Class interval	Frequency
3000 – 4000	4
4000 – 5000	18
5000 – 6000	9
6000 – 7000	7
7000 – 8000	6
8000 – 9000	3
9000 – 10,000	1
10,000 – 11,000	1

Maximum number of batsmen is in the class 4000 – 5000.

∴ Modal class is 4000 – 5000

Frequency of the modal class = $f_1 = 18$

Lower boundary of the modal class $l = 4000$

Frequency of the model class, preceding $f_0 = 4$

Frequency of the class succeeding the modal class $f_2 = 9$

Height of the class, $h = 1000$.

$$\text{Mode (z)} = l + \left[\frac{f_1 - f_0}{(f_1 - f_0) + (f_1 - f_2)} \right] \times h$$

$$\text{Mode (z)} = 4000 + \frac{18 - 4}{(18 - 4) + (18 - 9)} \times 1000$$

$$\Rightarrow 4000 + \frac{14}{14 + 9} \times 1000$$

$$\Rightarrow 4000 + \frac{14000}{23} = 4000 + 608.695$$

$$= 4608.69 = 4608.7 \text{ runs.}$$

8. The median of 60 observations, given below is 28.5. Find the values of x and y.

Class interval	0 – 10	10 – 20	20 – 30	30 – 40	40 – 50	50 – 60
Frequency	5	x	20	15	y	5

Sol:

Class interval	Frequency	c.f
0 -10	5	5
10 – 20	x	5 + x
20 – 30	20	25 + x
30 – 40	15	40 + x
40 – 50	y	40 + x + y
50 – 60	5	45 + x + y

$$\text{Median} = l + \left[\frac{\frac{n}{2} - cf}{f} \right] \times h$$

It is given that $\sum f = n = 60$

$$\text{So, } 45 + x + y = 60$$

$$x + y = 60 - 45 = 15$$

$$\therefore x + y = 15 \rightarrow (1)$$

The median is 28.5 which lies between 20 & 30

$$\therefore \text{Median class} = 20 - 30$$

Lower boundary of the median class 'l' = 20.

$$\frac{N}{2} = \frac{60}{2} = 30$$

Cf. cumulative frequency = 5 + x, $h = 10$

$$\text{Median} = l + \left[\frac{\frac{n}{2} - cf}{f} \right] \times h$$

$$\Rightarrow 28.5 = 20 + \frac{30 - 5 - x}{20} \times 10$$

$$\Rightarrow 28.5 = 20 + \frac{25 - x}{2}$$

$$\frac{25 - x}{2} = 28.5 - 20 = 8.5$$

$$25 - x = 2 \times 8.5$$

$$x = 25 - 17 = 8$$

Also from (1) $x + y = 15$

$$8 + y = 15$$

$$y = 7.$$

$$\therefore x = 8, y = 7.$$

9. The following data the information on the observed life times (in hours) of 400 electrical components.

Life time	1500 – 2000	2000 – 2500	2500 – 3000	3000 - 3500	3500 – 4000	4000 – 4500	4500 – 5000
Frequency	14	56	60	86	74	62	48

Class interval	Frequency
1500 – 2000	14
2000 – 2500	70
2500 – 3000	130
3000 – 3500	261
3500 – 4000	290
4000 – 4500	352
4500 – 5000	400

$$n = 400$$

$$l = 3000$$

$$\frac{n}{2} = \frac{400}{2} = 200$$

$$cf = 130$$

$$f = 86$$

$$h = 500$$

$$\text{Median} = l + \left[\frac{\frac{n}{2} - cf}{f} \right] \times h$$

$$\begin{aligned}
 &= 3000 + \frac{(200-130)}{86} \times 500 \\
 &= 3000 + \frac{70 \times 500}{86} \\
 &= 3000 + \frac{35000}{86} \\
 &= 3000 + 406.97 \\
 &= 3406.98
 \end{aligned}$$

Life time median of the bulb = 3406.98 hr.

10. Draw “OGIVE CURVE” of the following frequency distribution table.

Classes	0 – 20	20 – 40	40 – 60	60 – 80	80 – 100	100 – 120
Frequency	9	16	24	15	4	2

Class	Frequency	L.C.F	U.B
0 – 20	9	9	20
20 – 40	16	9 + 16 = 25	40
40 – 60	24	25 + 24 = 49	60
60 – 80	15	49 + 15 = 64	80
80 – 100	4	64 + 4 = 68	100
100 – 120	2	68 + 2 = 70	120

Let us draw a graph by considering upper boundary values on x – axis and L.C.F values on y-axis. The points to be located in the graph are

(20, 9), (40, 25), (60, 49), (80, 64), (100, 68), (120, 70).

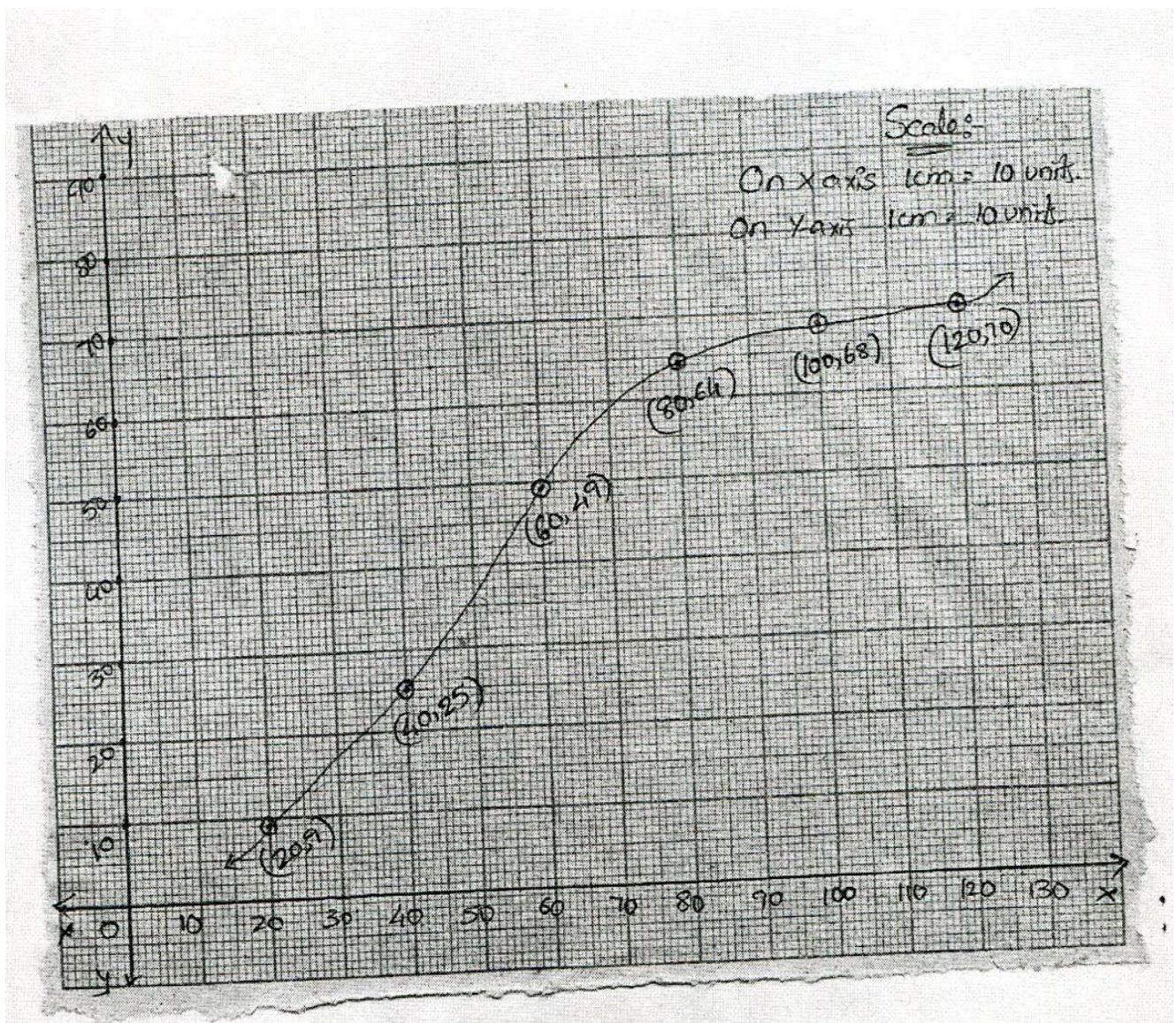

11. The following distribution gives the daily income of 50 workers of a factory.

Daily income	250 – 300	300 – 350	350 – 400	400 – 450	450 – 500
No. of workers	12	14	8	6	10

Convert the distribution above to a less than type cumulative frequency distribution, draw its ogive.

Class interval	f	c.f	Point
Less than 300	12	12	(300, 12)
Less than 350	14	26	(350, 26)
Less than 400	8	34	(400, 34)
Less than 450	6	40	(450, 40)
Less than 500	10	50	(500, 50)

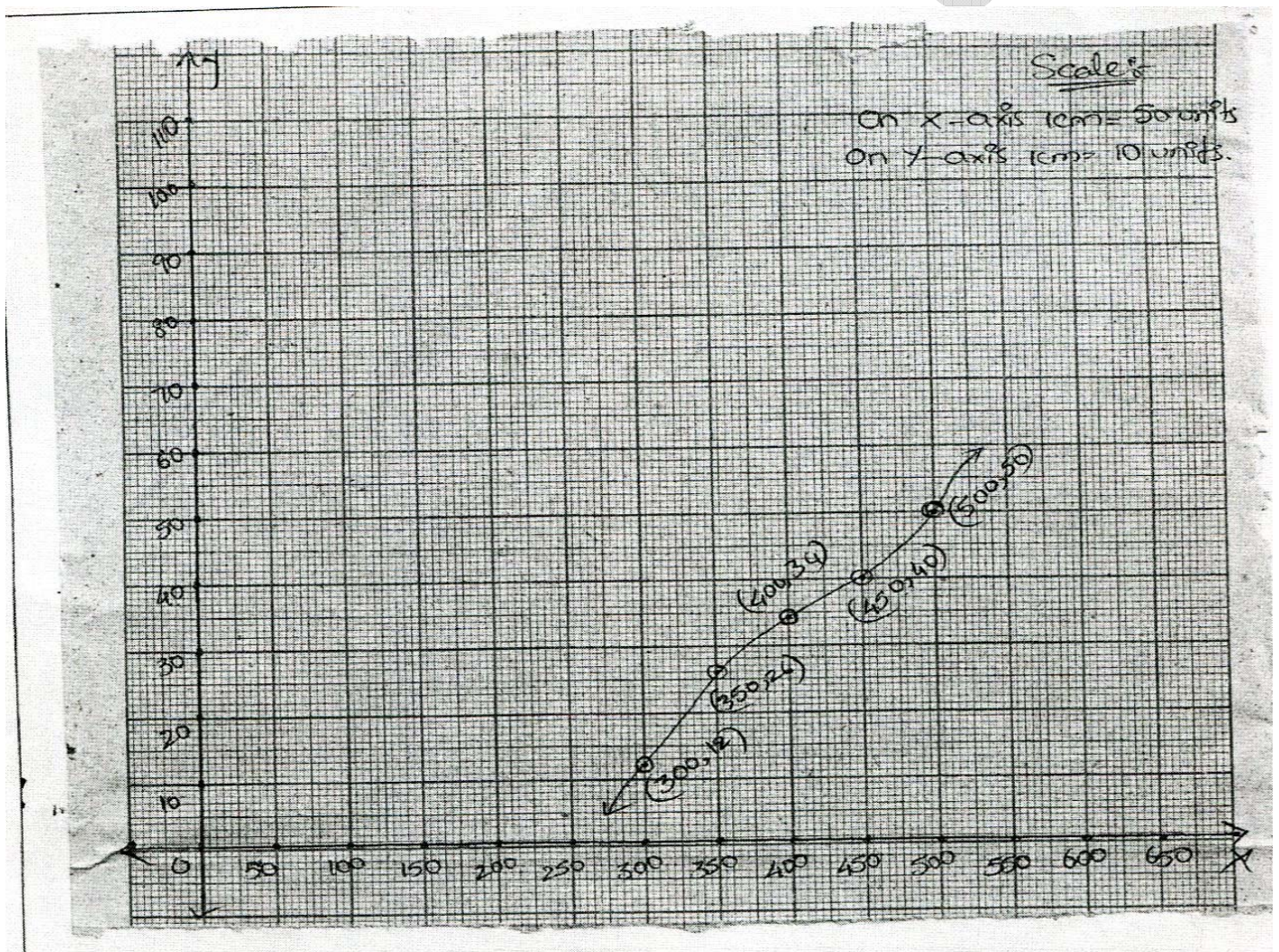

12. During the medical checkup of 35 students of a class, their weight were recorded as fallows?

Weight (in kg)	No. of students
Less than 38	0
Less than 40	3
Less than 42	5
Less than 44	9
Less than 46	14
Less than 48	28
Less than 50	32
Less than 52	35

Draw a less than type ogive for the given data. Hence obtain the median weight from the graph and verify the result by using the formula.

Given: Upper limits of the classes and less than cumulative frequencies. Therefore required points are (38, 0), (40, 3), (44, 9), (46, 14), (48, 28), (50, 32), & (52, 35).

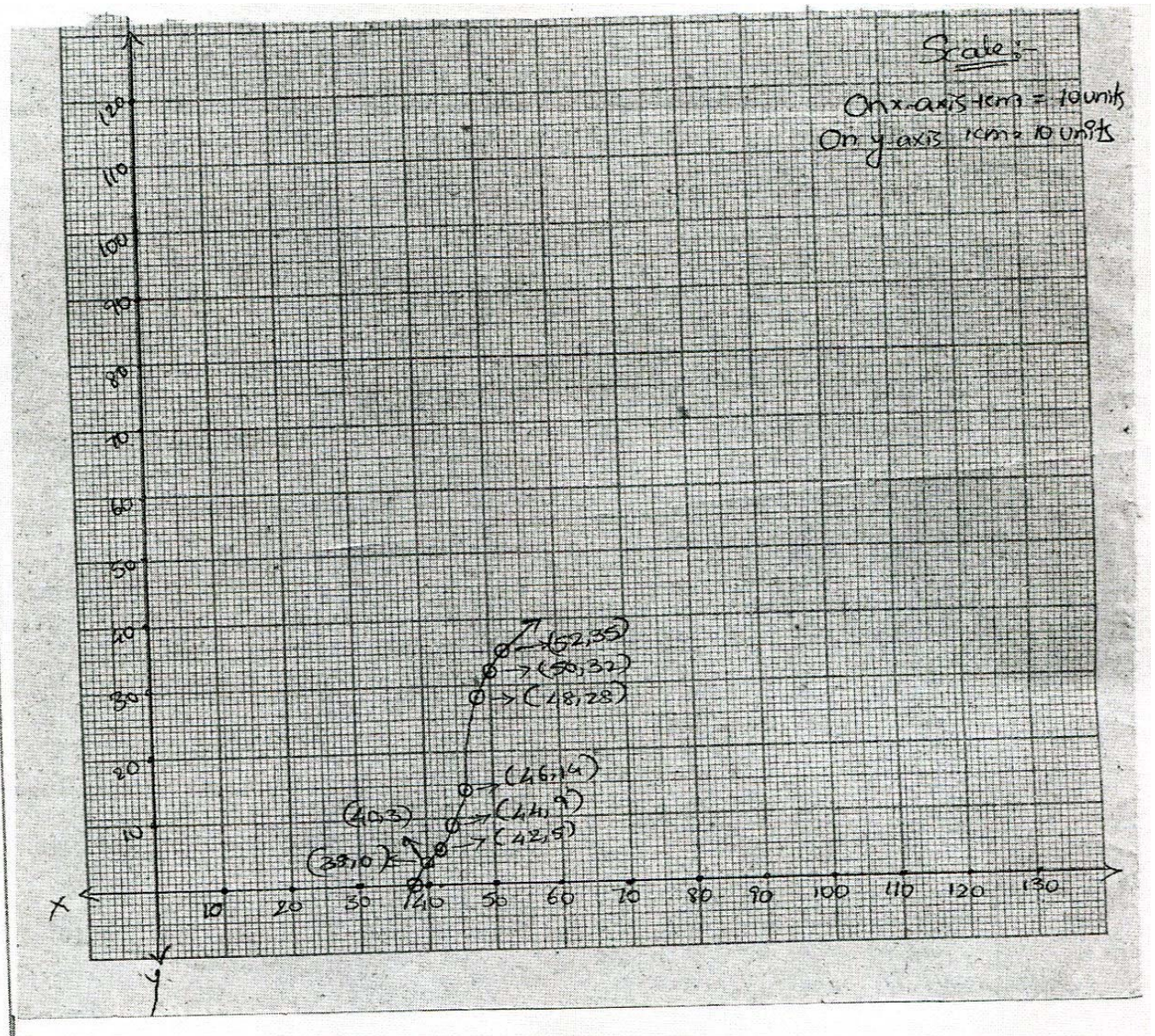

13. The following table gives production yield per hectare of wheat of 100 farms of a village.

Production yield	50 – 55	55 – 60	60 – 65	65 – 70	70 – 75	75 – 80
No. of farmers	2	8	12	24	38	16

Change the distribution to a more than type distribution & draw its ogive. The given data is to be more than frequency distribution type.

Sol:

Production yield(Qui /Hec)	More than cf	No. of farmers	Points
More than 50	100	2	(50, 100)
More than 55	98	8	(55, 98)
More than 60	90	12	(60, 90)
More than 65	78	24	(65, 78)
More than 70	54	38	(70, 54)
More than 75	16	16	(75, 16)

A graph is plotted by taking the lower limits on the x – axis and respective of y –axis.

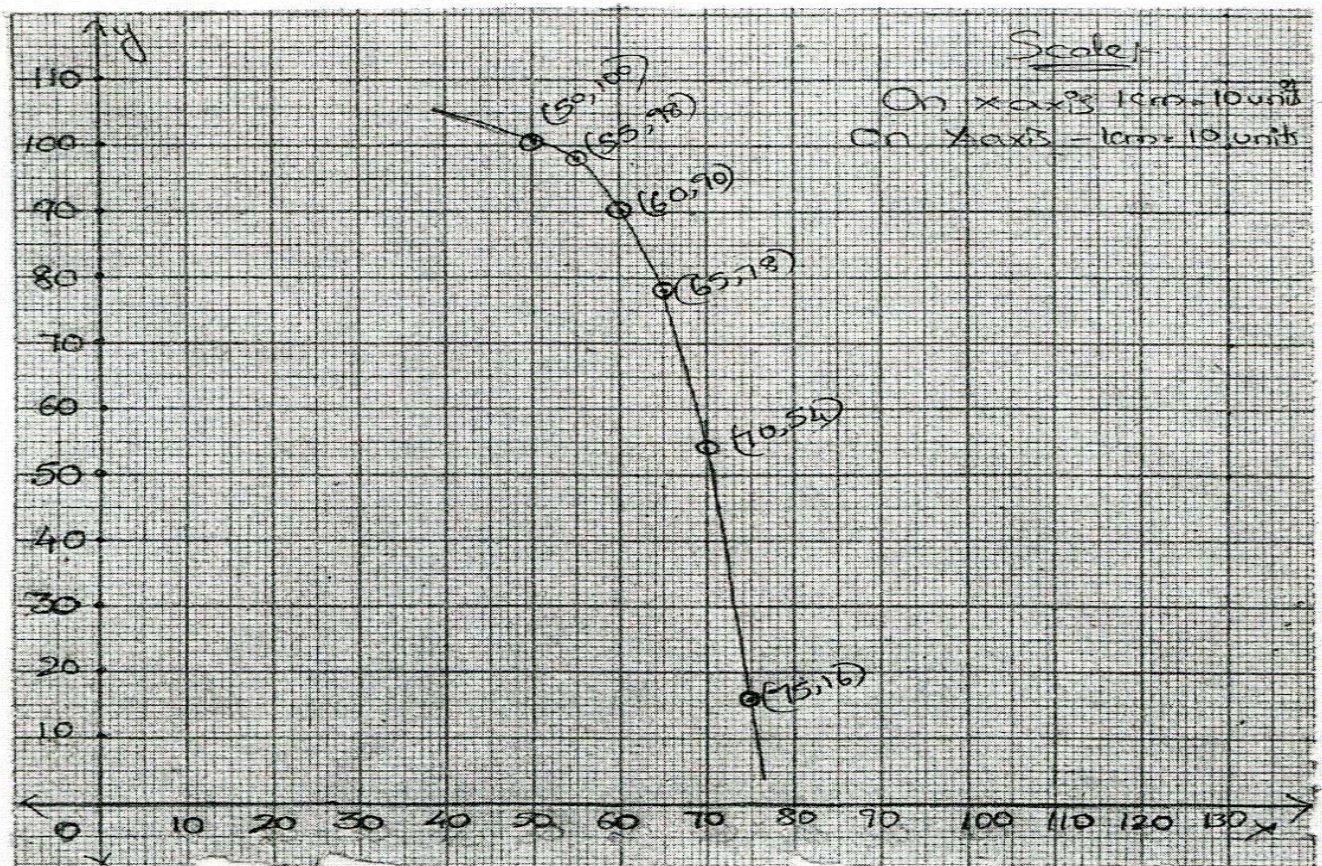

9. Median of 17, 31, 12, 27, 15, 19 and 23 is _____ []
A) 16 B) 20 C) 19 D) None
10. A.M of 12, 3..... 10 is _____ []
A) 3.2 B) 6.1 C) 3.5 D) 5.3
11. Range of 1, 2, 3, 4,..... n is _____ []
A) n B) n – 1 C) n^2 D) $\frac{n}{2}$
12. For the given data with 50 observations “the less than ogive” and the more than ogive intersect at (15.5, 20). The median of the data is _____ []
A) 11.5 B) 14.5 C) 15.5 D) 12
13. The mean of first n odd natural numbers is $\frac{n^2}{81}$ then n = _____ []
A) 81 B) 18 C) 27 D) 54
14. A.M of 1, 2, 3,..... n is _____ []
A) $\frac{n}{2}$ B) $\frac{n+1}{2}$ C) $\frac{n-1}{2}$ D) None
15. If the mean of 6, 7, x, 8, y, 14 is 9, then x = _____ []
A) $x + y = 21$ B) $x + y = 19$
C) $x - y = 19$ D) $x - y = 21$

KEY

- 1) B; 2) A; 3) A; 4) A; 5) B;
6) C; 7) B; 8) D; 9) C; 10) D;
11) B; 12) C; 13) A; 14) B; 15) B.

Fill in the Blanks

1. The A.M of 30 students is 42. Among them two get zero marks then A.M of remaining students is _____

2.

Marks	10	20	30
No. of students	5	9	3

From the above data the value of median is _____

3. Data having one mode is called _____

4. A.M of 1, 2, 3 _____ n is _____

5. sum of all deviations taken from A.M is _____

6. Mode of A, B, C, D,..... Z is _____

7. Mean of first 5 prime numbers is _____

8. The observation of an ungrouped data in their ascending order are 12, 15, x, 19, 15 if the median of the data is 18 then x = _____

9. AM of a -2, a, a + 2 is _____

10. Median of 1, 2, 4, 5 is _____

11. Class mark of the class x – y is _____

12. L.C.F curve is drawn by using _____ and the corresponding cumulative frequency

13. The modal class for the following distribution is _____

x	Below 10	Below 20	Below 30	Below 40	Below 50	Below 60
f	-3	12	27	57	75	80

14. If the A.M of x, x + 3, x + 6, x + 9 and x + 12 is 10 then x = _____

15. If 35 is removed from the data 30, 34, 35, 36, 37, 38, 39, 40 then the median increases by _____

16. Range of first 10 whole numbers is _____
17. Construction of cumulative frequency table is useful in determining the _____
18. Exactly middle value of data is called _____
19. In the formula of mode

$$\text{Mode} = l + \frac{f_1 - f_0}{2f - f_0 - f_2} \times h, f_0 \text{ represents } \underline{\hspace{2cm}}$$

20. Median = $l + \frac{\frac{n}{2} - cf}{f} \times n$; 'l' represents _____

21. The term 'ogive' is derived from []

A) ogee B) ogie C) Ogeve D) Ogel

22. Range of the data 15, 26, 39, 41, 11, 18, 7, 9 is _____ []

A) 41 B) 39 C) 32 D) 34

23. The mean of first 'n' natural number is _____ []

A) $\frac{2n+1}{2}$ B) $\frac{2n-1}{2}$ C) $\frac{n+1}{2}$ D) $\frac{n}{2}$

24. Median of first 'n' natural number is _____ []

A) n B) $\frac{n}{2}$ C) $\frac{n}{2} + 1$ D) $\frac{n+1}{2}$

Key:

- 1) 42; 2) 9; 3) unimodal data; 4) $\frac{n+1}{2}$; 5) 0; 6) no mode; 7) 5.6;
- 8) 18; 9) a; 10) 3; 11) $\frac{x+y}{2}$; 12) upper boundary; 13) 30 – 40; 14) 4; 15) 0.5;
- 16) 9; 17) Median; 18) median; 19) frequency of preceding of preceding model class;
- 20) lower limit of median; 21) A; 22) C; 23) C; 24) D.

Chapter – 3

Polynomials

Polynomial: Let x be a variable, n be a positive integer and a_1, a_2, \dots, a_n be constants (real numbers).

Then

$f(x) = a_n x^n + a_{n-1} x^{n-1} + \dots + a_1 x + a_0$ is called a **polynomial** in variable x .

In the polynomial $f(x) = a_n x^n + a_{n-1} x^{n-1} + \dots + a_1 x + a_0$

$a_n x^n, a_{n-1} x^{n-1}, \dots, a_1 x$ and a_0 are known as the terms of the polynomial and $a_n, a_{n-1}, \dots, a_1, a_0$ are their coefficients.

Ex: $f(x) = 2x + 3$ is a polynomial in variable x .

$g(y) = 2y^2 - 7y + 4$ is a polynomial in variable y .

Note: The expressions like $2x^2 - 3\sqrt{x} + 5, \frac{1}{x^2 - 2x + 5}, 2x^3 - \frac{3}{x} + 4$ are not polynomials.

Degree of a Polynomial: The exponent of the highest degree term in a polynomial is known as its degree.

In other words, the highest power of x in a polynomial $f(x)$ is called the degree of the polynomial $f(x)$.

Ex: $f(x) = 5x^3 - 4x^2 + 3x - 4$ is a polynomial in the variable x of degree '3'.

Constant Polynomial: A polynomial of degree zero is called a Constant Polynomial.

Ex: $f(x) = 7, p(t) = 1$

Linear Polynomial: A polynomial of degree 1 is called a linear polynomial.

Ex: $p(x) = 4x - 3$; $f(t) = \sqrt{3}t + 5$

Quadratic Polynomial: Polynomial of degree 2 is called **Quadratic Polynomial**.

Ex: $f(x) = 2x^2 + 3x - \frac{1}{2}$

$$g(x) = ax^2 + bx + c, \quad a \neq 0$$

Note: A quadratic polynomial may be a monomial or a binomial or trinomial.

Ex: $f(x) = \frac{2}{3}x^2$ is a monomial, $g(x) = 5x^2 - 3$ is a binomial and $h(x) = 3x^2 - 2x + 5$

is a trinomial.

Cubic Polynomial: A polynomial of degree 3 is called a **cubic polynomial**.

Ex: $f(x) = \frac{2}{3}x^3 - \frac{1}{7}x^2 + \frac{4}{5}x + \frac{1}{4}$

Polynomial of nth Degree: $f(x) = a_nx^n + a_{n-1}x^{n-1} + a_{n-2}x^{n-2} + \dots + a_1x + a_0$ is a polynomial of nth degree, where $a_n, a_{n-1}, \dots, a_1, a_0$ are real coefficients and $a_n \neq 0$.

Value of a Polynomial: The value of a polynomial $P(x)$ at $x = k$, where k is a real number, is denoted by $P(k)$ and is obtained by putting k for x in the polynomial.

Ex: Value of the polynomial $f(x) = x^2 - 2x - 3$ at $x = 2$ is $f(2) = 2^2 - 2(2) - 3 = -3$.

Zeroes of a Polynomial: A real number k is said to be a zero of the polynomial $f(x)$ if $f(k) = 0$

Ex: Zeroes of a polynomial $f(x) = x^2 - x - 6$ are -2 and 3 ,

Because $f(-2) = (-2)^2 - (-2) - 6 = 0$ and $f(3) = 3^2 - 3 - 6 = 0$

Zero of the linear polynomial $ax + b, a \neq 0$ is $\frac{-b}{a}$

Graph of a Linear Polynomial:

- i) Graph of a linear polynomial $ax + b$, $a \neq 0$ is a straight line.
- ii) A linear polynomial $ax + b$, $a \neq 0$ has exactly one zero, namely X co-ordinate of the point where the graph of $y = ax + b$ intersects the X-axis.
- iii) The line represented by $y = ax + b$ crosses the X-axis at exactly one point, namely $\left(-\frac{b}{a}, 0\right)$.

Graph of a Quadratic Polynomial:

For any quadratic polynomial $ax^2 + bx + c$, $a \neq 0$, the graph of the corresponding equation $y = ax^2 + bx + c$ either opens upwards like \cup or opens downwards like \cap . This depends on whether $a > 0$ or $a < 0$. The shape of these curves are called **parabolas**.

The zeroes of a quadratic polynomial $ax^2 + bx + c$, $a \neq 0$ are precisely the X-coordinates of the points where the parabola representing $y = ax^2 + bx + c$ intersects the X-axis.

- A quadratic polynomial can have at most 2 zeroes.
- A cubic polynomial can have at most '3' zeroes.
- A constant polynomial has no zeroes.
- A polynomial $f(x)$ of degree n , the graph of $y = f(x)$ intersects the X-axis at most 'n' points.

Therefore, a polynomial $f(x)$ of degree n has at most 'n' zeroes.

Relationship between Zeroes and Coefficients of a Polynomial:

- i) The zero of the linear polynomial $ax + b$, $a \neq 0$ is $-\frac{b}{a}$.
- ii) If α, β are the zeroes of the quadratic polynomial $ax^2 + bx + c$, $a \neq 0$ then

$$\text{Sum of the zeroes} = \alpha + \beta = -\frac{b}{a} = \frac{-(\text{Coefficient of } x)}{\text{Coefficient of } x^2}$$

$$\text{Product of the zeroes} = \alpha\beta = \frac{c}{a} = \frac{\text{Constant term}}{\text{Coefficient of } x^2}$$

iii) If α, β, γ are the zeroes of the cubic polynomial $ax^3 + bx^2 + cx + d, a \neq 0$ then

$$\alpha + \beta + \gamma = -\frac{b}{a} = \frac{-(\text{Coefficient of } x^2)}{\text{Coefficient of } x^3}$$

$$\alpha\beta + \beta\gamma + \gamma\alpha = \frac{c}{a} = \frac{\text{Coefficient of } x}{\text{Coefficient of } x^3}$$

$$\alpha.\beta.\gamma = -\frac{d}{a} = \frac{-(\text{constant term})}{\text{coefficient of } x^3}$$

- A quadratic polynomial with zeroes α and β is given by

$$k\{x^2 - (\alpha + \beta)x + \alpha\beta\}, \text{ where } k (\neq 0) \text{ is real.}$$

- A cubic polynomial with zeroes α, β and γ is given by

$$k\{x^3 - (\alpha + \beta + \gamma)x^2 + (\alpha\beta + \beta\gamma + \alpha\gamma)x - \alpha\beta\gamma\} \text{ where } k (\neq 0) \text{ is real.}$$

Division Algorithm for Polynomials: Let $p(x)$ and $g(x)$ be any two polynomials where $g(x) \neq 0$. Then on dividing $p(x)$ by $g(x)$, we can find two polynomials $q(x)$ and $r(x)$ such that

$$p(x) = g(x) \times q(x) + r(x), \text{ where either } r(x) = 0$$

Or degree of $r(x) <$ degree of $g(x)$.

This result is known as "Division Algorithm for polynomials".

- Note:**
- i) If $r(x) = 0$, then $g(x)$ will be a factor of $p(x)$.
 - ii) If a real number k is a zero of the polynomial $p(x)$, then $(x - k)$ will be a factor of $p(x)$.
 - iii) If $q(x)$ is linear polynomial then $r(x) = \text{Constant}$
 - iv) If $p(x)$ is divided by $(x - a)$, then the remainder is $p(a)$.
 - v) If degree of $q(x) = 1$, then degree of $p(x) = 1 + \text{degree of } g(x)$.

Essay Question (5 marks)

(1) Draw the graph of $y = 2x - 5$ and find the point of intersection on x – axis. Is the X – Coordinates of these points also the zero the polynomial.

(Visualization and Representation)

Solution: $Y = 2x - 5$

The following table lists the values of y corresponding to different values of x .

X	-2	-1	0	1	2	3	4
Y	-9	-7	-5	-3	-1	1	3

The points (-2, -9), (-1, -7), (0, -5), (1, -3), (2, -1), (3, 1) and (4, 3) are plotted on the graph paper on a suitable scale. A line is drawn passing through these points to obtain the graph of the given linear equation.

The graph cuts the x- axis at $p(\frac{5}{2}, 0)$

This is also the zero of the liner equation

$$Y = 2x - 5$$

Because To find the zero of $y = 2x - 5$,

$$2x - 5 = 0 \Rightarrow 2x = 5 \Rightarrow X = \frac{5}{2}$$

\therefore The zero of the liner equation is $\frac{5}{2}$

Model Question: Draw the graph of $y = 2x+3$.

(i) $y = 2x - 5$ Graph: Scale:

X-axis 1cm = 1unit

Y-axis 1cm = 1unit

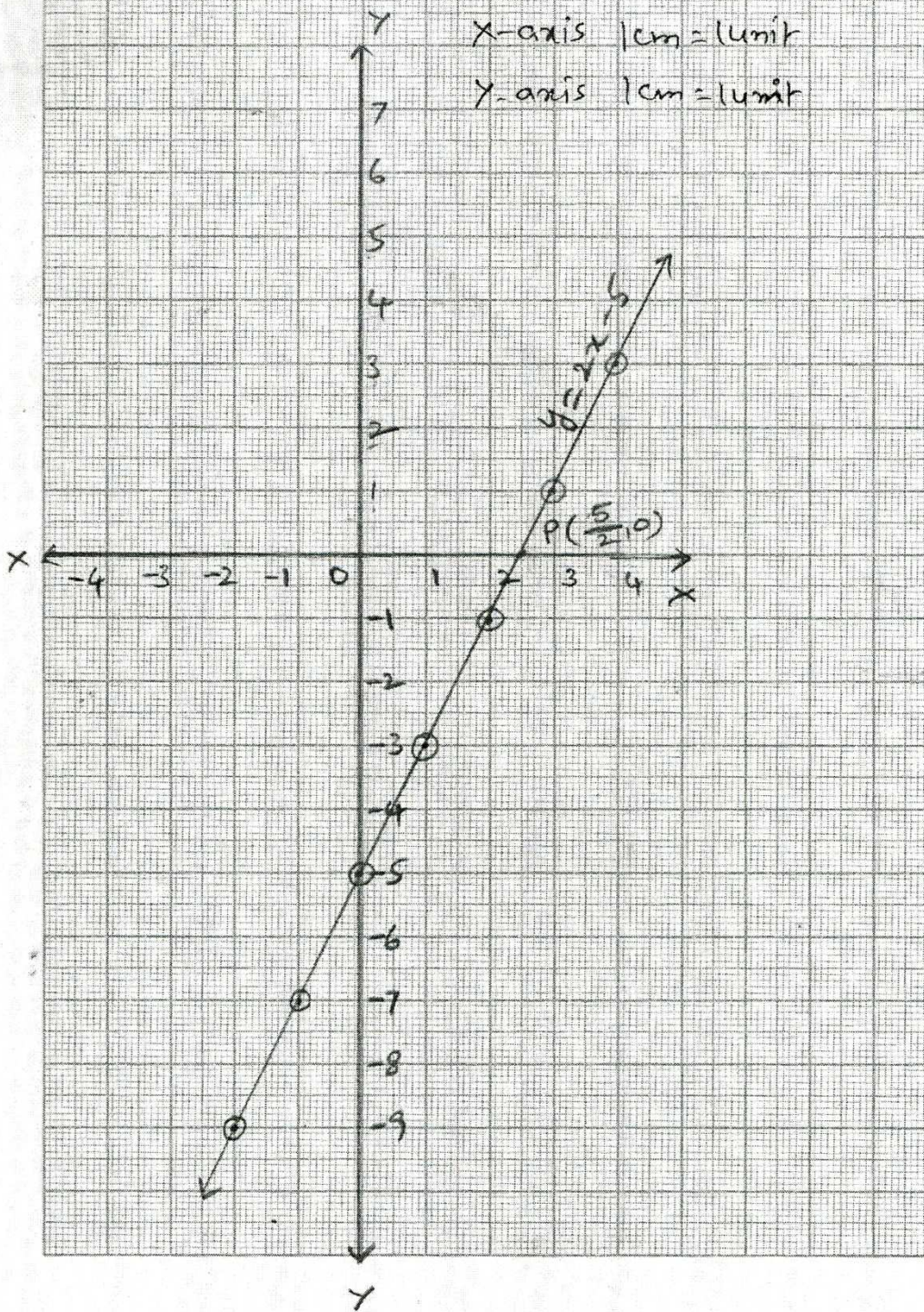

(2) Draw the graph of the polynomial $f(x) = x^2 - 2x - 8$ and find zeroes. Verify the zeroes of the polynomial.

Solution: Let $y = x^2 - 2x - 8$

The following table given the values of y for various values of x .

X	-3	-2	-1	0	1	2	3	4	5
Y = $x^2 - 2x - 8$	7	0	-5	-8	-9	-8	-5	0	7
(x, y)	(-3, 7)	(-2, 0)	(-1, -5)	(0, -8)	(1, -9)	(2, -8)	(3, -5)	(4, 0)	(5, 7)

The Points $(-3, 7)$, $(-2, 0)$, $(-1, -5)$, $(0, -8)$, $(1, -9)$, $(2, -8)$, $(3, -5)$, $(4, 0)$ and $(5, 7)$ are plotted on the graph paper on the suitable scale and drawn a smooth free hand curve passing through these points.

The curve thus obtained represents the graph of the polynomial $y = x^2 - 2x - 8$. This is called a parabola.

The curve cuts the x – axis at $(-2, 0)$ and $(4, 0)$.

The x – coordinates of these points are zeroes of the polynomial $y = x^2 - 2x - 8$. Thus -2 and 4 are the zeroes.

Verification: To find zeroes of $x^2 - 2x - 8$

$$x^2 - 2x - 8 \Rightarrow x^2 - 4x + 2x - 8 = 0$$

$$x(x-4) + 2(x-4) = 0$$

$$(x-4)(x+2) = 0$$

$$x - 4 = 0 \text{ or } x + 2 = 0 \Rightarrow x = 4 \text{ or } -2 \text{ are the zeroes.}$$

② $y = x^2 - 2x - 8$ graph

Scale ⁰ ③ ⑧

X-axis 1cm = 1unit

Y-axis 1cm = 1unit

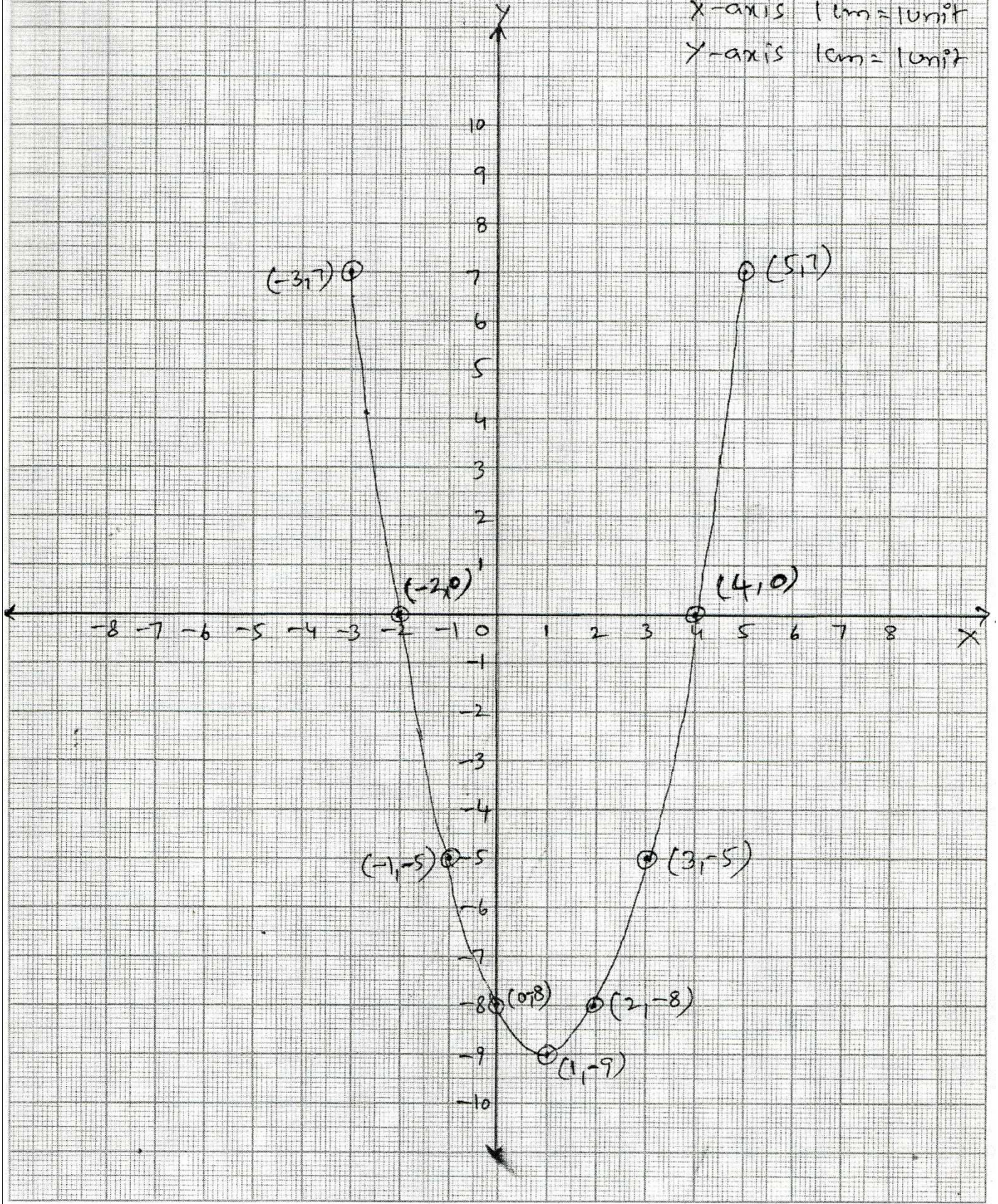

(3) Draw the graph of $f(x) = 3-2x-x^2$ and find zeroes .Find zeroes. Verify the zeroes of the polynomial.

Solution: Let $y = 3-2x-x^2$

The following table given of values of y for various values of x.

X	-4	-3	-2	-1	0	1	2	3
Y=3-2x-x²	-5	0	3	4	3	0	-5	-12
(x ,y)	(-4,-5)	(-3,0)	(-2,3)	(-1,4)	(0,3)	(1,0)	(2,-5)	(3,-12)

The points (-4,5), (-3,0), (-2,3), (-1,4), (0,3), (1,0), (2,-5) and (3,-12) are plotted on the graph paper on a suitable scale and drawn a smooth free hand curve passing through these points.

The curve thus obtained represent s the graph of the polynomial $y = 3-2x-x^2$. This called parabola opening downward.

The curve cuts the x- axis at (-3, 0) and (1,0) .

The x – coordinates of these points are zeroes of the polynomial. Thus the zeroes are -3, 1

Verification:

To find zeroes of $y = 3-2x-x^2$,

$$3-2x-x^2 = -x^2 -2x +3 = 0$$

$$-x^2 -3x+x+3 = 0$$

$$-x(x+3)+1(x+3)=0$$

$$(x+3)(1-x) = 0$$

$$x+3 = 0 \text{ or } 1-x = 0 \Rightarrow x = -3 \text{ or } 1 \text{ are the zeroes.}$$

③ $y = 3 - 2x - x^2$ graph

Scale

x-axis 1cm = 1unit

y-axis 1cm = 1unit

3
10

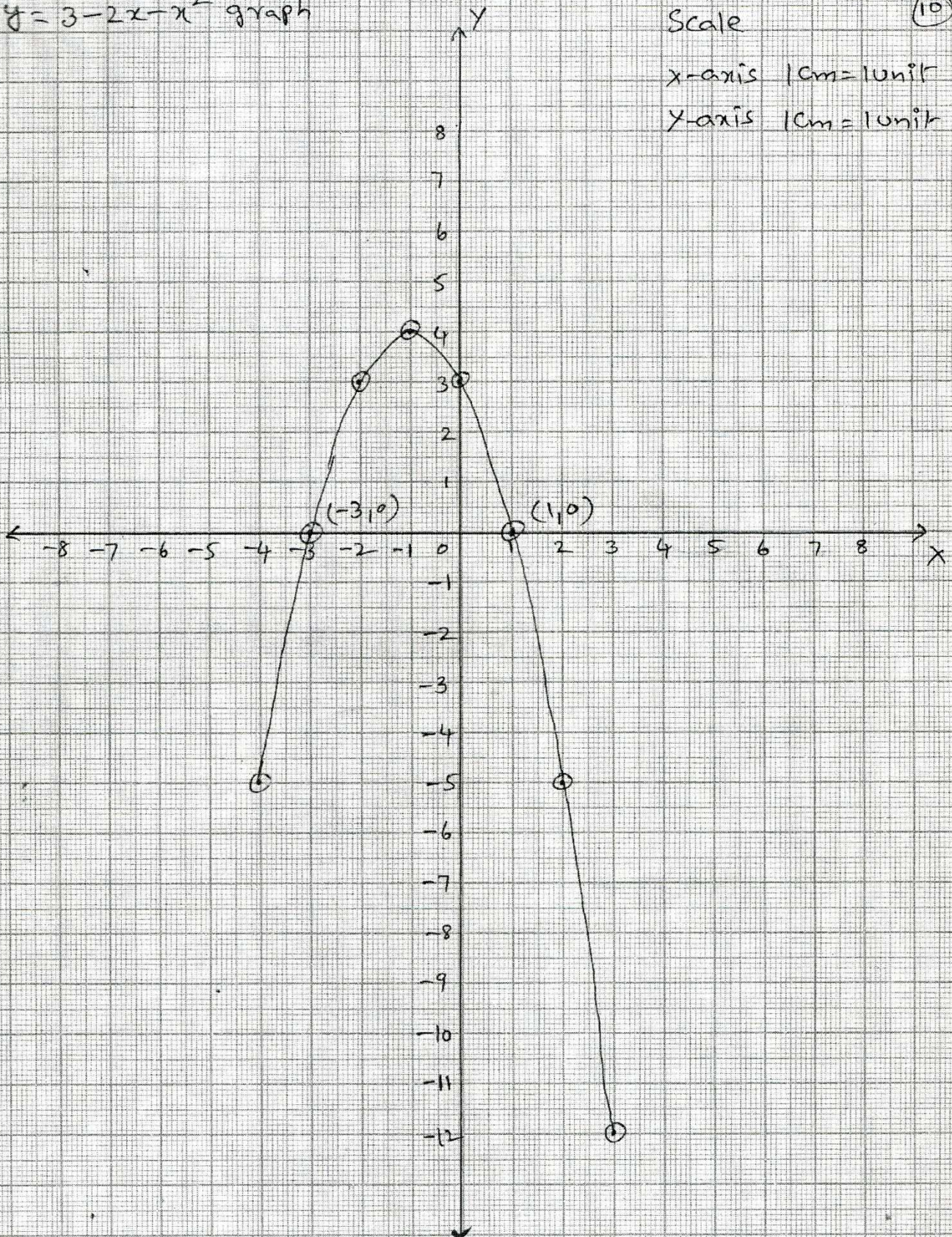

(4) Draw the graph of $y = x^2 - 6x + 9$ and find zeroes verify the zeroes of the polynomial.

Solution: Let $y = x^2 - 6x + 9$

The following table gives the values of y for various values of x

X	-2	-1	0	1	2	3	4	5	6
$y = x^2 - 6x + 9$	25	16	9	4	1	0	1	4	9
(x, y)	(-2,25)	(-1,16)	(0,9)	(1,4)	(2,1)	(3,0)	(4,1)	(5,4)	(6,9)

The point (-2,25), (-1,16), (0,9), (1,4), (2,1), (3,0), (4,1), (5,4) and (6,9) are plotted on the graph paper on a suitable scale and drawn a smooth free hand curve passing through these points.

The curve thus obtained represents the graph of the polynomial $y = x^2 - 6x + 9$.

The curve touches x-axis at one point (3,0). The x- coordinate of this point is the zero of the polynomial $y = x^2 - 6x + 9$. Thus the zero is 3.

Verification:

To find zeros of $x^2 - 6x + 9$

$$x^2 - 6x + 9 = 0 \Rightarrow (x-3)^2 = 0$$

$$x - 3 = 0 \text{ or } x - 3 = 0$$

$x = 3$ is the zero.

④ $y = x^2 - 6x + 9$ graph

Scale

X-axis 1cm = 1unit

Y-axis 1cm = 2units

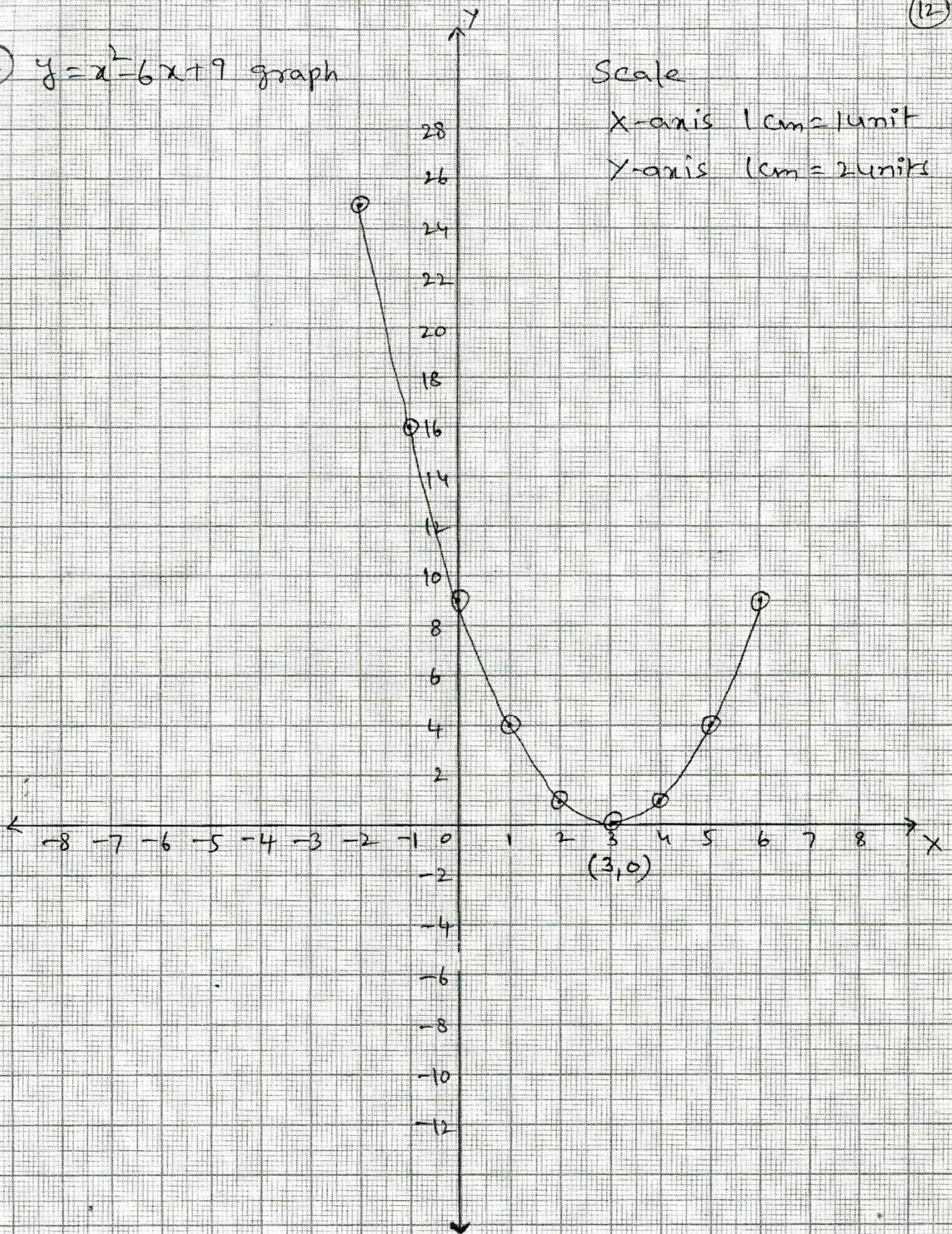

(5) Draw the graph of the polynomial $y = x^2 - 4x + 5$ and find zeroes . Verify the zeroes of the polynomial.

Solution: $y = x^2 - 4x + 5$

The following table gives the values of y for various values of x .

X	-3	-2	-1	0	1	2	3	4
$y = x^2 - 4x + 5$	26	17	10	5	2	1	2	5
(x, y)	(-3,26)	(-2,17)	(-1,10)	(0,5)	(1,2)	(2,1)	(3,2)	(4,5)

The point (-3,26), (-2,17), (-1,10), (0,5), (1,2), (2,1), (3,2) and (4,5) are plotted on the graph paper on a suitable scale and drawn a smooth free hand curve passing through these points.

The curve thus obtained represents the graph of the polynomial $y = x^2 - 4x + 5$

The curve does not intersect the x-axis.

∴ There are no zeroes of the polynomial $y = x^2 - 4x + 5$

5) $y = x^2 - 4x + 5$ graph

3
14

Scale

X-axis 1cm = 1unit

Y-axis 1cm = 2units

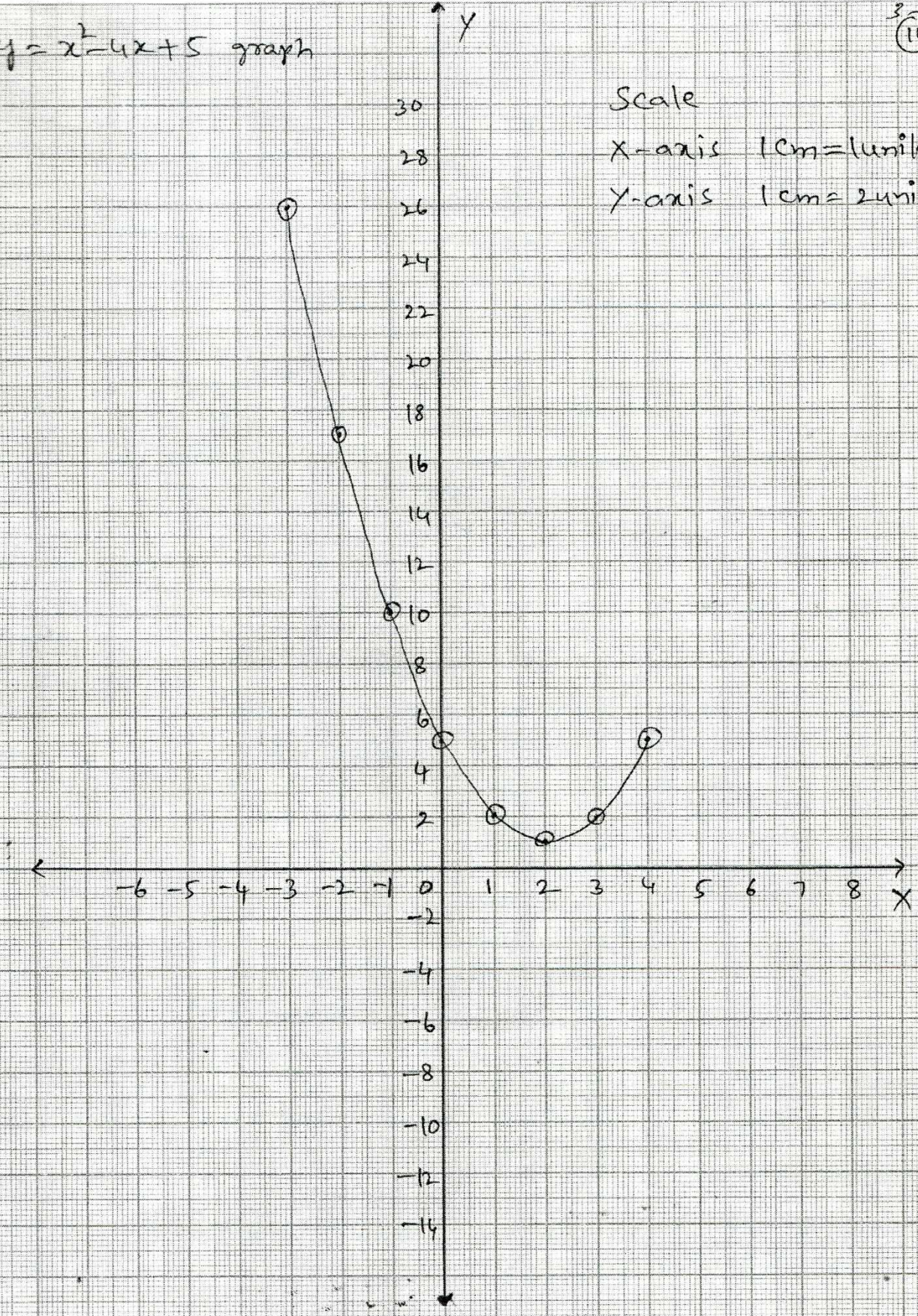

(6) Draw the graph of the polynomial $f(x) = x^3 - 4x$ and find zeroes. Verify the zeros of the polynomial.

Solution: Let $y = x^3 - 4x$

The following table gives the values of y for various of x .

X	-3	-2	-1	0	1	2	3
$y = x^3 - 4x$	-15	0	3	0	-3	0	15
(x, y)	(-3, -15)	(-2,0)	(-1,3)	(0,0)	(1,-3)	(2,0)	(3,15)

The points (-3,15), (-2,0), (-1,3), (0,0), (1,-3), (2,0) and (3,15) are plotted on the graph paper on a suitable scale and drawn a smooth free hand curve passing through these points.

The curve thus obtained represents the graph of the polynomial $y = x^3 - 4x$.

The curve touches x-axis at (-2,0), (0,0), (2,0). The x- coordinate of this points are the zero of the polynomial $y = x^3 - 4x$. Thus -2, 0, 2, are the zeroes of the polynomial.

Verification:

To find zeroes of $x^3 - 4x$

$$x^3 - 4x = 0 \Rightarrow x(x^2 - 4) = 0$$

$$\Rightarrow x(x-2)(x+2) = 0$$

$$\Rightarrow x = 0 \text{ or } x - 2 = 0 \text{ or } x + 2 = 0$$

$$\Rightarrow x = 0 \text{ or } 2 \text{ or } -2 \text{ are the zeroes.}$$

6) $y = x^3 - 4x$ graph

16

Scales:
X-axis 1cm = 1unit
Y-axis 1cm = 2units

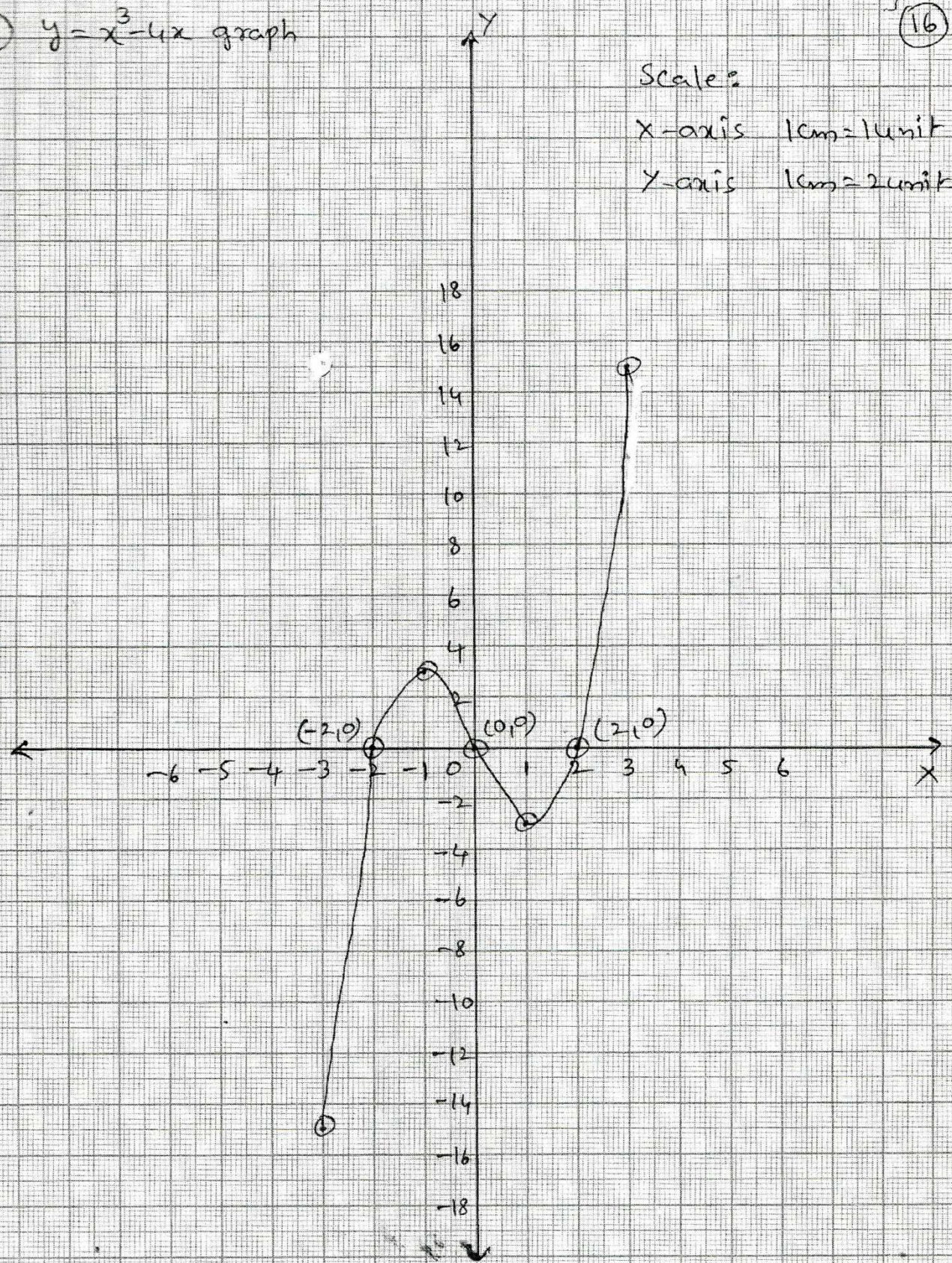

Essay Questions

(1) Find the zeroes of the following quadratic polynomials and verify the relationship between the zeroes and the coefficients.

(I). x^2-2x-8

(ii). $6x^2-3-7x$

Solution: (I) Given polynomial x^2-2x-8

$$= x^2-4x+2x-8$$

$$= x(x-4)+2(x-4)$$

$$= (x-4)(x+2)$$

For zeroes of the polynomial, the value of $x^2-2x-8 = 0$

$$(x-4)(x+2) = 0$$

$$x-4 = 0 \text{ or } x+2 = 0$$

$$x = 4 \text{ or } x = -2$$

\therefore The zeroes of x^2-2x-8 are -2 and 4.

We observe that

$$\text{Sum of the zeroes} = -2+4 = 2 = -(-2)$$

$$= \frac{-(\text{coefficient of } x)}{\text{coefficient of } x^2}$$

$$\text{Product of the zeroes} = (-2) \times 4 = -8 = \frac{8}{1} = \frac{\text{constant term}}{\text{coefficient of } x^2}$$

(ii) . Given polynomial $6x^2-3-7x$

$$= 6x^2-7x-3$$

$$= 6x^2 -9x+2x-3$$

$$= 3x(2x-3)+1(2x-3)$$

$$= (2x-3) (3x+1)$$

For zeroes of the polynomial , the value of $6x^2-3-7x = 0$ are

$$(2x-3) (3x+1) = 0$$

$$2x - 3 = 0 \quad \text{or} \quad 3x+1 = 0$$

$$x = \frac{3}{2} \quad \text{or} \quad x = -\frac{1}{3}$$

\therefore The zeroes of $6x^2-3-7x = 0$ are $\frac{3}{2}$ and $-\frac{1}{3}$

We observe that

$$\text{Sum of the zeroes} = \frac{3}{2} + \left(-\frac{1}{3}\right) = \frac{9-2}{6} = \frac{7}{6}$$

$$= \frac{-(-7)}{6} = \frac{-(\text{coefficient of } x)}{\text{coefficient of } x^2}$$

$$\text{Product of the zeroes} = \left(\frac{3}{2}\right)\left(-\frac{1}{3}\right) = -\frac{1}{2} = -\frac{3}{6} = \frac{\text{constant term}}{\text{coefficient of } x^2}$$

(2) Verify that 1, -1 and -3 are the zeroes of the cubic polynomial x^3+3x^2-x-3 and verify the relationship between zeroes and the coefficients.

Solution: Comparing the given polynomial with ax^3+bx^2+cx+d ,

We get $a=1, b=3, c=-1, d=-3$

$$\text{Let } p(x) = x^3+3x^2-x-3$$

$$P(1) = 1^3+3(1)^2-1-3 = 1+3-1-3 = 0$$

$\therefore P(1) = 0 \Rightarrow 1$ is a zero of the polynomial $p(x)$

$$P(-1) = (-1)^3+3(-1)^2+(-1)-3 = -1+3-1-3 = 0$$

$\therefore p(-1) = 0 \Rightarrow -1$ is a zero of the polynomial $p(x)$

$$p(-3) = (-3)^3+3(-3)^2-(-3) = -27+27+3-3 = 0$$

$\therefore P(-3) = 0 \Rightarrow -3$ is a zero of the polynomial $p(x)$

$\therefore 1, -1, \text{ and } -3$ are the zeroes of x^3+3x^2-x-3 .

So, we take $\alpha=1, \beta=-1, \gamma=-3$

$$\alpha + \beta + \gamma = 1+(-1)+(-3) = -3 = \frac{-3}{1} = \frac{-b}{a} = \frac{-(\text{coefficient of } x^2)}{\text{coefficient of } x^3}$$

$$\alpha\beta+\beta\gamma+\gamma\alpha = (1)(-1)+(-1)(-3)+(3)(1) = -1+3-3 = -1$$

$$= \frac{-1}{1} = \frac{c}{a} = \frac{\text{Coefficient of } x}{\text{Coefficient of } x^3}$$

$$\alpha\beta\gamma = (1)(-1)(-3) = \frac{-(-3)}{1} = \frac{-(\text{constant term})}{\text{coefficient of } x^3}$$

(3) If the zeroes of the polynomial x^2+px+q are double in value to the zeroes of $2x^2-5x-3$, find the values of 'p' and 'q'.

Solution: Given polynomial $2x^2-5x-3$

To find the zeroes of the polynomial, we take

$$2x^2-5x-3 = 0$$

$$2x^2-6x+x-3 = 0$$

$$2x(x-3) + 1(x-3) = 0$$

$$(x-3)(2x+1) = 0$$

$$\Rightarrow x-3 = 0 \quad \text{or} \quad 2x+1 = 0$$

$$\Rightarrow x-3 = 0 \quad \text{or} \quad 2x+1 = 0$$

$$\Rightarrow x = 3 \quad \text{or} \quad x = -\frac{1}{2}$$

\therefore The zeroes of $2x^2-5x-3$ are 3, $-\frac{1}{2}$

\therefore zeroes of the polynomial x^2+px+q are double in the value to the zeroes of $2x^2-5x-3$

i.e. . $2(3)$ and $2\left(-\frac{1}{2}\right)$

$$\Rightarrow 6 \text{ and } -1$$

$$\text{Sum of the zeroes} = 6+(-1) = 5$$

$$\Rightarrow \frac{-p}{1} = 5 \quad (\because \text{sum of the zeroes} = \frac{-(\text{coefficient of } x)}{\text{coefficient of } x^2} = \frac{-p}{1})$$

$$p = -5$$

$$\text{Product of the zeros} = (6)(-1) = -6$$

$$\frac{q}{1} = -6 \quad (\because \text{Product of the zeroes} = \frac{\text{constant term}}{\text{coefficient of } x^2} = \frac{q}{1})$$

$$q = -6$$

∴ The values of p and q are -5, -6

(4). If α and β are the zeroes of the polynomial $6y^2-7y+2$, find a quadratic polynomial whose zeroes are $\frac{1}{\alpha}$ and $\frac{1}{\beta}$

Solution: The given polynomial is

$$6y^2-7y+2$$

Comparing with ay^2+by+c , we get $a=6, b=-7, c=2$

$$\begin{aligned} \therefore \text{Sum of zeroes} &= \alpha + \beta = -\frac{b}{a} = \frac{7}{6} \\ \alpha + \beta &= \frac{7}{6} \dots\dots\dots > (1) \end{aligned}$$

and, a product of zeroes = $\alpha\beta = \frac{c}{a} = \frac{2}{6} = \frac{1}{3}$

$$\alpha\beta = \frac{1}{3} \dots\dots\dots > (2)$$

For a quadratic polynomial whose zeroes are $\frac{1}{\alpha}$ and $\frac{1}{\beta}$

$$\text{Sum of zeroes} = \frac{1}{\alpha} + \frac{1}{\beta} = \frac{\alpha + \beta}{\alpha\beta} = \frac{7/6}{1/3} \quad (\because \text{Form (1) \& (2)})$$

Product of zeroes = $\frac{1}{\alpha} \cdot \frac{1}{\beta} = \frac{1}{\alpha\beta} = \frac{1}{\left(\frac{1}{3}\right)}$ (\because From (2))

\therefore The required quadratic polynomial is

$$K\left\{x^2 - \left(\frac{1}{\alpha} + \frac{1}{\beta}\right)x + \left(\frac{1}{\alpha} \cdot \frac{1}{\beta}\right)\right\}, \text{ where } k \text{ is real.}$$

$$K\left(x^2 - \frac{7}{2}x + 3\right), \text{ } K \text{ is real.}$$

(5) If α and β are the zeroes of a quadratic polynomial such that $\alpha + \beta = 24$ and $\alpha - \beta = 8$, find quadratic polynomial having α and β as its zeroes. Verify the relationship between the zeroes and the coefficient of the polynomial.

Solution: α and β are the zeroes of a quadratic polynomial.

$$\alpha + \beta = 24 \dots\dots\dots > (1)$$

$$\alpha - \beta = 8 \dots\dots\dots > (2)$$

Adding (1) + (2) we get $2\alpha = 32 \Rightarrow \alpha = 16$

Subtraction (1) & (2) we get $2\beta = 16 \Rightarrow \beta = 8$

The quadratic polynomial having α and β as its zeroes is $k\{x^2 - (\alpha + \beta)x + \alpha\beta\}$, where k is real.

$$\Rightarrow K\{x^2 - (16 + 8)x + (16)(8)\}, \text{ } k \text{ is a real}$$

$$\Rightarrow K\{x^2 - 24x + 128\}, \text{ } k \text{ is a real}$$

$$\Rightarrow Kx^2 - 24kx + 128k, \text{ } k \text{ is real}$$

Comparing with $ax^2 + bx + c$, we get $a = k, b = -24k, c = 128k$

$$\text{Sum of the zeroes} = -\frac{b}{a} = \frac{24k}{k} = 24 = \alpha + \beta$$

$$\text{Product of the zeroes} = \frac{c}{a} = \frac{128k}{k} = 128 = \alpha\beta$$

Hence, the relationship between the zeroes and the coefficients is verified.

(6) Find a cubic polynomial with the sum, sum of product of its zeroes taken two at a time, and product of its zeroes as 2, -7, -14 respectively.

Solution: Let α , β and γ are zeroes of the cubic polynomial

$$\text{Given } \alpha + \beta + \gamma = 2$$

$$\alpha\beta + \beta\gamma + \gamma\alpha = -7$$

$$\alpha\beta\gamma = -14$$

Cubic polynomial whose zeroes are α , β and γ is

$$\Rightarrow x^3 - (\alpha + \beta + \gamma)x^2 + (\alpha\beta + \beta\gamma + \gamma\alpha)x - \alpha\beta\gamma$$

$$\Rightarrow x^3 - 2x^2 + (-7)x - (-14)$$

$$\Rightarrow x^3 - 2x^2 - 7x + 14$$

\therefore Required cubic polynomial is $x^3 - 2x^2 - 7x + 14$

(7) Divide x^4-3x^2+4x+5 , by x^2+1-x , and verify the division algorithm.

Solution: Dividend = x^4-3x^2+4x+5
 $= x^4+0x^3-3x^2+4x+5$

Divisor = x^2-x+1

$$\begin{array}{r}
 x^2-x+1 \) \ x^4+0x^3-3x^2+4x+5 \quad (x^2+x-3 \\
 \underline{x^4-x^3+x^2} \\
 (-) \ (+) \ (-) \\
 \ x^3-4x^2+4x \\
 \ \underline{x^3-x^2+x} \\
 (-) \ (+) \ (-) \\
 \ -3x^2+3x+5 \\
 \ \underline{-3x^2+3x-3} \\
 \ (+) \ (-) \ (+) \\
 \ 8
 \end{array}$$

First term quotient

$$\frac{x^4}{x^2} = x^2$$

second term of quotient

$$\frac{x^3}{x^2} = x$$

third term of quotient

$$= \frac{-3x^2}{x^2} = -3$$

We stop here since degree of the remainder is less than the degree of (x^2+x-3) the divisor.

So, quotient = x^2+x-3 , remainder = 8

Verification:

$$\begin{aligned}
 & (\text{Divisor} \times \text{Quotient}) + \text{Remainder} \\
 &= (x^2-x+1)(x^2+x-3)+8 \\
 &= x^4+x^3-3x^2-x^3-x^2+3x+x^2+x-3+8 \\
 &= x^4-3x^2+4x+5 = \text{dividend}
 \end{aligned}$$

∴ Dividend = (Divisor × quotient) + Remainder

∴ The division algorithm is verified.

(9) On division x^3-3x^2+x+2 by a polynomial $g(x)$, the quotient and remainder were $x-2$ and $-2x+4$, respectively. Find $g(x)$.

Solution: Given

$$\text{Dividend} = x^3-3x^2+x+2$$

$$\text{Divisor} = g(x)$$

$$\text{Quotient} = x - 2$$

$$\text{Remainder} = -2x+4$$

By division algorithm

$$\text{Dividend} = ((\text{Divisor} \times \text{quotient}) + \text{Remainder})$$

$$\text{Divisor} = \frac{\text{Dividend} - \text{Remainder}}{\text{Quotient}}$$

$$g(x) = \frac{(x^3 - 3x^2 + x + 2) - (-2x + 4)}{x - 2}$$

$$g(x) = \frac{x^3 - 3x^2 + 3x + 2}{x - 2} \dots\dots\dots(1)$$

$$\begin{array}{r}
 x-2 \) \ x^3 - 3x^2 + 3x - 2 \quad (x^2 - x + 1 \\
 \underline{x^3 - 2x^2} \\
 (-) \ (+) \\
 \underline{-x^2 + 3x} \\
 \underline{+2x} \\
 \underline{(-)} \\
 \underline{x - 2} \\
 \underline{x - 2} \\
 \underline{0}
 \end{array}$$

Short Answer Question

(1) If $P(t) = t^3 - 1$, find the value of $P(1)$, $P(-1)$, $P(0)$, $P(2)$, $P(-2)$

Solution: $P(t) = t^3 - 1$

$$P(1) = 1^3 - 1 = 1 - 1 = 0$$

$$P(-1) = (-1)^3 - 1 = -1 - 1 = -2$$

$$P(0) = 0^3 - 1 = -1$$

$$P(2) = 2^3 - 1 = 8 - 1 = 7$$

$$P(-2) = (-2)^3 - 1 = -8 - 1 = -9$$

(2) Check whether 3 and -2 are the zeros of the polynomial $P(x)$ when $p(x) = x^2 - x - 6$

Solution: Given $p(x) = x^2 - x - 6$

$$P(x) = 3^2 - 3 - 6 = 9 - 3 - 6 = 0$$

$$\begin{aligned} P(x) &= (-2)^2 - (-2) - 6 \\ &= 4 + 2 - 6 \\ &= 0 \end{aligned}$$

Since $p(3) = 0$, $P(-2) = 0$

3 and -2 are zeroes of $p(x) = x^2 - x - 6$

(3) Find the number of zeroes of the given polynomials. And also find their values

(i). $P(x) = 2x + 1$ (ii) $q(x) = y^2 - 1$ (iii) $r(z) = z^3$

Solution:

(i). $P(x) = 2x + 1$ is a linear polynomial. It has only one zero.

To find zeroes.

$$\text{Let } p(x) = 0$$

$$2x + 1 = 0$$

$$\therefore x = -\frac{1}{2}$$

The zero of the given polynomial is $-\frac{1}{2}$

(ii) $q(y) = y^2 - 1$ is a quadratic polynomial. It has at most two zeroes.

To find zeroes, Let $q(y) = 0$

$$y^2 - 1 = 0$$

$$(y+1)(y-1) = 0$$

$$y = -1 \quad \text{or} \quad y = 1$$

\therefore The zeroes of the polynomial are -1 and 1

(iii) $r(z) = z^3$ is a cubic polynomial. It has at most three zeroes.

Let $r(z) = 0$

$$z^3 = 0$$

$$z = 0$$

\therefore The zero of the polynomial is '0'.

(4). Find the quadratic polynomial, with the zeroes $\sqrt{3}$ and $-\sqrt{3}$

Solution: Given

The zeroes of polynomial $\alpha = \sqrt{3}$, $\beta = -\sqrt{3}$

$$\alpha + \beta = -\sqrt{3} + \sqrt{3} = 0$$

$$\alpha\beta = (-\sqrt{3})(\sqrt{3}) = -3$$

The quadratic polynomial with zeroes α and β is given by

$$K\{x^2 - (\alpha + \beta)x + \alpha\beta\}, \quad K(\neq 0) \text{ is real}$$

$$K(x^2 - 0x - 3) \quad k(\neq 0) \text{ is real}$$

$$K(x^2 - 3) \quad K (\neq 0) \text{ is real.}$$

(5) If the Sum and product of the zeroes of the polynomial $ax^2 - 5x + c$ is equal to 10 each, find the values of 'a' and 'c'.

Solution: Given polynomial $ax^2 - 5x + c$

Let the zeroes of the polynomial are α, β

$$\text{Given } \alpha + \beta = 10 \dots\dots\dots (1)$$

$$\text{And } \alpha \beta = 10 \dots\dots\dots (2)$$

We know that

$$\alpha + \beta = -\frac{b}{a} = \frac{-(-5)}{a} = \frac{5}{a} = 10 \quad \because \text{(from (1))}$$

$$a = \frac{5}{10} = \frac{1}{2}$$

$$\alpha \beta = \frac{c}{a} \dots\dots\dots > 10 = \frac{c}{1/2}$$

$$C = 5$$

$$\therefore a = \frac{1}{2}, \quad c = 5$$

(6) If the Sum of the zeroes of the polynomial $P(x) = (a+1)x^2 + (2a+3)x + (3a+4)$, then find the product of its zeroes.

Solution: Given polynomial $P(x) = (a+1)x^2 + (2a+3)x + (3a+4)$

Compare with $ax^2 + bx + c$,

$$\text{we get } a = a + 1$$

$$b = 2a + 3$$

$$c = 3a + 4$$

$$\alpha + \beta = -\frac{b}{a}$$

$$-1 = \frac{-(2a+3)}{a+1}$$

$$\Rightarrow -a - 1 = -2a - 3$$

$$\Rightarrow -a + 2a = -3 + 1$$

$$\Rightarrow a = -2$$

$$\text{Product of the zeroes} = \alpha \beta = \frac{c}{a} = \frac{3a + 4}{a + 1}$$

$$= \frac{3(-2) + 4}{-2 + 1} = \frac{-2}{-1} = 2$$

(7) On dividing the polynomial $2x^3 + 4x^2 + 5x + 7$ by a polynomial $g(x)$, the quotient and the remainder were $2x$ and $7 - 5x$ respectively. Find $g(x)$

Solution: Given

$$\text{Dividend} = 2x^3 + 4x^2 + 5x + 7$$

$$\text{Divisor} = g(x)$$

$$\text{Quotient} = 2x$$

$$\text{Remainder} = 7 - 5x$$

By division algorithm

$$\text{Dividend} = (\text{divisor} \times \text{quotient}) + \text{remainder}$$

$$\text{Divisor} = \frac{\text{dividend} - \text{remainder}}{\text{quotient}}$$

$$g(x) = \frac{(2x^3 + 4x^2 + 5x + 7) - (7 - 5x)}{2x}$$

$$= \frac{2x^3 + 4x^2 + 5x + 7 - 7 + 5x}{2x}$$

$$= \frac{2x^3 + 4x^2 + 10x}{2x}$$

$$= \frac{2x(x^2 + 2x + 5)}{2x}$$

$$g(x) = x^2 + 2x + 5$$

(8) If $p(x) = x^3 - 2x^2 + kx + 5$ is divided by $(x - 2)$, the remainder is 11. Find K.

Solution:

$$\begin{array}{r} x-2 \) \ x^3 - 2x^2 + kx + 5 \quad (x^2 + k \\ \underline{x^3 - 2x^2} \\ kx + 5 \\ \underline{kx - 2k} \\ (-) (+) \\ 2k + 5 \end{array}$$

Remainder = $2k + 5 = 11$ (given)

$$k = \frac{11 - 5}{2} = 3$$

Very Short Answer Questions

(1) Write a quadratic and cubic polynomials in variable x in the general form.

Solution:

The general form of the a quadratic polynomial is ax^2+bx+c , $a \neq 0$

The general form of a cubic polynomial is ax^3+bx^2+cx+d , $a \neq 0$

(2) If $p(x) = 5x^7 - 6x^5 + 7x - 6$,find (Problem solving)

- (i) Co – efficient of x^5 (ii) degree of $p(x)$

Solution:

Given polynomial $p(x) = 5x^7 - 6x^5 + 7x - 6$

(i) Co – efficient of x^5 is ‘-6’

(ii) Degree of $p(x)$ is ‘7’

(3) Check whether – 2 and 2 are the zeroes of the polynomial $x^4 - 16$

(Reasoning proof)

Solution: $p(x) = x^4 - 16$

$$P(2) = 2^4 - 16 = 16 - 16 = 0$$

$$P(-2) = (-2)^4 - 16 = 16 - 16 = 0$$

Since $P(2) = 0$ and $P(-2) = 0$

\therefore -2 , 2 are the zeroes of given polynomial

(4) Find the quadratic polynomial whose sum and product of its zeroes

respectively $\sqrt{2}, \frac{1}{3}$ (Communication)

Solution: Given

$$\text{Sum of the zeroes } \alpha + \beta = \sqrt{2} \dots\dots\dots > (1)$$

$$\text{Product of the zeroes } \alpha \beta = \frac{1}{3} \dots\dots\dots > (2)$$

The quadratic polynomial with α and β as zeroes is $K\{x^2 - (\alpha + \beta)x + \alpha\beta\}$, where $k(\neq 0)$ is a real number.

$$K\{x^2 - \sqrt{2}x + \frac{1}{3}\}, K(\neq 0) \text{ is a real number} \quad (\because \text{From (1) \& (2)})$$

$$k\left(\frac{3x^2 - 3\sqrt{2}x + 1}{3}\right), k(\neq 0) \text{ is real number}$$

We can put different values of 'k'

$$\therefore \text{ when } k = 3, \text{ we get } 3x^2 - 3\sqrt{2}x + 1$$

(5) If the sum of the zeroes of the quadratic polynomial $f(x) = kx^2 - 3x + 5$ is 1. Write the value of K.

Solution: Given polynomial $f(x) = kx^2 - 3x + 5$

$$\text{Sum of the zeroes } \alpha + \beta = \frac{-b}{a}$$

$$1 = \frac{-(-3)}{k} \quad (\because \text{Given } \alpha + \beta = 1)$$

$$K = 3$$

(6) From the graph find the zeroes of the polynomial.

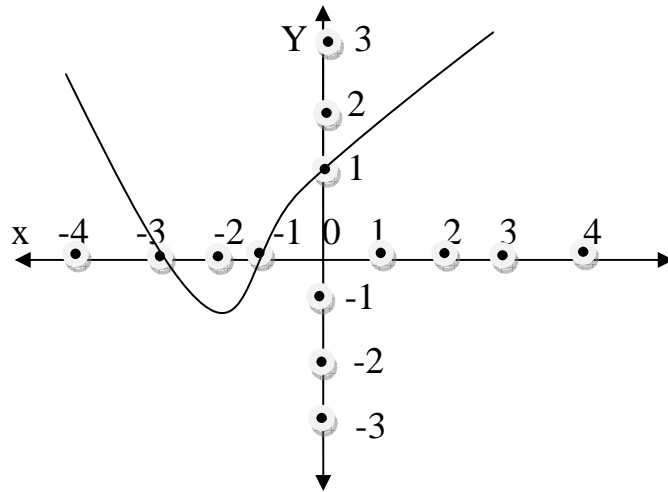

Solution: The zeroes of the polynomial are precisely the x – co-ordinates of the point .

Where the curve intersects the x- axis

∴ From the graph the zeroes are – 3 and -1.

(7) If $a - b$, $a + b$ are zeroes of the polynomial $f(x) = 2x^3 - 6x^2 + 5x - 7$, write the value of the a .

Solution: Let α, β, γ are the zeroes of cubic polynomial

$$ax^3 + bx^2 + cx + d \text{ then } \alpha + \beta + \gamma = \frac{-b}{a}$$

$$a - b + a + a + b = \frac{-(-6)}{2}$$

$$3a = 3$$

$$a = 1$$

Objective Type Questions

(1) The graph of the polynomial $f(x) = 3x - 7$ is a straight line which intersects the x-axis at exactly one point namely []

- (A) $(\frac{-7}{3}, 0)$ (B) $(0, \frac{-7}{3})$ (C) $(\frac{7}{3}, 0)$ (D) $(\frac{7}{3}, \frac{-7}{3})$

(2) In the given figure, the number of zeros of the polynomial $f(x)$ are []

- (A) 1 (B) 2 (C) 3 (D) 4

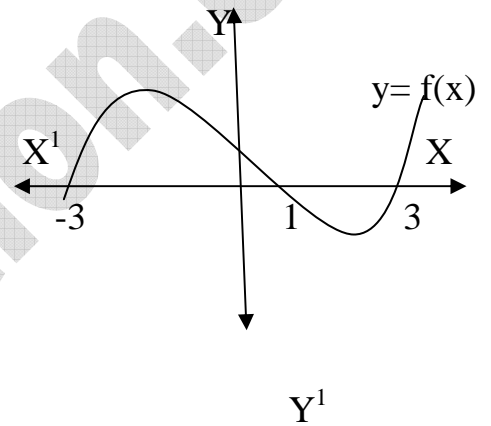

(3) The number of zeros lying between -2 and 2 of the polynomial $f(x)$ whose graph is given figure is []

- (A) 2 (B) 3 (C) 4 (D) 1

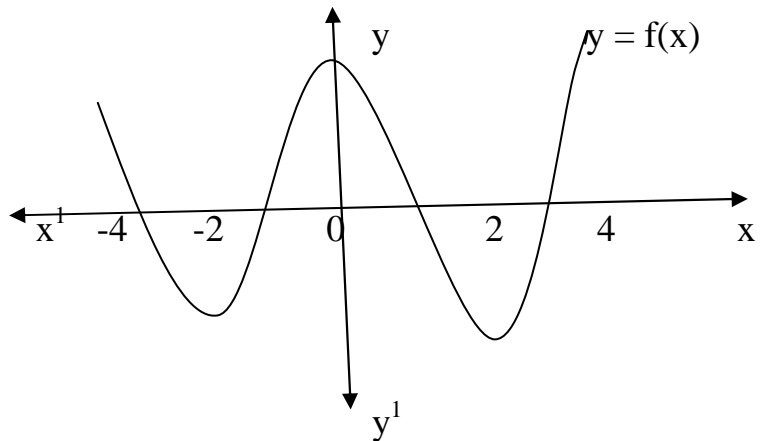

(4) Which of the following is not a quadratic polynomial []

(A) X^2+3x+4

(B) x^2-3x+4

(C) $6+(x^2-4x)$

(D) $(x-3)(x+3)-(x^2+7x)$

(5) The degree of the constant polynomial is []

(A) 0

(B) 1

(C) 2

(D) 3

(6) The zero of $p(x) = ax - b$ is []

(A) a

(B) b

(C) $\frac{-b}{a}$,

(D) $\frac{b}{a}$

(7) Which of the following is not a zero of the polynomial $x^3-6x^2+11x-6$?.....[]

(A) 1

(B) 2

(C) 3

(D) 0

(8) If α and β are the zeroes of the polynomial $3x^2+5x+2$, then the value of $\alpha+\beta+\alpha\beta$ is []

(A) - 1

(B) - 2

(C) 1

(D) 4

(9) If the sum of the zeroes of the polynomial $p(x) = (k^2-14)x^2 -2x-12$ is 1, then k. takes the value(s) []

(A) $\sqrt{14}$

(B) -14

(C) 2

(D) ± 4

(10) If α, β are zeroes of $p(x) = x^2-5x+k$ and $\alpha - \beta = 1$ then the value of k is []

(A) 4

(B) - 6

(C) 2

(D) 5

(11) If α, β, γ are the zeros of the polynomial ax^3+bx^2+cx+d , then the value of $\frac{1}{\alpha} + \frac{1}{\beta} + \frac{1}{\gamma}$ is []

- (A) $\frac{c}{d}$ (B) $\frac{-c}{d}$ (C) $\frac{b}{d}$ (D) $\frac{-b}{d}$

(12) If the product of the two zeros of the polynomial $x^3-6x^2+11x-6$ is 2 is then the third zero is []

- (A) 1 (B) 2 (C) 3 (D) 4

(13) The zeros of the polynomial is x^3-x^2 are []

- (A) 0, 0, 1 (B) 0, 1, 1 (C) 1, 1, 1 (D) 0, 0, 0

(14) If the zeroes of the polynomial x^3-3x^2+x+1 are $\frac{a}{r}$, a and r then the value of a is []

- (A) 1 (B) -1 (C) 2 (D) -3

(15) If α and β are the zeroes of the quadratic polynomial $9x^2-1$, find the value of $\alpha^2+\beta^2$ []

- (A) $\frac{1}{9}$ (B) $\frac{2}{9}$ (C) $\frac{1}{3}$ (D) $\frac{2}{3}$

(16) If α, β, γ are the zeroes of the polynomial x^3+px^2+qx+r then find []

$$\frac{1}{\alpha\beta} + \frac{1}{\beta\gamma} + \frac{1}{\gamma\alpha}$$

- (A) $\frac{p}{r}$ (b) $-\frac{p}{r}$ (C) $\frac{q}{r}$ (D) $\frac{-q}{r}$

(17) The number to be added to the polynomial x^2-5x+4 , so that 3 is the zero of the polynomial is []

- (a) 2 (B) -2 (C) 0 (D) 3

(18). If $\alpha,$ and β are zeroes of $p(x) = 2x^2-x-6$ then the value of $\alpha^{-1} + \beta^{-1}$ is []

- (A) $\frac{1}{6}$ (B) $\frac{-1}{6}$ (C) $\frac{1}{2}$ (D) $\frac{-1}{3}$

(19). What is the coefficient of the first term of the quotient when $3x^3+x^2+2x+5$ is Divided by $1+2x+x^2$ []

- (A) 1 (B) 2 (C) 3 (D) 5

(20) If the divisor is x^2 and quotient is x while the remainder 1, then the dividend is []

- (A) x^2 (B) x (C) x^3 (D) x^3+1

Key:

1. C 2. C 3. A 4. D 5. A 6. D 7. D 8. A 9. D 10. C

11. B 12. C 13. A 14. B 15. B 16. A 17. A 18. B 19. C 20. D

Fill in the Blanks

- (1) The maximum number of zeroes that a polynomial of degree 3 can have is 3
- (2) The number of zeroes that the polynomial $f(x) = (x-2)^2 + 4$ can have is 2
- (3) The graph of the equation $y = ax^2 + bx + c$ is an upward parabola, If $(a > 0)$
- (4) If the graph of a polynomial does not intersect the x – axis, then the number zeroes of the polynomial is 0
- (5) The degree of a biquadratic polynomial is 4
- (6) The degree of the polynomial $7\mu^6 - \frac{3}{2}\mu^4 + 4\mu + \mu - 8$ is 6
- (7) The values of $p(x) = x^3 - 3x - 4$ at $x = -1$ is -2
- (8) The polynomial whose whose zeroes are -5 and 4 is $x^2 + x - 20$
- (9) If -1 is a zeroes of the polynomial $f(x) = x^2 - 7x - 8$ then other zero is 8
- (10) If the product of the zeroes of the polynomial $ax^3 - 6x^2 + 11x - 6$ is 6, then the value of a is 1
- (11) A cubic polynomial with the sum, sum of the product of its zeroes taken two at a time, and the product of its zeroes are 2, -7 and -14 respectively, is $x^3 - 2x^2 - 7x + 14$
- (12) For the polynomial $2x^3 - 5x^2 - 14x + 8$, find the sum of the products of zeroes, taken two at a time is -7

(13) If the zeroes of the quadratic polynomial ax^2+bx+c are reciprocal to each other,

Then the value of c is a

(14) What can be the degree of the remainder at most when a biquadrate polynomial is divided by a quadratic polynomial is 1

sakshieducation.com

Chapter-1

REAL NUMBERS

Fundamental Theorem of Arithmetic:

Every composite number can be expressed (factorised) as a product of primes, and this factorization is unique, apart from the order in which the prime factors occur.

Ex: $30 = 2 \times 3 \times 5$

LCM and HCF: If a and b are two positive integers. Then the product of a, b is equal to the product of their LCM and HCF.

$$\text{LCM} \times \text{HCF} = a \times b$$

To Find LCM and HCF of 12 and 18 by the prime factorization method.

$$12 = 2 \times 2 \times 3 = 2^2 \times 3^1$$

$$18 = 2 \times 3 \times 3 = 2 \times 3^2$$

$$\text{HCF of 12 and 18} = 2^1 \times 3^1 = 6$$

(Product of the smallest powers of each common prime factors in the numbers)

$$\text{LCM of 12 and 18} = 2^2 \times 3^2 = 36$$

(Product of the greatest powers of each prime factors in the numbers)

$$\text{Product of the numbers} = 12 \times 18 = 216$$

$$\text{LCM} \times \text{HCF} = 36 \times 6 = 216$$

\therefore Product of the numbers = LCM \times HCF

- Natural numbers Set $N = \{1, 2, 3, 4, \dots\}$
- Whole number Set $W = \{0, 1, 2, 3, 4, \dots\}$
- Integers z(or) $I = \{\dots, -3, -2, -1, 0, 1, 2, 3, \dots\}$

Rational numbers (Q): If p, q are whole numbers and $q \neq 0$ then the numbers in the form

$\frac{p}{q}$ of q are called **Rational numbers**.

Rational numbers Set $Q = \left\{ \frac{p}{q} / p, q \in \mathbb{Z}, q \neq 0, \text{HCF}(p, q) = 1 \right\}$

All rational numbers can be written either in the form of terminating decimals or non-terminating repeating decimals.

Ex: $-\frac{2}{7}, \frac{5}{2}, -4, 3, 0, \dots$

Between two distinct rational numbers there exist infinite number of rational numbers.

A rational number between 'a' and 'b' = $\frac{a + b}{2}$

Terminating Decimals in Rational Numbers:

Let x be a rational number whose decimal expansion terminates. Then x can be expressed in the form, $\frac{p}{q}$ where p and q are co-prime, and the prime factorization of q is of the form $2^n \cdot 5^m$, where n, m are non-negative integers.

Conversely

Let x = $\frac{p}{q}$ be a rational number, such that the prime factorization of q is of the form $2^n \cdot 5^m$, where n, m are non-negative integers. Then x has a decimal expansion which terminate.

Ex: In the rational number $\frac{3}{20}$, p = 3, q = 20 q = 20 = 2 × 2 × 5 = $2^2 \times 5^1$ in the form of $2^n 5^m$.

∴ $\frac{3}{20}$ Is in the form of terminating decimal.

$$\text{and } \frac{3}{20} = \frac{3}{2^2 \times 5^1} = \frac{3 \times 5}{2^2 \times 5^2} = \frac{15}{(10)^2} = \frac{15}{100} = 0.15$$

Non-terminating, Recurring Dceimals In Rational Numbers:

Let $x = \frac{p}{q}$ be a rational number, Such that the prime factorization of q is not of the form $2^n 5^m$, where n, m are non-negative integers. Then x has a decimal expansion. which is non-terminating repeating(recurring).

Ex : In the rational number , $p=11, q=30$

$q=30= 2 \times 3 \times 5$ is not in the form of $2^n 5^m$

$\therefore \frac{11}{30}$ is non-terminating, repeating decimal.

Irrational Numbers (\mathbb{Q}^1):

The numbers cannot written in the form of $\frac{p}{q}$ are called irrational numbers.

The decimal expansion of every irrational numbers is non-terminating and repeating.

Ex: $\pi, \sqrt{2}, \sqrt{3}, \sqrt{12}, 0.1011011001100 \dots$

- An irrational number between a and $b = \sqrt{ab}$
- \sqrt{p} is irrational, where P is Prime.

Ex: $\sqrt{2}, \sqrt{3}, \sqrt{5}, \sqrt{7}, \sqrt{11} \dots$

Let P be a prime number . Let p divides a^2 . Then P divides a , where a is a positive integer.

- Sum (or difference) of a rational number and an irrational number is an irrational numbers.
- Product (or quotient) of non-zero rational and an irrational number is an irrational numbers.
- The Sum of the two irrational numbers need not be irrational.
 $\sqrt{2}, -\sqrt{2}$ are irrational but $\sqrt{2} + (-\sqrt{2}) = 0$, Which is rational.
- Product of two irrational number need not be irrational.

Ex: $\sqrt{2}, \sqrt{8}$ are irrational but $\sqrt{2} \cdot \sqrt{8} = \sqrt{16} = 4$ which is rational.

Real Numbers (R):

The Set of rational and irrational numbers together are called real numbers.

$$R = Q \cup Q^1$$

- Between two distinct real numbers there exists infinite number of real number.
- Between two distinct real numbers there exists infinite number of rational and irrational number.
- With respect to addition Real numbers are Satisfies closure, Commutative, Associative, Identity, Inverse and Distributive properties.

Here '0' is the additive identity and additive inverse of a is - a

- With respect to multiplication, non-zero real numbers are Satisfies closure, Commutative, Associative, Identity, Inverse properties.
Here '1' is the multiplicative identity.

For a ($\neq 0$) $\in R$, $\frac{1}{a}$ is the multiplication inverse of 'a'.

$$N \subset W \subset Z \subset Q \subset R$$

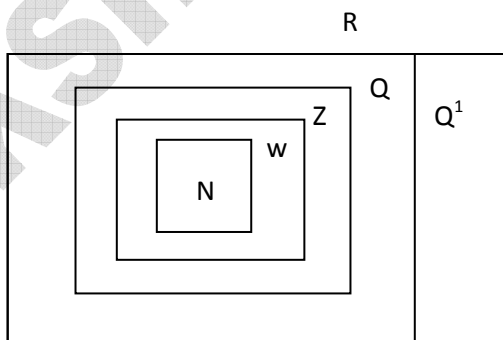

Logarithms:

Logarithms are used for all sort of calculations in engineering, Science, business and economics.

If $a^n = x$; we write it as $\log_a x = n$, where a and x are positive numbers and $a \neq 1$.

Logarithmic form of $a^n = x$ is $\log_a x = n$

Exponential form of $\log_a x = n$ is $a^n = x$

Ex: Logarithmic form of $4^3 = 64$ is $\log_4 64 = 3$

Ex: Exponential form of $\log_4 64 = 3$ is $4^3 = 64$.

The logarithms of the same number to different bases are different

Ex: $\log_4 64 = 3$, $\log_8 64 = 2$

The logarithm of 1 to any base is zero i.e. $\log_a 1 = 0$, $\log_2 1 = 0$

The logarithm of any number to the same base is always one.

i.e. $\log_a a = 1$, $\log_{10} 10 = 1$

Laws of logarithms:

$$(1). \log_a x y = \log_a x + \log_a y$$

$$(2). \log_a \frac{x}{y} = \log_a x - \log_a y$$

$$(3). \log_a x^m = m \cdot \log_a x$$

The logarithm of a number consists of two parts.

(i). The integral part of the logarithm (Characteristic).

(ii). The fractional or decimal part of the logarithm (Mantissa)

Ex: $\log_{10} 16 = 1.2040$

Characteristic = 1

Mantissa = 0.2040

Essay Type Questions:

(1). Prove that $\sqrt{3}$ is irrational .

Solution: Since we are using proof by contradiction

Let us assume the contrary

i.e $\sqrt{3}$ is rational.

If it is rational, then there exist two integers

a and b, $b \neq 0$, Such that $\sqrt{3} = \frac{a}{b}$ >(1)

and also a,b are co-Prime (i.e. $HCF(a, b) = 1$)

$$\sqrt{3} = \frac{a}{b}$$

Squaring on both sides, we get

$$3b^2 = a^2 \text{>(2)}$$

$$\therefore 3 \text{ divide } a^2$$

3 divides a (\because p is a Prime number. If p divided a^2 , then p divides a. where a is positive integers)

So, we can write

$$a = 3k \text{ for some integer } k.$$

Substituting in equation (2) , we get

$$3b^2 = (3k)^2$$

$$3b^2 = 9k^2$$

$$b^2 = 3k^2$$

$$3 \text{ divides } b^2$$

∴ P is a prime number. If p divided a^2 , then p divides a.)

∴ a and b have at least 3 as a common factor.

But this contradicts the fact that a and b have no common factor other than 1.

This means that our Supposition is wrong.

Hence, $\sqrt{3}$ is an irrational.

(2). Prove that $3+2\sqrt{5}$ is irrational (Reasoning Proof)

Solution: Let us assume, to the contrary, that $3+2\sqrt{5}$ is rational.

i.e, we can find co-primes a and b,

$$b \neq 0 \text{ such that } 3+2\sqrt{5} = \frac{a}{b}$$

$$\frac{a}{b} - 3 = 2\sqrt{5}$$

$$\frac{a - 3b}{b} = 2\sqrt{5}$$

$$\frac{a - 3b}{2b} = \sqrt{5}$$

Since a and b are integers, we get $\frac{a - 3b}{2b}$ is rational

$$\left(\because \frac{a - 3b}{2b} = \sqrt{5} \right)$$

So $\sqrt{5}$ is rational

But this contradicts the fact that $\sqrt{5}$ is irrational.

This contradiction has fact arisen because of our incorrect assumption that $3 + 2\sqrt{5}$ rational.

So we conclude that $3 + 2\sqrt{5}$ is irrational .

(3). Prove that $\sqrt{5} + \sqrt{2}$ is irrational (Reasoning Proof)

Solution: Since we are using proof by contradiction

Let us assume the contrary

i.e $\sqrt{5} + \sqrt{2}$ rational

Let $\sqrt{5} + \sqrt{2} = \frac{a}{b}$, where a, b are integers and $b \neq 0$.

$$\sqrt{2} = \frac{a}{b} - \sqrt{5}$$

Squaring on the both sides

$$(\sqrt{2})^2 = \left(\frac{a}{b} - \sqrt{5}\right)^2$$

$$2 = \frac{a^2}{b^2} - 2\sqrt{5} \frac{a}{b} + 5$$

$$2\sqrt{5} \frac{a}{b} = \frac{a^2}{b^2} + 5 - 2$$

$$2\sqrt{5} \frac{a}{b} = \frac{a^2}{b^2} + 3$$

$$2\sqrt{5} \frac{a}{b} = \frac{a^2 + 3b^2}{b^2} \qquad \sqrt{5} = \frac{a^2 + 3b^2}{b^2} \cdot \frac{b}{2a}$$

$$\sqrt{5} = \frac{a^2 + 3b^2}{2ab}$$

Since a, b are integers $\frac{a^2 + 3b^2}{2ab}$ is rational and so, $\sqrt{5}$ is rational .

This contradict the fact that $\sqrt{5}$ is irrational .

Hence $\sqrt{5} + \sqrt{2}$ is irrational.

(4). Prove the first law of logarithms (Reasoning proof)

Solution:

The first law of logarithms states

$$\log_a x y = \log_a x + \log_a y$$

Let $x = a^n$ and $y = a^m$ where $a > 0$ and $a \neq 1$.

Then we know that we can write

$$\log_a x = n \text{ and } \log_a y = m \dots\dots\dots >(1)$$

Using the first law of exponents we know that

$$a^n \cdot a^m = a^{n+m}$$

$$x \cdot y = a^n \cdot a^m = a^{n+m}$$

$$\text{i.e } x y = a^{n+m}$$

writing in the logarithmic form, we Know that

$$\log_a x y = n+m \dots\dots\dots >(2)$$

$$\log_a x y = \log_a x + \log_a y \quad (\text{from (1)})$$

Model Question: Prove the Second law of logarithms

$$\log_a \frac{x}{y} = \log_a x - \log_a y$$

(5). Prove the third law of logarithms states (Reasoning proof)

Solution:

The third law of logarithms states

$$\log_a x^m = m \log_a x$$

Let $x = a^n$ so $\log_a x = n$ >(1)

Suppose ,we raise both sides of $x = a^n$ to the power m , we get

$$x^m = (a^n)^m$$

$$x^m = a^{nm} \quad (\text{Using the laws of exponents})$$

$$x^m = a^{nm}$$

Writing in the logarithmic form ,we get

$$\text{Log}_a x^m = nm$$

$$=m n$$

$$m. \log_a x \quad (\text{from equation (1)})$$

$$\therefore \log_a x^m = m \log_a x$$

Short Answer Question:

Q(1). Find the LCM and HCF of the number 336 and 54 and verify that $LCM \times HCF = \text{product of the two numbers}$.

Solution:

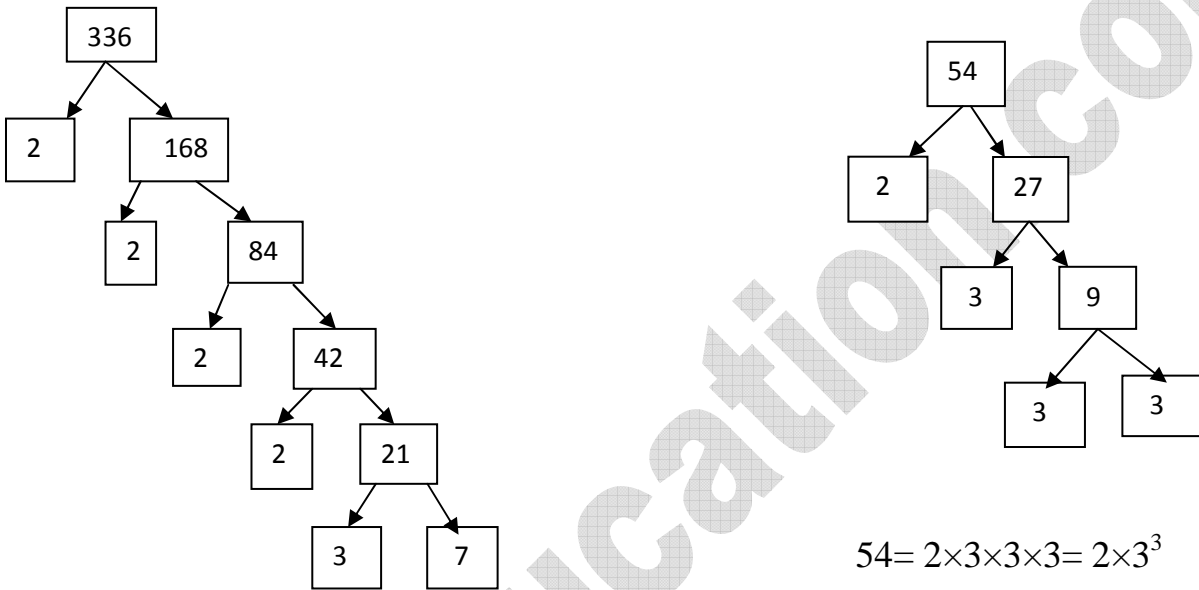

$$336 = 2 \times 2 \times 2 \times 2 \times 3 \times 7 = 2^4 \times 3 \times 7$$

$$54 = 2 \times 3 \times 3 \times 3 = 2 \times 3^3$$

There fore

$$\begin{aligned} LCM(336, 54) &= \text{Product of the greatest power of each prime factors, in the number} \\ &= 2^4 \times 3^3 \times 7 = 3024 \end{aligned}$$

HCF(336, 54) = Product of the smallest power of each common prime factors, in the numbers

$$= 2 \times 3 = 6$$

Verification:

$LCM \times HCF = \text{Product of two numbers}$

$$3024 \times 6 = 336 \times 54$$

$$18144 = 18144$$

Hence Verified.

Q(2). Find the value of X, Y and Z in the following factor tree. Can the value of 'x' be found without finding the value of 'Y' and 'Z' If yes , Explain.

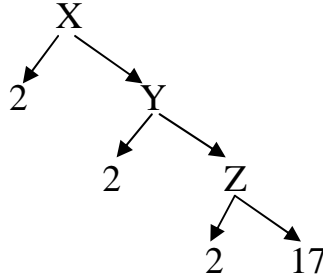

Solution: From the factor tree

$$z = 2 \times 17 = 34$$

$$y = 2 \times z = 2 \times 34 = 68$$

$$x = 2 \times y = 2 \times 68 = 136$$

Yes, the value of the x can be found without finding the value of 'y' and 'z' as follow :

$$x = 2 \times 2 \times 2 \times 17 = 136$$

Q(3). Sita takes 35 seconds to pack and label a box. For Ram, the same job takes 42 seconds and for Geeta, it takes 28 seconds. If they all start using labeling machines at the same time, after how many seconds will they be using the labeling machines together? (communication)

Solution:

Required number of seconds is the LCM of 35, 42 and 28

$$35 = 5 \times 7$$

$$42 = 2 \times 3 \times 7$$

$$28 = 2 \times 2 \times 7$$

$$\text{LCM of } 35, 42 \text{ and } 28 = 2^2 \times 3 \times 5 \times 7$$

$$=420$$

Hence Sita, Ram and Geeta will be using the labeling machines together after 420 seconds, i.e 7 minutes.

Q(4). Explain why $(17 \times 11 \times 2) + (17 \times 11 \times 5)$ is a composite number?

(Reasoning proof)

Solution: $(17 \times 11 \times 2) + (17 \times 11 \times 5)$

$$17 \times 11 \times (2+5) = 17 \times 11 \times 7$$

Since $(17 \times 11 \times 2) + (17 \times 11 \times 5)$ can be expressed as product of prime, it is a composite number.

Q(5). Without actual division, State whether the following rational number are terminating or non-terminating, repeating decimal.

(i). $\frac{15}{200}$

(ii). $\frac{64}{455}$

Solution:

(I). $\frac{15}{200} = \frac{3 \times 5}{40 \times 5} = \frac{3}{40} = \frac{3}{2^3 \times 5}$

Here $q = 2^3 \times 5^1$, which is of the form $2^n \cdot 5^m$

($n=3, m=1$). So, the rational number $\frac{15}{200}$ has a terminating decimal expansion.

(II). $\frac{64}{455} = \frac{64}{5 \times 7 \times 13}$

$$\frac{64}{455}$$

Here $q = 5 \times 7 \times 13$, which is not the form $2^n \cdot 5^m$. So, the rational number

Has a non-terminating repeating decimal expansion.

(6). Write the decimal expansion of the following rational number without actual division. (communication)

(i) $\frac{143}{110}$ (ii) $\frac{16}{3125}$

(i). $\frac{143}{110} = \frac{11 \times 13}{11 \times 10} = \frac{13}{10} = 0.3$

(ii). $\frac{16}{3125} = \frac{16}{5^5} = \frac{16 \times 2^5}{5^5 \times 2^5} = \frac{16 \times 32}{(5 \times 2)^5} = \frac{512}{10^5}$

$= \frac{512}{100000} = 0.00512$

(7). Prove that $\frac{2\sqrt{3}}{5}$ is an irrational (Reasoning proof)

Solution: Let us assume, to the contrary, that $\frac{2\sqrt{3}}{5}$ is rational. Then there exist

Co-prime positive integers 'a' and 'b' such that

$$\frac{2\sqrt{3}}{5} = \frac{a}{b}$$

$$\sqrt{3} = \frac{5a}{2b}$$

is rational

\therefore 5, a, 2, b, are integers, $\therefore \frac{5a}{2b}$ is a rational numbers)
This contradicts the fact that $\sqrt{3}$ is irrational.

So, our assumption is not correct

Hence $\frac{2\sqrt{3}}{5}$ is an irrational number.

(8). Determine the value of the following(Problem solving)

(i) $\text{Log}_2 \frac{1}{16}$

(2) $\text{Log}_x \sqrt{3}$

(i) Let $\log_2 \frac{1}{16} = t$, then the exponential form is $2^t = \frac{1}{16}$

$$2^t = \frac{1}{2^4}$$

$$2^t = 2^{-4}$$

$$t = -4$$

$$\log_2 \frac{1}{16} = -4$$

(ii) Let $\log_x \sqrt{x} = t$, then the exponential form is

$$x^t = \sqrt{x}$$

$$x^t = x^{\frac{1}{2}}$$

$$t = \frac{1}{2}$$

$$\log_x \sqrt{x} = \frac{1}{2}$$

(9) Write each of the following expression as $\log N$.

(i) $2 \log 3 - 3 \log 2$

(ii) $\log 10 + 2 \log 3 - \log 2$ (problem solving)

$$2 \log 3 - 3 \log 2 = \log 3^2 - \log 2^3 \quad (\because m \log x = \log x^m)$$

$$= \log 9 - \log 8$$

$$= \log \frac{9}{8} \quad (\because \log x - \log y = \log \frac{x}{y})$$

$$(ii) \log 10 + 2 \log 3 - \log 2 = \log 10 + \log 3^2 - \log 2 \quad (\because m \log x = \log x^m) =$$

$$= \log 10 + \log 9 - \log 2$$

$$\log(10 \times 9) - \log 2 \quad (\because \log x + \log y = \log xy)$$

$$= \log 90 - \log 2$$

$$= \log \frac{90}{2} \quad (\because \log x - \log y = \log \frac{x}{y})$$

www.sakshieducation.com

$$= \log 45$$

(10). Expand the following

(i) $\log \frac{128}{625}$

(ii) $\log \sqrt{\frac{x^3}{y^2}}$

(i) $\log \frac{128}{625} = \log 128 - \log 625$

$= \log 2^7 - \log 5^4$

$= 7 \log 2 - 4 \log 5$

$(\because \log x^m = m \log x)$

(ii) $\log \sqrt{\frac{x^3}{y^2}} = \log \left(\frac{x^3}{y^2}\right)^{\frac{1}{2}}$

$= \log \frac{x^{\frac{3}{2}}}{y}$

$= \log x^{\frac{3}{2}} - \log y$

$\frac{3}{2} \log x - \log y$

Very Short Answer Question:

(i) Find any rational number between the numbers

$$3\frac{1}{3} \text{ and } 3\frac{2}{3} \quad (\text{problemsolving})$$

Solve:

$$\text{Given numbers } 3\frac{1}{3} \text{ and } 3\frac{2}{3}$$

$$= \frac{10}{3} \text{ and } \frac{11}{3}$$

The rational numbers between 'a' and 'b' is $\frac{a+b}{2}$

$$\text{The rational numbers between } 3\frac{1}{3} \text{ and } 3\frac{2}{3} \text{ is } \frac{3\frac{1}{3} + 3\frac{2}{3}}{2}$$

$$= \frac{7}{2}$$

$$= 3.5$$

(2) Represent the number $\frac{9}{10}$ on the number line. (Visualization and Representation)

Solution:

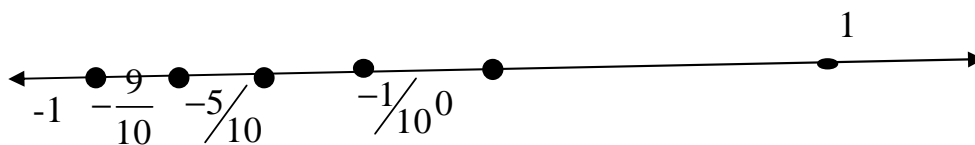

(3) Express the numbers 5005 as a product of its prime factors. (communication)

Solve:

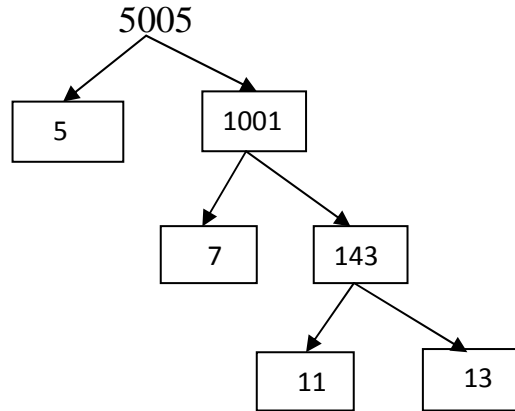

So, $5005 = 5 \times 7 \times 11 \times 13$

(4). Given that $HCF(306, 657) = 9$. Find $LCM(306, 657)$ (problem solving)

Solve:

$$LCM \times HCF = \text{Product of numbers}$$

$$LCM(306, 657) = \frac{306 \times 657}{HCF(306, 657)} = \frac{306 \times 657}{9} = 22338$$

(5). Check whether 6^n can end with the digit 0 for any natural number 'n'.

(Reasoning poof)

Solution: we know that any positive integers ending with the digit zero is divisible by 5 and so its prime factorization must contain the prime 5.

We have

$$6^n = (2 \times 3)^n = 2^n \times 3^n$$

The only primes in the factorization of 6^n are 2 and 3

There are no other primes in the factorization of 6^n

(By uniqueness of the fundamental Theorem of Arithmetic)

5 does not occur in the prime factorization of 6^n for any n.

6^n does not end with the digit zero for any natural number n.

(6). Write (i) $3^5 = 243$ (ii) $10^{-3} = 0.001$ in the logarithmic form. (Communication)

(i). The logarithmic form of $3^5 = 243$ is $\log_3 243 = 5$

(ii) The logarithmic form of $10^{-3} = 0.001$ is $\log_{10} 0.001 = -3$

(7). Write (i) $\log_4 64 = 3$

(ii) $\log_a \sqrt{x} = b$ in exponential form (Communication)

Solve:

(i). The exponential form of $\log_4 64 = 3$ is $4^3 = 64$

(ii). The exponential form of $\log_a \sqrt{x} = b$ is $a^b = \sqrt{x}$

(8). Expand $\log 15$ (Problem solving)

Solution: $\log 15 = \log (3 \times 5) = \log 3 + \log 5$ ($\because \log x y = \log x + \log y$)

(9). Explain why $3 \times 5 \times 7 + 7$ is a composite number. (Reasoning proof)

Solution: $3 \times 5 \times 7 + 7 = 7(3 \times 5 \times 1 + 1) = 7 \times (16) = 2 \times 2 \times 2 \times 2 \times 7$
 $= 2^4 \times 7$

Since $3 \times 5 \times 7 + 7$ can be expressed as a product of primes therefore by fundamental theorem of Arithmetic it is a composite no.

Multiple Choice Questions

- (1). The prime factor of $2 \times 7 \times 11 \times 17 \times 23 + 23$ is []
(A) 7 (B) 11 (C) 17 (D) 23
- (2). A physical education teacher wishes to distribute 60 balls and 135 bats equally among a number of boys. Find the greatest number receiving the gift in this way..... []
(A) 6 (B) 12 (C) 18 (D) 15
- (3). The Values of x and y in the given figure are []

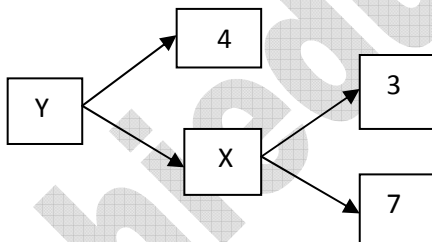

- (A) $X = 10, Y = 14$ (B) $X = 21, Y = 84$
(C) $X = 21, Y = 25$ (D) $X = 10, Y = 40$
- (4). If the LCM of 12 and 42 is $10m + 4$, then the value of 'm' is []
(A) 50 (B) 8 (C) $\frac{1}{5}$ (D) 1
- (5). π is []
(A) An irrational number (B) a rational number

(C) a prime number

(D) a composite number

(6) which of the following is not an irrational number? []

- (A) $\sqrt{2}$ (B) $\sqrt{3}$ (C) $\sqrt{4}$ (4) $\sqrt{5}$

(7) The reciprocal of two irrational numbers is []

- (A) Always rational number
(B) Always an irrational number
(C) Sometime a rational number, Sometime an irrational
(D) Not a real number

(8) The decimal $\frac{17}{8}$ expansion of is []

- (A) 2.125 (B) 2.25 (C) 2.375 (D) 2.0125

(9) $2.54\bar{7}$ is []

- (A) An integer (B) An irrational (C) A rational (D) A prime number

(10) Decimal expansion of number $\frac{27}{2 \times 5 \times 4}$ has []

- (A) A terminating decimal (B) non –terminating but repeating
(C) Non – terminating, non –repeating (D) Terminating after two places of decimal

(11) The decimal expansion of $\frac{189}{125}$ will terminate after []

- (A) 1 place of decimal (B) 2 places of decimal
(C) 3 places of decimal (D) 4 places of decimal

(12) If $a= 2^3 \times 3$, $b= 2 \times 3 \times 5$, $c= 3^n \times 5$ and LCM (a, b, c) = $2^3 \times 3^2 \times 5$, then n = []

- (A) 1 (B) 2 (C) 3 (D) 4

(13) If n is any natural number, then $6^n - 5^n$ always ends with..... []

- (A) 1 (B) 3 (C) 5 (D) 7

(14) If $\log_2 16 = x$ then x= []

- (A) 1 (B) 2 (C) 3 (D) 4

(15) The standard base of a logarithm is..... []

- (A) 1 (B) 0 (C) 10 (D) 2

(16) If $\log_{10} 2 = 0.3010$, then $\log_{10} 8 =$ []

- (A) 0.3010 (B) 0.9030 (C) 2.4080 (D) None

(17) $\log_{10} 0.01 =$ []

- (A) -2 (B) -1 (C) 1 (D) 2

(18) The exponential form $\log_4 64 = 3$ is []

- (A) $3^4 = 64$ (B) $64^3 = 4$ (C) $4^3 = 64$ (D) None

(19) $\log 15 =$ []

- (A) $\log 3 \cdot \log 5$ (B) $\log 3 + \log 5$ (C) $\log 10 + \log 5$ (D) None

(20) The prime factorization of 216 is []

- (A) $2^2 \times 3^2$ (B) $2^3 \times 3^2$ (C) $2^3 \times 3^3$ (D) $2^4 \times 3$

Key:

1. D 2. D 3. B 4. B 5. A 6. C 7. B 8. A 9. C 10. B
11. C 12. B 13. A 14. D 15. C 16. B 17. B 18. C 19. B 20. C

Fill In the Blanks

- (1) HCF of 4 and 19 is**1**.....
- (2) LCM of 10 and 3 is**30**.....
- (3) If the HCF of two numbers is '1', then the two numbers are called **Co-Prime**.
- (4) If the positive numbers a and b are written as $a = x^5 y^2$, $b = x^3 y^3$, where x and y are prime numbers then the HCF (a, b), LCM(a, b) = **$x^3 y^2, x^5 y^3$**
- (5) The product of two irrational number is **Sometimes rational , Sometimes irrational.**
- (6) $43.\overline{1234}$ is **a rational** number.
- (7) $\log a^p \cdot b^q =$ **$p \log a + q \log b$**
- (8) If $5^3 = 125$, then the logarithm form **$\log_5 125 = 3$**
- (9) $\log_7 343 =$ **3**
- (10) $\log_{2015} 2015 =$ **1**

Tangents and Secants to the Circle

A Line and a circle: let us consider a circle and line say AB. There can be three possibilities given as follows.

- a) **Non-intersecting line:** The line AB and the circle have no common point. In this case, AB is called a “non-intersecting line” with respect to the circle.

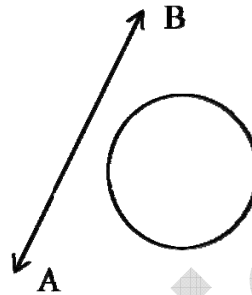

- b) **Tangent:** There is only one point P which is common to the line AB and the circle. In this case, AB is called a “tangent” to the circle and the point P is called the point of contact.

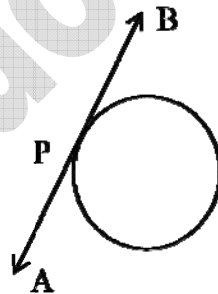

- c) **Secant:** There are two points P and Q which are common to the line AB and the circle. In this case, AB is said to be a “secant” of the circle.

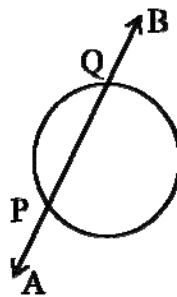

→ The word tangent comes from the latin word “tangere”, which means to touch and was introduced by Danish mathematician “**Thomas finke**” in 1583. The term secant is derived from latin word secare which means to cut.

→ **Tangent of a circle:**

- i) A tangent to a circle is a line that intersects the circle at only one point.
- ii) There is only one tangent at a point of the circle.
- iii) We can draw any number of tangents to a circle.
- iv) We can draw only two tangents to a circle from a point away from the circle.
- v) A tangent is said to touch the circle at the common point.

→ **Theorem(1):** The tangent at any point of a circle is perpendicular to the radius through the point of contact.

→ **Theorem(2):** If a line in the plane is perpendicular to the radius at its end point on the circle, then the line is tangent to the circle.

→ Number of tangents from a circle:

- a) There is no tangent to a circle through a point which lies inside the circle.
- b) There is only one tangent to a circle passing through the point lying on the circle.
- c) There are exactly two tangents to a circle through a point lying outside the circle.

→ **Theorem(3):** The lengths of tangents drawn from an external point to a circle are equal.

→ **Length of tangent:** let P be an external point of a circle centered at ‘O’ with radius ‘r’ and OP=d units. If the point of contact is A, then length of the tangent PA= $\sqrt{(d^2 - r^2)}$

→ **Segment of a circle:**

In a circle, segment is a region bounded by an arc and a chord.

→ Area of segment of a circle= area of the corresponding sector-area of the corresponding triangle.

$$= \frac{x^\circ}{360^\circ} \times \pi r^2 - \text{area of OAB}$$

→ A tangent to a circle intersects it in only one point.

→ A line intersecting a circle in two points is called a secant.

→ A circle can have two parallel tangents at the most.

- The common point of a tangent to a circle is called point of contact.
- We can draw infinite tangents to a given circle.
- The lengths of tangents drawn from an external point to a circle are equal.
- In two concentric circles, such that a chord of the bigger circle, that touches the smaller circle is bisected at the point of contact with the smaller circle.
- IF a circle touches all the four sides of a quadrilateral ABCD at points PQRS, hence
 $AB + CD = BC + DA$
- When the degree measure of the angle at the centre is x° , the area of sector is $\frac{x^\circ}{360^\circ} \times \pi r^2$
- Area of segment of a circle = Area of corresponding sector – area of the corresponding triangles

One Mark Questions

1) Define tangent of a circle.

A line which intersects a circle in only one point is called a tangent to the circle.

2) How many tangents can be drawn from a point outside a circle.

We can draw only two tangents from a point outside a circle.

3) How can you mark the centre of a circle if the circle is given without centre?

We draw any two non parallel chords and again draw the perpendicular bisectors of the chords. The intersecting point of the two perpendicular bisectors is the centre of the circle.

4) Calculate the length of a tangent from a point 13cm away from the centre of a circle of radius 5cm.

Here $r = 5\text{cm}$ and $d = 13\text{cm}$

$$\begin{aligned}\text{Length of tangent} &= \sqrt{d^2 - r^2} \\ &= \sqrt{13^2 - 5^2} \\ &= \sqrt{144} \\ &= 12\end{aligned}$$

5) Write a formula to find area of circle.

$$A = \pi r^2$$

6) Write the formula to find area of regular hexagon.

$$A = 6 \times \frac{\sqrt{3}}{4} \times a^2$$

7) Define normal to the circle at a point.

The line containing the radius through the point of contact is also called the normal to the circle at the point.

8) Write a formula to find area of rectangle.

$$A = l \times b \text{ sq. units}$$

9) Which is the Longest chord of a circle

Diameter

10) What is meant by secant of a circle?

If a line touches the circle at two points then it is called secant of the circle

11) What is meant by point of contact?

The tangent where it touches the circle, that point is called point of contact.

12) How many diameters will be there in a circle?

Infinite

13) How many tangents can be drawn through a point inside a circle?

Zero

www.sakshieducation.com

Short type Questions

1) Two concentric circles having radii 5 cm and 3 cm are drawn. Find the length of the chord of the larger circle which touches the smaller circle.

As shown in the figure

$$OP = 3 \text{ cm}, \quad OB = 5 \text{ cm}$$

Since AB touches the smaller circle at P,

We have OP is perpendicular to AB

$$\angle OPB = 90^\circ$$

By Pythagoras theorem,

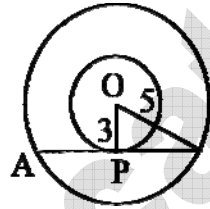

$$OB^2 = OP^2 + PB^2$$

$$PB^2 = OB^2 - OP^2$$

$$= 5^2 - 3^2 = 25 - 9 = 16$$

$$PB = 4 \text{ cm}$$

Since the perpendicular through the center bisects a chord

We have $AP = PB = 4 \text{ cm}$

$$AB = AP + PB = 4 \text{ cm} + 4 \text{ cm} = 8 \text{ cm}$$

Thus, the length of the required chord = 8 cm.

2) A chord of a circle of radius 10 cm. subtends a right angle at the centre. Find the area of the corresponding.

1. Minor segment 2. Major segment

sol: Radius of the circle = 10 cm

$$\angle AOB = 90^\circ$$

$$\text{Area of the } \Delta OAB = \frac{1}{2} \times OA \times OB$$

$$= \frac{1}{2} \times 10 \times 10$$

$$= 50 \text{cm}^2$$

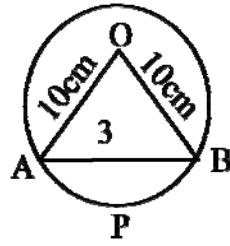

$$\text{Area of sector OAPB} = \frac{x^\circ}{360^\circ} \times \pi r^2$$

$$= \frac{1}{4} \times 314 \text{cm}^2$$

$$= 78.5 \text{cm}^2$$

i) Area of minor segment = area of the sector OAPB - area of ΔOAB

$$= 78.5 \text{cm}^2 - 50 \text{cm}^2$$

$$= 28.5 \text{cm}^2$$

ii) Area of the circle = πr^2

$$= 3.14 \times 10 \text{cm} \times 10 \text{cm}$$

$$= 314 \text{cm}^2$$

Area of the major segment = area of the circle - area of the minor segment

$$= 314 - 28.5$$

$$= 285.5 \text{cm}^2$$

3) A car has two wipers which do not overlap .Each wiper has a blade of length 25 cm. Sweeping through an angle of 115° . Find the total area cleaned at each sweep of the blades.

Sol: We note that the area cleaned by each sweep of the blade of each wiper is equal.

Area swept by each wiper = Area of the sector.

$$= \frac{x^\circ}{360^\circ} \times \pi r^2$$

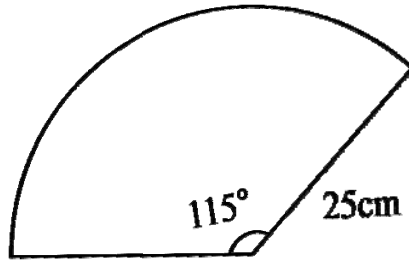

$$= 115^\circ / 360^\circ \times 22/7 \times 25 \times 25 = 158125/252 \text{ cm}^2$$

$$\text{Total area cleaned by both wipers} = 2 \times 158125/252 = 1254.96 \text{ cm}^2$$

4) Find the area of the shaded region in figure, if ABCD is a square of side 10cm and semi circles are drawn with each side of the square as diameter (use $\pi = 3.14$)

Sol: as in figure, let us name the unshaded regions as 1, 2, 3 and 4 from figure, we

observe that area of 1+area of 3

$$= \text{area of ABCD} - \text{areas of two semi circles each of radius 5cm}$$

$$= 10\text{cm} \times 10\text{cm} - 2 \times \frac{1}{2} \times \pi r^2$$

$$= 100\text{cm}^2 - 3.14 \times 5\text{cm} \times 5\text{cm}$$

$$= 100\text{cm}^2 - 78.5\text{cm}^2$$

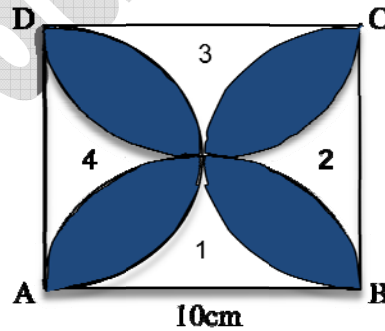

$$= 21.5\text{cm}^2$$

Similarly, area of 2 + area of 4 = 21.5cm²

Area of the shaded part = area of ABCD - area of (1+2+3+4)

$$= (100 - 43)\text{cm}^2$$

$$= 57\text{cm}^2$$

5. Find the area of the shaded region in figure, if ABCD is a square of side 7cm and APD and BPC are semicircles.

Sol: side of the square=7cm

$$\text{Area of the square}=7\times 7=49\text{cm}^2$$

$$\text{Radius of each semicircle}=7/2\text{cm}$$

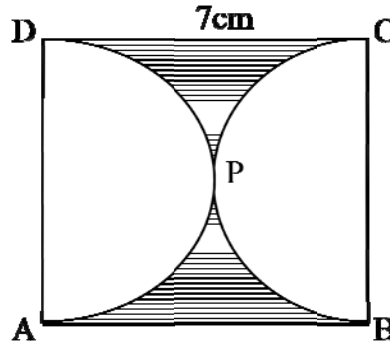

$$\begin{aligned}\text{Area of APD semicircle}&=1/2\times\pi r^2 \\ &=77/4\text{cm}^2\end{aligned}$$

$$\text{Similarly area of BPC semicircle}=77/4\text{cm}^2$$

$$\text{Sum of areas of two semicircles}=38.5\text{cm}^2$$

Area of the shaded part=area of ABCD-sum of areas of semicircles

$$\begin{aligned}&=49^2-38.5^2 \\ &=10.5\text{cm}^2\end{aligned}$$

6) Find the area of sector whose radius is 7cm with the given angle:

60°,30°,72°,90°,120°

$$\text{Sol: If } x^\circ=60^\circ \text{ then area of sector} = \frac{x^\circ}{360^\circ} \times \pi r^2$$

$$= 77/3\text{cm}^2$$

$$\text{If } x^\circ=30^\circ \text{ then area of sector}=77/6\text{cm}^2$$

$$\text{If } x^\circ=90^\circ \text{ then area of sector}=77/2\text{cm}^2$$

$$\text{If } x^\circ=72^\circ \text{ then area of sector}=154/5\text{cm}^2$$

7. Find the length of tangent to a circle with centre 'O' and with its radius 6cm from a point P such that OP = 10cm and the point of contact is A.

Sol: Tangent is perpendicular to the radius at a point of contact

$$\angle OAP = 90^\circ$$

By Pythagoras theorem, $OP^2 = OA^2 + PA^2$

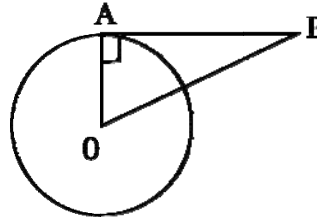

$$PA^2 = OP^2 - OA^2$$

$$= 100 - 36$$

$$= 64$$

$$PA = \sqrt{64}$$

$$= 8\text{cm}$$

8. If two tangents AP and AQ are drawn to a circle with centre O from an external point A then prove $\angle PAQ = 2\angle OPQ$.

Sol: $\angle PAQ = \theta$ say

Clearly $AP = AQ$

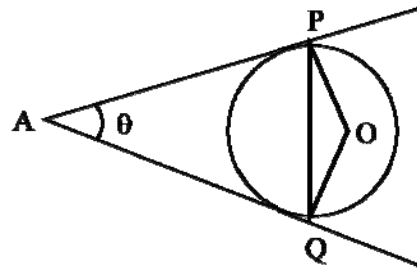

$$\angle APQ = \angle AQP$$

$$\text{But } \angle PAQ + \angle APQ + \angle AQP = 180^\circ$$

$$\angle APQ = \angle AQP = \frac{1}{2}(180^\circ - \theta) = 90^\circ - \frac{1}{2}\theta$$

$$\text{Also } \angle OPQ = \angle OPA - \angle APQ = \frac{1}{2}\theta = \frac{1}{2} \angle PAQ$$

$$\angle OPQ = 1/2 \angle PAQ$$

$$\angle PAQ = 2 \angle OPQ$$

9. If a circle touches all the four sides of a quadrilateral ABCD at points PQRS, then $AB + CD = BC + DA$.

Sol: the two tangents drawn from a point outside to a circle are equal

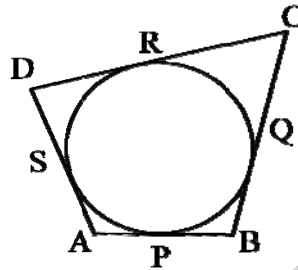

$$AP=AS, BP=BQ, DR=DS, CR=CQ$$

By adding

$$AP+BP+DR+CR=AS+BQ+DS+CQ$$

$$AB+CD=BC+DA$$

Hence proved.

10. If the radius of a circle is 5cm and the angle inclined between the tangents from a point outside is 60° , then what is the distance between the centre and the point outside.

Sol: From the figure, it is given

$$OA=5\text{cm}, \angle APB=60^\circ$$

Clearly OP is an angular bisector of $\angle P$

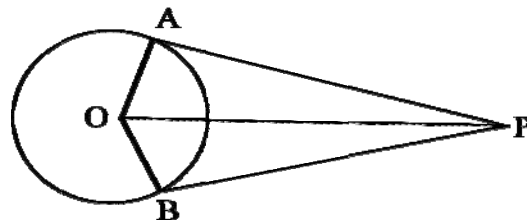

$$\angle APO=30^\circ \text{ and } \angle OAP=90^\circ$$

In ΔOAP we have

$$\sin 30^\circ = OA/OP$$

$$\frac{1}{2} = 5/OP$$

$$OP = 10\text{cm}$$

Essay type Questions

1) Prove that the parallelogram circumscribing a circle is a rhombus.

Sol. Given: ABCD is a parallelogram

$$AB = CD \text{ and } AD = BC \dots\dots\dots(1)$$

The lengths of tangents to a circle from an external point are equal.

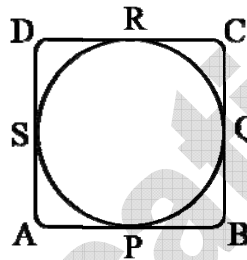

Thus,

$$AS = AP; BQ = BP; CQ = CR; DS = RD$$

By adding, we get

$$AS + BQ + CQ + DS = AP + BP + CR + RD$$

$$AS + DS + BQ + CQ = AP + BP + CR + RD$$

$$AD + BC = AB + CD$$

From (1) we have

$$AD + AD = AB + AB$$

$$2AD = 2AB$$

$$AD = AB \dots\dots\dots(2)$$

From (1) and (2) we have

$$AB = BC = CD = AD$$

ABCD is a rhombus.

Hence proved.

- 2) Construct a tangent to a circle of radius 4 cm from a point on the concentric circles of radius 6 cm and measure its length. Also verify the measurement by actual calculation.**

Steps of construction;

- 1) Draw two concentric circles centred at O with radii 4 cm and 6 cm
- 2) Make any point A on the circle with radius 6 cm
- 3) Join OA and draw a perpendicular bisector to meet OA at C

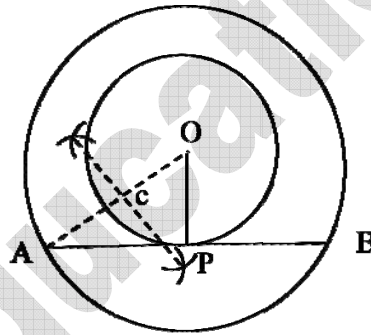

- 4) Centred at c with radius AC draw an arc to cut the circle with radius 4 cm at P. AP is a tangent to the circle with radius 4 cm.

We have AB as tangent to the circle with radius 4 cm and P be the point of contact.

Clearly OP is perpendicular to AB; $\angle OPA = 90^\circ$

By Pythagoras theorem

$$OA^2 = OP^2 + AP^2$$

$$AP^2 = OA^2 - OP^2$$

$$= 6^2 - 4^2 = 36 - 16 = 20$$

$$AP = \sqrt{20} = 2\sqrt{5} = 2 \times 2.236 = 4.472 \text{ cm (app)}$$

We can verify the measurements are both equal.

- 3) In a right angle triangle ABC , a circle with a side AB as diameter is drawn to intersect the hypotenuse AC in P . Prove that the tangent to the circle at P bisects the side BC .

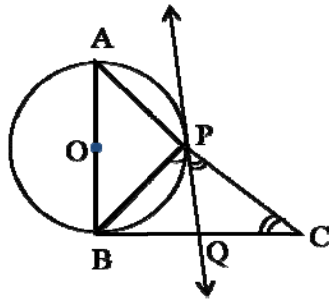

Sol. Given: in

ΔABC , we have $\angle B = 90^\circ$ and AB is the diameter of the circle with centre O . the circle intersect AC in the circle intersect AC in P and the tangent PT at P meets BC in T .

To prove: $TB = TC$

Construction: joint BP

Proof: $\angle APB = 90^\circ$

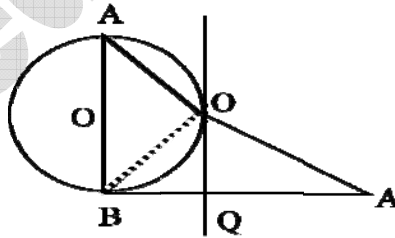

Also $\angle APB + \angle BPC = 180^\circ$

$$90^\circ + \angle BPC = 180^\circ$$

$$\angle BPC = 90^\circ$$

Now $\angle ABC = 90^\circ$

$$\angle BAC + \angle ACB = 90^\circ$$

$$\angle BPC = \angle BAC + \angle ACB$$

$$\angle BPC + \angle CPT = \angle BAC + \angle ACB$$

$$\text{But, } \angle BPT = \angle BAC$$

$$\angle CPT = \angle ACB$$

$$PT = TC$$

$$\text{But } PT = TB$$

$$TB = TC$$

Hence the theorem

- 4) AB and CD are respectively arcs of two concentric circles with radii 21cm and 7cm with centre O. If $\angle AOB=30^\circ$, find the area of the shaded region.**

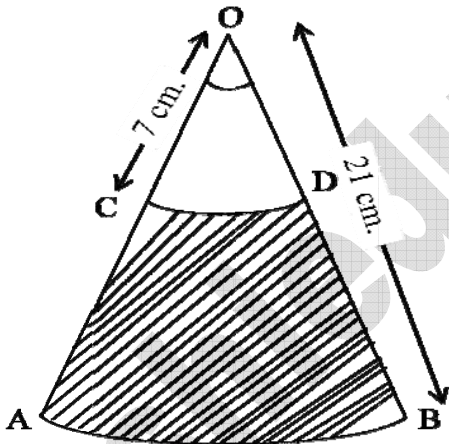

$$\text{Sol: area of the sector OAB} = \frac{x^\circ}{360^\circ} \times \pi r^2$$

$$= 30^\circ/360^\circ \times 22/7 \times 21 \times 21$$

$$= 231/2 \text{ cm}^2$$

$$\text{Area of sector OCD} = \frac{x^\circ}{360^\circ} \times \pi r^2$$

$$= 77/6 \text{ cm}^2$$

$$\text{Area of shaded portion} = \text{area of sector OAB} - \text{area of sector OCD}$$

$$= 231/2 \text{ cm}^2 - 77/6 \text{ cm}^2$$

$= 308\text{cm}^2$

$= 102.67\text{cm}^2$

Bit -Bank

1. The length of the tangents from a point A to a circle of radius 3 cm is 4 cm, then the distance between A and the centre of the circle is _____
2. _____ tangents lines can be drawn to a circle from a point outside the circle.
3. Angle between the tangent and radius drawn through the point of contact is _____
4. A circle may have _____parallel tangents.
5. The common point to a tangent and a circle is called _____
6. A line which intersects the given circle at two distinct points is called a _____ line.
7. Sum of the central angles in a circle is _____
8. The shaded portion represents _____

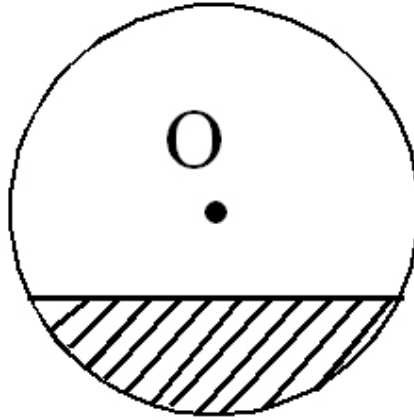

9. If a circle touches all the four sides of an quadrilateral ABCD at points P, Q, R, S then $AB + CD =$ _____
10. If AP and AQ are the two tangents a circle with centre O so that $\angle POQ = 110^\circ$ then $\angle PAQ$ is equal to _____
11. If two concentric circles of radii 5 cm and 3 cm are drawn, then the length of the chord of the larger circle which touches the smaller circle is _____
12. If the semi perimeter of given $\Delta ABC = 28$ cm then $AF+BD+CE$ is _____

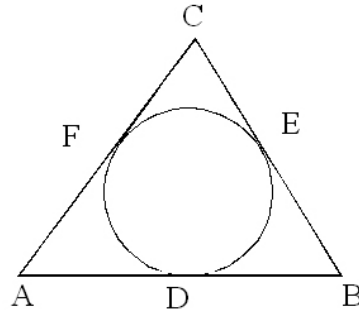

13. The area of a square inscribed in a circle of radius 8cm is ____ cm^2 .
14. Number of circles passing through 3 collinear points in a plane is ____
15. In the figure $\angle BAC$ ____

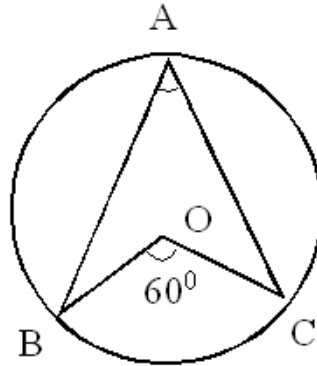

16. If the sector of the circle made an at the centre is x° and radius of the circle is r, then the area of sector is ____
17. If the length of the minute hand of a clock is 14cm, then the area swept by the minute hand in 10 minutes ____
18. If the angle between two radii of a circle is 130° , the angle between the tangents at the ends of the radii is ____
19. If PT is tangent drawn from a point P to a circle touching it at T and O is the centre of the circle, then $\angle OPT + \angle POT$ is ____
20. Two parallel lines touch the circle at points A and B. If area of the circle is $25\pi\text{cm}^2$, then AB is equal to ____
21. A circle have ____ tangents.
22. A quadrilateral PQRS is drawn to circumscribe a circle. If PQ, QR, RS (in cm) are 5, 9, 8 respectively, then PS (in cms) equal to ____
23. From the figure $\angle ACB =$ ____

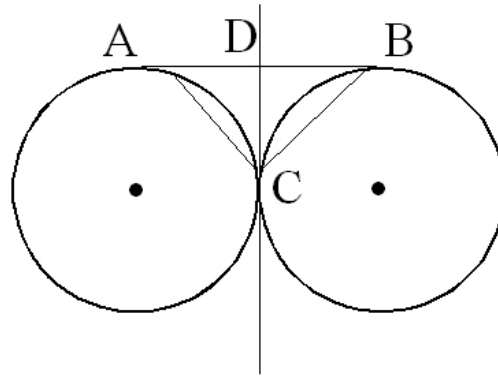

Answers:

- 1) 5cm; 2) 2; 3) 90° ; 4) 2; 5) Point of contact; 6) Secant line; 7) 360° ; 8) Minor segment; 9) $BC + AD$; 10) 70° ; 11) 8 cm; 12) 28cm; 13) 128; 14) 1; 15) 30° ; 16) $\frac{x^\circ}{360} \times \pi r^2$; 17) $102\frac{2}{3}$; 18) 50° ; 19) 90° ; 20) 10cm; 21) Infinitely many; 22) 4cm; 23) 90° ; 24) 65° ; 25) $2\sqrt{a^2 - b^2}$; 26) 6cm; 27) 2cm; 28) equal.

Chapter -7

Coordinate Geometry

1 Mark Questions

1. **Where do these following points lie (0, -3), (0, -8), (0, 6), (0, 4)**

A. Given points (0, -3), (0, -8), (0, 6), (0, 4)

The x- coordinates of each point is zero.

∴ Given points are on the y-axis.

2. **What is the distance between the given points?**

(1) (-4, 0) and (6, 0)

(2) (0, -3), (0, -8)

A. 1) **Given points (-4, 0), (6, 0)**

Given points lie on x-axis (∵ y-coordinates = 0)

∴ The distance between two points = $|x_2 - x_1|$
 $= |6 - (-4)| = 10$

2) **Given points (0, -3), (0, -8)**

Given points lie on y - axis (∵ x-coordinates = 0)

∴ The distance between two points = $|y_2 - y_1|$
 $= |-8 - (-3)| = 5$

3. **Find the distance between the following pairs of points**

(i) (-5, 7) and (-1, 3)

(ii) (a, b) and (-a, -b)

A. Distance between the points (x_1, y_1) and (x_2, y_2)

$$= \sqrt{(x_2 - x_1)^2 + (y_2 - y_1)^2}$$

i) Distance between the points (-5, 7) and (-1, 3)

$$= \sqrt{(-1 - (-5))^2 + (3 - 7)^2} = \sqrt{4^2 + (-4)^2}$$

$$= \sqrt{16 + 16} = \sqrt{32} = 4\sqrt{2}$$

ii) Distance between (a, b) and (-a, -b)

$$= \sqrt{(-a - a)^2 + (-b - b)^2} = \sqrt{(-2a)^2 + (-2b)^2} = \sqrt{4a^2 + 4b^2}$$

$$= \sqrt{4(a^2 + b^2)} = 2\sqrt{a^2 + b^2}$$

4. Find the radius of the circle whose centre is (3, 2) and passes through (-5, 6)

A.

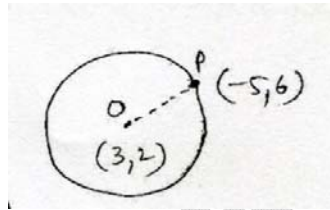

Let the centre 'O' = (3, 2)

The point on the circle p = (-5, 6)

Radius of the circle = distance between the points O (3, 2) and p (-5, 6)

$$= \sqrt{(-5 - 3)^2 + (6 - 2)^2} = \sqrt{64 + 16} = \sqrt{80}$$

$$= \sqrt{16 \times 5} = 4\sqrt{5} \text{ units}$$

5. Find the values of y for which the distance between the points P (2, -3) and Q(10, y) is 10 units.

A. Given points P (2, -3) and Q (10, y)

Given that PQ = 10 units

$$\text{i.e. } = \sqrt{(10 - 2)^2 + (y - (-3))^2} = 10$$

$$8^2 + (y + 3)^2 = 10^2 \Rightarrow 64 + (y + 3)^2 = 100$$

$$(y + 3)^2 = 100 - 64 \Rightarrow (y + 3)^2 = 36 \Rightarrow y + 3 = \sqrt{36} = \pm 6$$

$$y = \pm 6 - 3; y = 6 - 3 \text{ or, } y = -6 - 3 \Rightarrow y = 3, \text{ or } -9$$

Hence, the required value of y is 3 or -9.

6. Find the distance between the points $(a \sin \alpha, -b \cos \alpha)$ and $(-a \cos \alpha, b \sin \alpha)$

A. Distance between the points (x_1, y_1) and (x_2, y_2) is

$$= \sqrt{(x_2 - x_1)^2 + (y_2 - y_1)^2}$$

Similarly the distance between $(a \sin \alpha, -b \cos \alpha)$ and $(-a \cos \alpha, b \sin \alpha)$

$$= \sqrt{(-a \cos \alpha - a \sin \alpha)^2 + (b \sin \alpha - (-b \cos \alpha))^2}$$

$$= \sqrt{a^2 (\cos \alpha + \sin \alpha)^2 + b^2 (\sin \alpha + \cos \alpha)^2}$$

$$= \sqrt{(a^2 + b^2)(\sin \alpha + \cos \alpha)^2}$$

$$= (\sqrt{a^2 + b^2})(\sin \alpha + \cos \alpha)$$

7. Find the coordinates of the point which divides the join of $(-1, 7)$ and $(4, -3)$ in the ratio 2:3

A. Given points $(-1, 7)$ and $(4, -3)$

Given ratio $2 : 3 = m_1 : m_2$

Let $p(x, y)$ be the required point.

Using the section formula

$$p(x, y) = \left(\frac{m_1 x_2 + m_2 x_1}{m_1 + m_2}, \frac{m_1 y_2 + m_2 y_1}{m_1 + m_2} \right)$$

$$= \left(\frac{(2)(4) + (3)(-1)}{2 + 3}, \frac{(2)(-3) + (3)(7)}{2 + 3} \right)$$

$$= \left(\frac{8 - 3}{5}, \frac{-6 + 21}{5} \right) = \left(\frac{5}{5}, \frac{15}{5} \right) = (1, 3)$$

8. If A and B are $(-2, -2)$ and $(2, -4)$ respectively. Find the coordinates of p such that $AP = \frac{3}{7} AB$ and p lies on the segment AB

A. We have $AP = \frac{3}{7} AB \Rightarrow \frac{AP}{AB} = \frac{3}{7}$

Image

$$\frac{AP}{AP+PB} = \frac{3}{7} \quad (\because AB = AP + PB)$$

$$7AP = 3(AP + PB) \Rightarrow 7AP - 3AP = 3PB \Rightarrow 4AP = 3PB$$

$$\Rightarrow \frac{AP}{PB} = \frac{3}{4}$$

So p divides AB in the ratio = 3 : 4

$$A = (-2, -2); B = (2, -4)$$

$$\therefore \text{Coordinates of P are } \left(\frac{(3)(2) + (4)(-2)}{3+4}, \frac{(3)(-4) + (4)(-2)}{3+4} \right)$$

$$P(x, y) = \left(\frac{6-8}{7}, \frac{-12-8}{7} \right) = \left(\frac{-2}{7}, \frac{-20}{7} \right)$$

9. If the mid-point of the line segment joining $A \left[\frac{x}{2}, \frac{y+1}{2} \right]$ and

B $(x + 1, y - 3)$ is C $(5, -2)$, find x, y

A. Midpoint of the line segment joining A (x_1, y_1) , B (x_2, y_2) is $\left(\frac{x_1 + x_2}{2}, \frac{y_1 + y_2}{2} \right)$

Given that midpoint of $A \left[\frac{x}{2}, \frac{y+1}{2} \right]$ and B $(x + 1, y - 3)$ is C $(5, -2)$

$$\therefore (5, -2) = \left(\frac{\frac{x}{2} + x + 1}{2}, \frac{\frac{y+1}{2} + y - 3}{2} \right)$$

$$\frac{\frac{x}{2} + x + 1}{2} = 5 \Rightarrow \frac{x + 2x + 2}{4} = 5$$

$$\Rightarrow 3x + 2 = 20 \Rightarrow x = 6$$

$$\frac{\frac{y+1}{2} + (y-3)}{2} = -2 \Rightarrow \frac{y+1+2y-6}{4} = -2$$

$$\Rightarrow 3y - 5 = -8 \Rightarrow y = -1$$

$$\therefore x = 6, y = -1$$

10. The points (2, 3), (x, y), (3, -2) are vertices of a triangle. If the centroid of this triangle is origin, find (x, y)

A. Centroid of $(x_1, y_1), (x_2, y_2)$ and $(x_3, y_3) = \left(\frac{x_1 + x_2 + x_3}{3}, \frac{y_1 + y_2 + y_3}{3} \right)$

Given that centroid of (2, 3), (x, y), (3, -2) is (0, 0)

$$\text{i.e. } (0,0) = \left(\frac{2+x+3}{3}, \frac{3+y-2}{3} \right)$$

$$(0,0) = \left(\frac{5+x}{3}, \frac{y+1}{3} \right)$$

$$\frac{5+x}{3} = 0 \Rightarrow x = -5$$

$$\frac{y+1}{3} = 0 \Rightarrow y = -1$$

11. If the points A (6, 1), B (8, 2), C (9, 4) and D (P, 3) are the vertices of a parallelogram, taken in order find the value of p.

A. We know that diagonals of parallelogram bisect each other. Given A (6, 1), B (8, 2), C (9, 4), D (P, 3)

So, the coordinates of the midpoint of AC =

Coordinates of the midpoint of BD

$$\text{i.e. } \left(\frac{6+9}{2}, \frac{1+4}{2} \right) = \left(\frac{8+p}{2}, \frac{2+3}{2} \right)$$

$$\Rightarrow \left(\frac{15}{2}, \frac{5}{2} \right) = \left(\frac{8+p}{2}, \frac{5}{2} \right) \Rightarrow \frac{8+p}{2} = \frac{15}{2}$$

$$\Rightarrow p = 15 - 8 = 7.$$

12. Find the area of the triangle whose vertices are (0, 0), (3, 0) and (0, 2)

A. Area of triangle $\Delta = \frac{1}{2} |x_1(y_2 - y_3) + x_2(y_3 - y_1) + x_3(y_1 - y_2)|$

$$\Delta = \frac{1}{2} |0(0-2) + 3(2-0) + 0(0-0)| = \frac{1}{2} |6| = 3 \text{sq units}$$

Note: Area of the triangle whose vertices are (0,0), (x₁, y₁), (x₂, y₂) is

$$\frac{1}{2} |x_1y_2 - x_2y_1|$$

13. Find the slope of the line joining the two points A (-1.4, -3.7) and B (-2.4, 1.3)

A. Given points A (-1.4, -3.7), B (-2.4, 1.3)

$$\text{Slope of } AB = \frac{y_2 - y_1}{x_2 - x_1} = \frac{(1.3) - (-3.7)}{-2.4 - (-1.4)} = \frac{1.3 + 3.7}{-2.4 + 1.4} = \frac{5}{-1} = -5$$

14. Justify that the line \overline{AB} line segment formed by (-2, 8), (-2,-2) is parallel to y-axis. What can you say about their slope? Why?

A. Slope of $AB = \frac{y_2 - y_1}{x_2 - x_1} = \frac{-2 - 8}{(-2) - (-2)} = \frac{-10}{0} = \text{undefined}$

The slope of AB cannot be defined, because the line segment \overline{AB} is parallel to y-axis.

15. If $x - 2y + k = 0$ is a median of the triangle whose vertices are at points A (-1,3), B (0,4) and C (-5, 2), find the value of K.

A. The coordinates of the centroid G of ΔABC

$$= \left(\frac{(-1) + 0 + (-5)}{3}, \frac{3 + 4 + 2}{3} \right) = (-2, 3)$$

Since G lies on the median $x - 2y + k = 0$,

\Rightarrow Coordinates of G satisfy its equation

$$\therefore -2 - 2(3) + K = 0 \Rightarrow K = 8.$$

16. Determine x so that 2 is the slope of the line through P (2, 5) and Q (x, 3)

A. Given points P (2, 5) and Q (x, 3)

Slope of \overline{PQ} is 2

$$\therefore \text{slope} = 2 = \frac{y_2 - y_1}{x_2 - x_1} = \frac{3 - 5}{x - 2} = \frac{-2}{x - 2}$$

$$\Rightarrow \frac{-2}{x - 2} = 2 \Rightarrow -2 = 2(x - 2)$$

$$\Rightarrow -2 = 2x - 4 \Rightarrow 2x = 2 \Rightarrow x = 1.$$

17. The coordinates of one end point of a diameter of a circle are (4, -1) and the coordinates of the centre of the circle are (1, -3). Find the coordinates of the other end of the diameter.

A. Let AB be a diameter of the circle having its centre at C (1, -3) such that the coordinates of one end A are (4, -1)

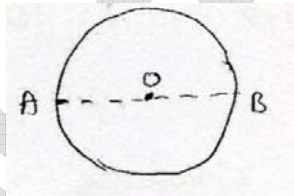

Let the coordinates of other end be B (x, y) since C is the mid-point of AB.

$$\therefore \text{The coordinates of C are } \left(\frac{x+4}{2}, \frac{y-1}{2} \right)$$

But, the coordinates of C are given to be (1, -3)

$$\therefore \left(\frac{x+4}{2}, \frac{y-1}{2} \right) = (1, -3) \Rightarrow \frac{x+4}{2} = 1 \Rightarrow x = -2$$

$$\frac{y-1}{2} = -3 \Rightarrow y = -5$$

The other end point is (-2, -5).

2 Mark Questions

1. Find a relation between x and y such that the point (x, y) is equidistant from the points (-2, 8) and (-3, -5)

A. Let P(x, y) be equidistant from the points A (-2, 8) and B (-3, -5)

$$\text{Given that } AP = BP \Rightarrow AP^2 = BP^2$$

$$\text{i.e. } (x - (-2))^2 + (y - 8)^2 = (x - (-3))^2 + (y - (-5))^2$$

$$\text{i.e. } (x + 2)^2 + (y - 8)^2 = (x + 3)^2 + (y + 5)^2$$

$$x^2 + 4x + 4 + y^2 - 16y + 64 = x^2 + 6x + 9 + y^2 + 10y + 25$$

$$-2x - 26y + 68 - 34 = 0$$

$$-2x - 26y = -34$$

Model problem: Find $x + 13y = 17$, Which is the required relation. A relation between x and y such that the point (x, y) is equidistant from the point (7, 1) and (3, 5)

2. Find the point on the x – axis which is equidistant from (2, -5) and (-2, 9)

A. We know that a point on the x-axis is of the form (x, 0). So, let the point P(x, 0) be equidistant from A (2, -5), and B (-2, 9)

$$\text{Given that } PA = PB$$

$$PA^2 = PB^2$$

$$(x - 2)^2 + (0 - (-5))^2 = (x - (-2))^2 + (0 - 9)^2$$

$$x^2 - 4x + 4 + 25 = x^2 + 4x + 4 + 81$$

$$-4x - 4x + 29 - 85 = 0$$

$$-8x - 56 = 0$$

$$x = -\frac{56}{8} = -7$$

So, the required point is (-7, 0)

Model problem:

Find a point on the y –axis which is equidistant from both the points A (6, 5) and B (–4, 3)

3. Verify that the points (1, 5), (2, 3) and (–2, –1) are collinear or not

A. Given points let A (1, 5), B (2, 3) and C (–2, –1)

$$\overline{AB} = \sqrt{(2-1)^2 + (3-5)^2} = \sqrt{1+4} = \sqrt{5}$$

$$\overline{BC} = \sqrt{(-2-2)^2 + (-1-3)^2} = \sqrt{16+16} = \sqrt{32} = 4\sqrt{2}$$

$$\overline{CA} = \sqrt{(5-(-1))^2 + (1-(-2))^2} = \sqrt{36+9} = \sqrt{45} = 3\sqrt{5}$$

We observe that $AB + BC \neq CA$

∴ Given points are not collinear.

Model Problem: Show that the points A(4, 2), B(7, 5) and C(9, 7) are three points lie on a same line.

Note: we get $AB + BC = AC$, so given points are collinear.

Model problem: Are the points (3, 2), (–2, –3) and (2, 3) form a triangle.

Note: We get $AB + BC \neq AC$, so given points form a triangle.

4. Check whether (5, –2), (6, 4) and (7, –2) are the vertices of an isosceles triangle.

A. Let the points are A (5, –2), B (6, 4) and C (7, –2)

$$AB = \sqrt{(6-5)^2 + (4-(-2))^2} = \sqrt{1+36} = \sqrt{37}$$

$$BC = \sqrt{(7-6)^2 + (-2-4)^2} = \sqrt{1+36} = \sqrt{37}$$

$$CA = \sqrt{(7-5)^2 + (-2+2)^2} = \sqrt{4+0} = 2$$

Since $AB = BC$, Given vertices form an isosceles triangle.

5. In what ratio does the point $(-4, 6)$ divide the line segment joining the points A $(-6, 10)$ and B $(3, -8)$

A. Let $(-4, 6)$ divide AB internally in the ratio $m_1:m_2$ using the section formula, we get

$$\begin{aligned} (-4, 6) &= \left(\frac{3m_1 - 6m_2}{m_1 + m_2}, \frac{-8m_1 + 10m_2}{m_1 + m_2} \right) \\ \Rightarrow \frac{3m_1 - 6m_2}{m_1 + m_2} &= -4 \quad \frac{-8m_1 + 10m_2}{m_1 + m_2} = 6 \\ \Rightarrow 3m_1 - 6m_2 &= -4m_1 - 4m_2 \Rightarrow 7m_1 - 2m_2 = 0 \\ 7m_1 &= 2m_2 \\ \Rightarrow \frac{m_1}{m_2} &= \frac{2}{7} \\ \therefore m_1 : m_2 &= 2 : 7 \end{aligned}$$

Model problem: Find the ratio in which the line segment joining The points $(-3, 10)$ and $(6, -8)$ is divided by $(-1, 6)$.

6. Find the ratio in which the y-axis divides the line segment joining the points $(5, -6)$ and $(-1, -4)$. Also find the point of intersection.

A. Let the ratio be $K : 1$. Then by the section formula, the coordinates of the point which divides AB in the ratio $K : 1$ are $K : 1$ $(5, -6)$ $(-1, -4)$

$$\begin{aligned} &\left(\frac{k(-1) + 1(5)}{k+1}, \frac{k(-4) + 1(-6)}{K+1} \right) \\ &\text{i.e.} \left(\frac{-k+5}{k+1}, \frac{-4k-6}{K+1} \right) \end{aligned}$$

This point lies on the y-axis, and we know that on the y-axis the x coordinate is 0

$$\therefore \frac{-k+5}{K+1} = 0 \Rightarrow -k+5=0 \Rightarrow k=5$$

So the ratio is $K : 1 = 5 : 1$

Putting the value of $k = 5$, we get the point of intersection as

$$\left(\frac{-5+5}{5+1}, \frac{-4(5)-6}{5+1}\right) = \left(0, \frac{-26}{6}\right) = \left(0, \frac{-13}{3}\right)$$

7. If (1, 2), (4, y), (x, 6) and (3, 5) are the vertices of a parallelogram taken in order, find x and y.

A. Let the Given points A (1, 2), B (4, y), C (x, 6) and D (3, 5) are the vertices of a parallelogram.

We know that diagonals of parallelogram bisect each other

\therefore Midpoint of AC = Midpoint of BD.

$$\left(\frac{1+x}{2}, \frac{2+6}{2}\right) = \left(\frac{4+3}{2}, \frac{y+5}{2}\right)$$

$$\Rightarrow \frac{1+x}{2} = \frac{4+3}{2} \Rightarrow \frac{1+x}{2} = \frac{7}{2} \Rightarrow 1+x=7 \Rightarrow x=6$$

$$\frac{y+5}{2} = \frac{2+6}{2} \Rightarrow y+5=8 \Rightarrow y=3$$

$$\therefore x = 6, y = 3$$

8. Find the area of a triangle whose vertices are (1, -1), (-4, 6) and (-3, -5)

A. Let the points are A (1, -1), B (-4, 6) and C (-3, -5)

$$\text{Area of } \triangle ABC = \frac{1}{2} |x_1(y_2 - y_3) + x_2(y_3 - y_1) + x_3(y_1 - y_2)|$$

$$= \frac{1}{2} |1(6 - (-5)) + (-4)(-5 - (-1)) + (-3)(-1 - 6)|$$

$$= \frac{1}{2} |11 + 16 + 21| = \frac{1}{2} \times 48 = 24 \text{ square units}$$

Model problem:

Find the area of a triangle formed by the points A (3, 1), B (5, 0), C (1, 2)

9. Find the area of the square formed by (0, -1), (2, 1), (0, 3) and (-2, 1) taken in order are as vertices

A. Area of the square

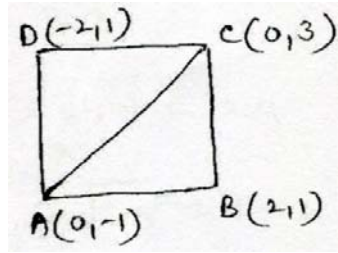

$$= 2 \times \text{area of } \triangle ABC \rightarrow (1)$$

$$\begin{aligned} \text{Area of } \triangle ABC &= \frac{1}{2} |0(1-3) + 2(3+1) + 0(-1-1)| \\ &= 4 \text{ sq.units} \end{aligned}$$

\therefore From eqn (1), we get

$$\text{Area of the given square} = 2 \times 4 = 8 \text{ sq.units.}$$

10. The points (3, -2), (-2, 8) and (0, 4) are three points in a plane. Show that these points are collinear.

A. By using area of the triangle formula

$$\Delta ABC = \frac{1}{2} |x_1(y_2 - y_3) + x_2(y_3 - y_1) + x_3(y_1 - y_2)|$$

Given points A (3, -2), B(-2, 8), C(0, 4)

$$\begin{aligned} \Delta &= \frac{1}{2} |3(8-4) + (-2)(4-(-2)) + 0(-2-8)| \\ &= \frac{1}{2} |12-12+0| = 0 \end{aligned}$$

The area of the triangle is 0. Hence the three points are collinear or they lie on the same line.

4 Marks Questions

1. Show that following points form an equilateral triangle A (a, 0), B(-a, 0), C (0, a√3)

A. Given points A (a, 0), B (-a, 0), C (0, a√3)

Distance between two points

$$\sqrt{(x_2 - x_1)^2 + (y_2 - y_1)^2}$$

$$AB = \sqrt{(-a - a)^2 + (0 - 0)^2} = \sqrt{(2a)^2} = 2a$$

$$BC = \sqrt{(0 - (-a))^2 + (a\sqrt{3} - 0)^2} = \sqrt{a^2 + 3a^2} = \sqrt{4a^2} = 2a$$

$$CA = \sqrt{(0 - a)^2 + (a\sqrt{3} - 0)^2} = \sqrt{a^2 + 3a^2} = \sqrt{4a^2} = 2a$$

Since AB = BC = CA, Given points form an equilateral triangle.

2. Name the type of quadrilateral formed. If any, by the following points, and give reasons for your answer the points are (-3, 5), (3, 1), (0, 3), (-1, -4).

A. Let the Given points A (-3, 5), B(3, 1), C (0, 3), D (-1, -4).

$$AB = \sqrt{(3 - (-3))^2 + (1 - 5)^2} = \sqrt{36 + 16} = \sqrt{52}$$

$$BC = \sqrt{(0 - 3)^2 + (3 - 1)^2} = \sqrt{9 + 4} = \sqrt{13}$$

$$CD = \sqrt{(-1 - 0)^2 + (-4 - 3)^2} = \sqrt{1 + 49} = \sqrt{50}$$

$$DA = \sqrt{(-3 + 1)^2 + (5 + 4)^2} = \sqrt{4 + 81} = \sqrt{85}$$

$$AB \neq BC \neq CD \neq DA$$

∴ The points do not form a quadrilateral

Note: A, B, C and D are four vertices of a quadrilateral

i) If AB = BC = CD = DA and AC = BD, then it is square

ii) If AB = BC = CD = DA and AC ≠ BD, then it is Rhombus

iii) If AB = CD, BC = DA and AC = BD, then it is Rectangular

iv) If $AB = CD$, $BC = DA$ and $AC \neq BD$, then it is parallelogram

v) Any two sides are not equal then it is quadrilateral

3. Prove that the points $(-7, -3)$, $(5, 10)$, $(15, 8)$ and $(3, -5)$ taken in order are the corners of a parallelogram.

A. Given corners of a parallelogram

$A(-7, -3)$, $B(5, 10)$, $C(15, 8)$ $D(3, -5)$

$$AB = \sqrt{(5 - (-7))^2 + (10 - (-3))^2} = \sqrt{144 + 169} = \sqrt{313}$$

$$BC = \sqrt{(15 - 5)^2 + (8 - 10)^2} = \sqrt{100 + 4} = \sqrt{104}$$

$$CD = \sqrt{(3 - 15)^2 + (-5 - 8)^2} = \sqrt{144 + 169} = \sqrt{313}$$

$$DA = \sqrt{(3 + 7)^2 + (-5 + 3)^2} = \sqrt{100 + 4} = \sqrt{104}$$

$$AC = \sqrt{(15 + 7)^2 + (8 + 3)^2} = \sqrt{484 + 121} = \sqrt{605}$$

$$BD = \sqrt{(3 - 5)^2 + (-5 - 10)^2} = \sqrt{4 + 225} = \sqrt{229}$$

Since $AB = CD$, $BC = DA$ and $AC \neq BD$

\therefore ABCD is a parallelogram

4. Given vertices of a rhombus A $(-4, -7)$, B $(-1, 2)$, C $(8, 5)$, D $(5, -4)$

A.

$$AB = \sqrt{(-1 - (-4))^2 + (2 - (-7))^2} = \sqrt{3^2 + 9^2} = \sqrt{9 + 81} = \sqrt{90}$$

$$BC = \sqrt{(8 - (-1))^2 + (5 - 2)^2} = \sqrt{9^2 + 3^2} = \sqrt{90}$$

$$CD = \sqrt{(5 - 8)^2 + (-4 - 5)^2} = \sqrt{9 + 81} = \sqrt{90}$$

$$DA = \sqrt{(-4 - 5)^2 + (-7 + 4)^2} = \sqrt{81 + 9} = \sqrt{90}$$

$$AC = \sqrt{(8 - (-4))^2 + (5 - (-7))^2} = \sqrt{144 + 144} = \sqrt{288}$$

$$BD = \sqrt{(5 - (-1))^2 + (-4 - 2)^2} = \sqrt{36 + 36} = \sqrt{72}$$

Since $AB = BC = CD = DA$ and $AC \neq BD$

\therefore ABCD is a rhombus

Area of rhombus

$$\begin{aligned} &= \frac{1}{2} \times \text{product of diagonals} \\ &= \frac{1}{2} \times \sqrt{288} \times \sqrt{72} = \frac{1}{2} \sqrt{288 \times 72} \\ &= \frac{1}{2} \sqrt{72 \times 4 \times 72} = \frac{1}{2} \times 72 \times 2 = 72 \text{ sq.units} \end{aligned}$$

Model problem: Show that the points A (2, -2), B (14, 10), C (11, 13) and D (-1, 1) are the vertices of a rectangle.

Model Problem: Show the points A (3, 9), B (6, 4), C (1, 1) and D (-2, 6) are the vertices of a square ABCD.

5. Find the coordinates of the points of trisection (The points which divide a line segment into 3 equal part are said to be the trisection points) of the line segment joining the points A (2, -2) and (-7, 4)

(A) Trisection points: The points which divide a line segment into 3 equal parts are said to be the trisection points.

(or)

The points which divide the given line segment in the ratio 1:2 and 2:1 are called points of trisection.

A.

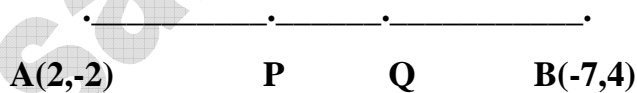

Let P and Q be the points of trisection of AB i.e. $AP = PQ = QB$.

Therefore, P divides AB internally in the ratio 1:2

By applying the section formula $m_1:m_2 = 1:2$

$$p(x, y) = \left(\frac{m_1x_2 + m_2x_1}{m_1 + m_2}, \frac{m_1y_2 + m_2y_1}{m_1 + m_2} \right)$$

$$= \left(\frac{(1)(-7) + (2)(2)}{1+2}, \frac{(1)(4) + (2)(-2)}{1+2} \right) = (-1, 0)$$

Q divides AB internally in the ratio 2:1

$$Q(x, y) = \left(\frac{(2)(-7) + (1)(2)}{2+1}, \frac{(2)(4) + (1)(-2)}{2+1} \right) = \left(\frac{-12}{3}, \frac{6}{3} \right) = (-4, 2)$$

∴ The coordinates of the points of trisection of the line segment are p (-1, 0) and Q (-4, 2)

Model problem: Find the trisection points of line joining (2, 6) and (-4, 3)

6. Find the coordinates of the points which divides the line segment joining A (-2, 2) and B (2, 8) into four equal parts.

A. Given points A (-2, 2) and B (2, 8)

Let P, Q, R divides \overline{AB} into four equal parts

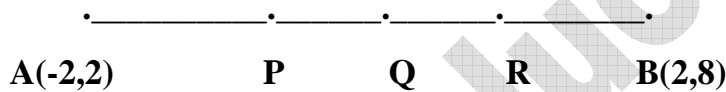

A (-2, 2) B (2, 8)

P divides \overline{AB} in the ratio 1:3

$$p(x, y) = \left(\frac{m_1x_2 + m_2x_1}{m_1 + m_2}, \frac{m_1y_2 + m_2y_1}{m_1 + m_2} \right)$$

$$= \left(\frac{(1)(2) + (3)(2)}{1+3}, \frac{(1)(8) + (3)(2)}{1+3} \right) = \left(-1, \frac{7}{2} \right)$$

Q divides \overline{AB} in the ratio 2:2= 1:1

i.e Q is the midpoint of AB

$$Q(x, y) = \left(\frac{x_1 + x_2}{2}, \frac{y_1 + y_2}{2} \right) = \left(\frac{-2+2}{2}, \frac{2+8}{2} \right) = (0, 5)$$

R divides \overline{AB} in the ratio 3:1

$$R(x, y) = \left(\frac{(3)(2) + (1)(-2)}{3+1}, \frac{(3)(8) + (1)(2)}{3+1} \right) = \left(\frac{4}{4}, \frac{26}{4} \right) = \left(1, \frac{13}{2} \right)$$

∴ The points divide \overline{AB} into four equal parts are $P\left(-1, \frac{7}{2}\right), Q(0, 5), R\left(1, \frac{13}{2}\right)$

Model Problem: Find the coordinates of points which divide the line segment joining A (-4, 0) and B (0, 6) into four equal parts.

7. Find the area of the quadrilateral whose vertices taken in order, are (-4, -2), (-3, -5), (3, -2) and (2, 3)

A. Let the given vertices of a quadrilateral are A(-4, -2), B (-3, -5), C (3, -2) D(2, 3)

Area of quadrilateral ABCD = Area of ΔABC + Area of ΔACD

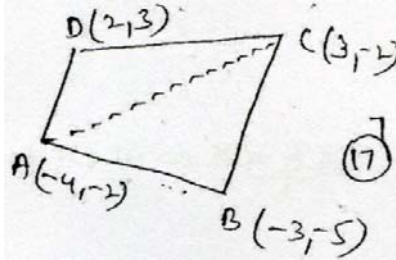

Area of ΔABC

A(-4, 2), B(-3, -5), C(3, -2)

$$\begin{aligned} \text{Area of } \Delta ABC &= \frac{1}{2} |-4(-5 - (-2)) + (-3)((-2) - (-2)) + 3(-2 - (-5))| \\ &= \frac{1}{2} |(-4)(-3) + (-3)(0) + (3)(3)| = \frac{1}{2} |12 + 9| = \frac{21}{2} = 10.5 \text{ sq. units} \end{aligned}$$

Area of ΔACD

A(-4, 2), B(3, -2), C(2, 3)

$$\begin{aligned} \text{Area of } \Delta ABC &= \frac{1}{2} |-4(-2 - 3) + (3)(3 - (-2)) + 2(-2 - (-2))| \\ &= \frac{1}{2} |20 + 15 + 0| = \frac{35}{2} = 17.5 \text{ sq. units} \end{aligned}$$

Area of quadrilateral ABCD = Ar (ΔABC) + Ar (ΔACD)

$$= 10.5 + 17.5 = 28 \text{ sq. units}$$

Model problem: If A (-5, 7), B (-4, -5), C(-1, -6) and D (4, 5)

Are the vertices of a quadrilateral. Then find the area of the quadrilateral ABCD.

8. Find the value of 'K' for which the points (k, k) (2,3) and (4, -1) are collinear

A. Let the given points A (k, k), B (2, 3), C (4, -1)

If the points are collinear then the area of $\Delta ABC = 0$.

$$\therefore \frac{1}{2} |x_1(y_2 - y_3) + x_2(y_3 - y_1) + x_3(y_1 - y_2)| = 0$$

$$\therefore \frac{1}{2} |k(3 - (-1)) + 2(-1 - k) + 4(k - 3)| = 0$$

$$\therefore \frac{1}{2} |4k - 2 - 2k + 4k - 12| = 0$$

$$|6k - 14| = 0 \Rightarrow 6k - 14 = 0 \Rightarrow 6k = 14$$

$$k = \frac{14}{6} = \frac{7}{3}$$

Model problem: Find the value of 'k' for which the points (7, -2), (5, 1), (3, k) are collinear

Model Problem: Find the value of 'b' for which the points

A (1, 2), B (-1, b), C (-3, -4) are collinear.

9. Find the area of the triangle formed by the points (0,0), (4, 0), (4, 3) by using Heron's formula.

A. Let the given points be A (0, 0), B (4, 0), C (4, 3)

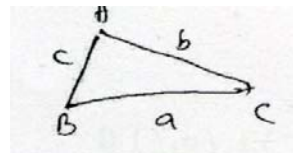

Let the lengths of the sides of ΔABC are a, b, c

$$a = \overline{BC} = \sqrt{(4-4)^2 + (3-0)^2} = \sqrt{0+9} = 3$$

$$b = \overline{CA} = \sqrt{(4-0)^2 + (3-0)^2} = \sqrt{16+9} = 5$$

$$c = \overline{AB} = \sqrt{(4-0)^2 + (0-0)^2} = 4$$

$$S = \frac{a+b+c}{2} = \frac{3+5+4}{2} = 6$$

Heron's formula

$$\begin{aligned} \text{Area of } \Delta ABC &= \sqrt{s(s-a)(s-b)(s-c)} = \sqrt{6(6-3)(6-5)(6-4)} \\ &= \sqrt{6(3)(1)(2)} = 6 \text{ sq.units.} \end{aligned}$$

10. Find the area of the triangle formed by joining the mid-points of the sides of the triangle whose vertices are (0, -1), (2, 1) and (0, 3). Find the ratio of this area to the area of the given triangle.

A. Let the given points of the triangle of the triangle A (0, -1), B (2, 1) and C (0, 3).

Let the mid-points of AB, BC, CA are D, E, F

$$D = \left(\frac{0+2}{2}, \frac{-1+1}{2} \right) = (1, 0)$$

$$E = \left(\frac{2+0}{2}, \frac{1+3}{2} \right) = (1, 2)$$

$$F = \left(\frac{0+0}{2}, \frac{3-1}{2} \right) = (0, 1)$$

$$\text{Area of } \Delta ABC = \frac{1}{2} |x_1(y_2 - y_3) + x_2(y_3 - y_1) + x_3(y_1 - y_2)|$$

A (0, -1), B (2, 1), C (0, 3).

$$= \frac{1}{2} |0(1-3) + 2(3-(-1)) + 0(-1-1)| = \frac{1}{2} |8| = 4 \text{ sq.units}$$

$$\text{Area of } \Delta DEF = \frac{1}{2} |1(2-1) + 1(1-0) + 0(0-2)|$$

D (1, 0), E (1, 2), F(0, 1)

$$= \frac{1}{2} |2+0| = \frac{1}{2} \times 2 = 1 \text{ sq.units}$$

Ratio of the ΔABC and $\Delta DEF = 4 : 1$

11. Find the area of the square formed by (0, -1), (2, 1), (0, 3) and (-2, 1)

A. In a square four sides are equal

Length of a side of the square

Area of the square = side \times side

$$= \sqrt{8} \times \sqrt{8}$$

$$= 8 \text{ sq. units.}$$

12. Find the coordinates of the point equidistant from. Three given points

A (5, 1), B (-3, -7) and C (7, -1)

A. Let $p(x, y)$ be equidistant from the three given points A(5, 1), B (-3, -7) and C(7, -1)

Then $PA = PB = PC \Rightarrow PA^2 = PB^2 = PC^2$

$$PA^2 = PB^2 \Rightarrow (x - 5)^2 + (y - 1)^2 = (x + 3)^2 + (y + 7)^2$$

$$\Rightarrow x^2 - 10x + 25 + y^2 - 2y + 1 = x^2 + 6x + 9 + y^2 + 14y + 49$$

$$\Rightarrow -16x - 16y + 26 - 58 = 0$$

$$\Rightarrow -16x - 16y - 32 = 0$$

$$\Rightarrow x + y + 2 = 0 \rightarrow (1)$$

$$PB^2 = PC^2 \Rightarrow (x + 3)^2 + (y + 7)^2 = (x - 7)^2 + (y + 1)^2$$

$$\Rightarrow x^2 + 6x + 9 + y^2 + 14y + 49 = x^2 - 14x + 49 + y^2 + 2y + 1$$

$$\Rightarrow 6x + 14x + 14y - 2y + 58 - 50 = 0$$

$$20x + 12y + 8 = 0$$

$$5x + 3y + 2 = 0 \rightarrow (2)$$

Solving eqns (1) & (2)

From (1) $x + y + 2 = 0 \Rightarrow x = -y - 2$

$$y = -4$$

$$(1) \times 3 \quad 3x + 3y + 6 = 0$$

$$(2) \times 1 \quad 5x + 3y + 2 = 0$$

$$\begin{array}{r} - \quad - \quad - \\ -2x \quad + 4 = 0 \end{array}$$

$$x = \frac{-4}{-2} = 2$$

Hence, The required point is (2, -4)

13. Prove that the points (a, b + c), (b, c + a) and (c, a + b) are collinear.

A. Let the given points A (a, b + c), B (b, c + a), C (c, a + b)

$$\begin{aligned} \text{Area of } \Delta ABC &= \frac{1}{2} |x_1(y_2 - y_3) + x_2(y_3 - y_1) + x_3(y_1 - y_2)| \\ &= \frac{1}{2} |a((c+a) - (a+b)) + b((a+b) - (b+c)) + c((b+c) - (c+a))| \\ &= \frac{1}{2} |a(c-b) + b(a-c) + c(b-a)| \\ &= \frac{1}{2} |ac - ab + ba - bc + cb - ca| \\ &= \frac{1}{2} |0| = 0 \end{aligned}$$

Since area of $\Delta ABC = 0$, the given points are collinear.

14. A (3, 2) and B (-2, 1) are two vertices of a triangle ABC, Whose centroid G

has a coordinates $\left(\frac{5}{3}, -\frac{1}{3}\right)$. Find the coordinates of the third vertex c of the triangle.

A. Given points are A (3, 2) and B (-2, 1)

Let the coordinates of the third vertex be C(x, y)

$$\text{Centroid of ABC, } \left(\frac{5}{3}, -\frac{1}{3}\right)$$

$$G = \left(\frac{x_1 + x_2 + x_3}{3}, \frac{y_1 + y_2 + y_3}{3}\right)$$

$$\left(\frac{5}{3}, -\frac{1}{3}\right) = \left(\frac{3+(-2)+x}{3}, \frac{2+1+y}{3}\right)$$

$$\left(\frac{5}{3}, -\frac{1}{3}\right) = \left(\frac{x+1}{3}, \frac{y+3}{3}\right)$$

$$\frac{x+1}{3} = \frac{5}{3} \Rightarrow x+1=5 \Rightarrow x=5-1=4$$

$$\frac{y+3}{3} = -\frac{1}{3} \Rightarrow y+3=-1 \Rightarrow y=-1-3=-4$$

∴ The third vertex is (4, -4)

15. The two opposite vertices of a square are (-1, 2) and (3, 2). Find the coordinates of the other two vertices.

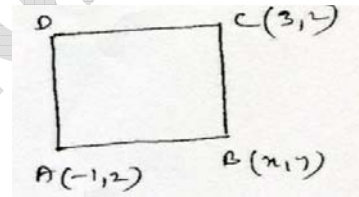

- A. Let the opposite vertices of a square A (-1, 2), C (3, 2)

Let B (x, y) be the unknown vertex

$$AB = BC$$

(∵ In a square sides are equal)

$$\Rightarrow AB^2 = BC^2$$

$$(x - (-1))^2 + (y - 2)^2 = (3 - x)^2 + (2 - y)^2$$

$$\Rightarrow x^2 + 2x + 1 + y^2 - 4y + 4 = 9 + x^2 - 6x + 4 + y^2 - 4y$$

$$\Rightarrow 8x = 13 - 5 \Rightarrow x = 1 \rightarrow (1)$$

Also By pythagoras theorem

$$AC^2 = AB^2 + BC^2$$

$$(3 + 1)^2 + (2 - 2)^2 = (x + 1)^2 + (y - 2)^2 + (x - 3)^2 + (y - 2)^2$$

$$16 = x^2 + 2x + 1 + y^2 - 4y + 4 + x^2 - 6x + 9 + y^2 - 4y + 4$$

$$2x^2 + 2y^2 - 4x - 8y + 18 = 16$$

$$x^2 + y^2 - 2x - 4y + 1 = 0$$

From (1) x = 1

$$\text{i.e. } 1^2 + y^2 - 2(1) - 4y + 1 = 0$$

$$y^2 - 4y = 0$$

$$y(y - 4) = 0 \Rightarrow y = 0 \text{ or } y - 4 = 0$$

$$\Rightarrow y = 0 \text{ or } y = 4$$

Hence the other vertices are (1, 0) and (1, 4).

Multiple Choice Questions

1. For each point on x-axis, y-coordinate is equal to []
a) 1 b) 2 c) 3 d) 0
2. The distance of the point (3, 4) from x - axis is []
a) 3 b) 4 c) 1 d) 7
3. The distance of the point (5, -2) from origin is []
a) $\sqrt{29}$ b) $\sqrt{21}$ c) $\sqrt{30}$ d) $\sqrt{28}$
4. The point equidistant from the points (0, 0), (2, 0), and (0, 2) is []
a) (1, 2) b) (2, 1) c) (2, 2) d) (1, 1)
5. If the distance between the points (3, a) and (4, 1) is $\sqrt{10}$, then, find the values of a []
a) 3, -1 b) 2, -2 c) 4, -2 d) 5, -3
6. If the point (x, y) is equidistant from the points (2, 1) and (1, -2), then []
a) $x + 3y = 0$ b) $3x + y = 0$ c) $x + 2y = 0$ d) $2y + 3x = 0$
7. The closed figure with vertices (-2, 0), (2, 0), (2, 2) (0, 4) and (2, -2) is a

[]

- a) Triangle b) quadrilateral c) pentagon d) hexagon

8. If the coordinates of p and Q are $(a \cos\theta, b \sin\theta)$ and $(-a \sin\theta, b \cos\theta)$. Then $OP^2 + OQ^2 =$ []

- a) $a^2 + b^2$ b) $a + b$ c) ab d) $2ab$

9. In which quadrant does the point $(-3, -3)$ lie? []

- a) I b) II c) III d) IV

10. Find the value of K if the distance between $(k, 3)$ and $(2, 3)$ is 5. []

- a) 5 b) 6 c) 7 d) 8

11. What is the condition that A, B, C are the successive points of a line? []

- a) $AB + BC = AC$ b) $BC + CA = AB$
c) $CA + AB = BC$ d) $AB + BC = 2AC$

12. The coordinates of the point, dividing the join of the point $(0, 5)$ and $(0, 4)$ in the ratio 2 : 3 internally, are []

- a) $\left(3, \frac{8}{5}\right)$ b) $\left(1, \frac{4}{5}\right)$ c) $\left(\frac{5}{2}, \frac{3}{4}\right)$ d) $\left(2, \frac{12}{5}\right)$

13. If the point $(0, 0)$, $(a, 0)$ and $(0, b)$ are collinear, then []

- a) $a = b$ b) $a + b \neq 0$ c) $ab = 0$ d) $a \neq b$

14. The coordinates of the centroid of the triangle whose vertices are $(8, -5)$,

(-4, 7) and (11, 13) []

- a) (2, 2) b) (3, 3) c) (4, 4) d) (5, 5)

15. The coordinates of vertices A, B and C of the triangle ABC are (0, -1), (2,1) and (0, 3). Find the length of the median through B. []

- a) 1 b) 2 c) 3 d) 4

16. The vertices of a triangle are (4, y), (6, 9) and (x, y). The coordinates of its centroid are (3, 6). Find the value of x and y. []

- a) -1, -5 b) 1, -5 c) 1, 5 d) -1, 5

17. If a vertex of a parallelogram is (2, 3) and the diagonals cut at (3, -2). Find the opposite vertex. []

- a) (4, -7) b) (4, 7) c) (-4, 7) d) (-4, -7)

18. Three consecutive vertices of a parallelogram are (-2, 1), (1, 0) and (4, 3). Find the fourth vertex. []

- a) (1, 4) b) (1, -2) c) (-1, 2) d) (-1, -2)

19. If the points (1, 2), (-1, x) and (2, 3) are collinear then the value of x is []

- a) 2 b) 0 c) -1 d) 1

20. If the points (a, 0), (0, b) and (1, 1) are collinear then $\frac{1}{a} + \frac{1}{b} =$ []

- a) 0 b) 1 c) 2 d) -1

Key:

1) d; 2) b; 3) a; 4) d; 5) c; 6) a; 7) c; 8) a; 9) c; 10) c;

11) a; 12) a; 13) c; 14) d; 15) b; 16) a; 17) a; 18) a; 19) b; 20) b;

Fill in the Blanks

1. The coordinates of the point of intersection of x – axis and y – axis are _____.
2. For each point on y–axis, x– coordinate is equal to _____.
3. The distance of the point (3, 4) from y –axis is _____.
4. The distance between the points (0, 3) and (–2, 0) is _____.
5. The opposite vertices of a square are (5, 4) and (–3, 2). The length of its diagonal is _____.
6. The distance between the points $(a \cos\theta + b \sin\theta, 0)$ and $(0, a \sin\theta - b \cos\theta)$ is _____.
7. The coordinates of the centroid of the triangle with vertices (0, 0) (3a, 0) and (0, 3b) are _____.
8. If OPQR is a rectangle where O is the origin and p (3, 0) and R (0, 4), Then the Coordinates of Q are _____.
9. If the centroid of the triangle (a, b), (b, c) and (c, a) is O (0, 0), then the value of $a^3 + b^3 + c^3$ is _____.
10. If (–2, –1), (a, 0), (4, b) and (1, 2) are the vertices of a parallelogram, then the values of a and b are _____.
11. The area of the triangle whose vertices are (0, 0), (a, 0) and (o, b) is _____.
12. One end of a line is (4, 0) and its middle point is (4, 1), then the coordinates of the other end _____.
13. The distance of the mid–point of the line segment joining the points (6, 8) and (2, 4) from the point (1, 2) is _____.
14. The area of the triangle formed by the points (0, 0), (3, 0) and (0, 4) is _____.

15. The co-ordinates of the mid-point of the line segment joining the points (x_1, y_1) and (x_2, y_2) are _____.
16. The distance between the points $(a \cos 25^\circ, 0)$ and $(0, a \cos 65^\circ)$ is _____.
17. The line segment joining points $(-3, -4)$ and $(1, -2)$ is divided by y-axis in the ratio _____.
18. If A $(5, 3)$, B $(11, -5)$ and p $(12, y)$ are the vertices of a right triangle right angled at p, Then $y =$ _____.
19. The perimeter of the triangle formed by the points $(0, 0)$, $(1, 0)$ and $(0, 1)$ is _____.
20. The coordinates of the circumcenter of the triangle formed by the points O $(0, 0)$, A $(a, 0)$ and B $(0, b)$ is _____.

Key:

- 1) $(0, 0)$; 2) 0; 3) 3; 4) $\sqrt{13}$; 5) 10; 6) $\sqrt{a^2 + b^2}$; 7) (a, b) ;
- 8) $(3, 4)$; 9) $3abc$; 10) $a = 1, b = 3$; 11) $\frac{1}{2}ab$; 12) $(4, 2)$
- 13) 5; 14) 6; 15) $\left(\frac{x_1 + x_2}{2}, \frac{y_1 + y_2}{2}\right)$; 16) a; 17) 3 : 1;
- 18) 2 or -4; 19) $2 + \sqrt{2}$; 20) $\left(\frac{a}{2}, \frac{b}{2}\right)$;